



■ SUSAN FRIEDRICH ARCHITECT INC.

643 ST. CLAIR AVENUE WEST, TORONTO, ONTARIO M6C 1A7  
t:(416) 588-3740 f:(416) 588-2401 e:sfarch@interlog.com



Durham District School Board  
400 Taunton Rd. E  
Whitby, Ontario. L1R 2K6

---

Project Manual for  
BIDDING AND CONTRACTING REQUIREMENTS  
**Stephen G. Saywell P.S.**  
855 Roundelay Dr.  
Oshawa, Ontario. L1J 7V1

---

*Contractors shall carefully examine and study all of the Contract Documents and shall visit the site(s) of proposed work in order to satisfy themselves by examination as to all conditions and dimensions.*

**Project No. 24 - 50**  
**Tender No. T25-10**

Issued for Permit and Tender  
January 31, 2025 ■

1 General

1.1 OWNER

.1 Owner for the Project is:

DURHAM DISTRICT SCHOOL BOARD  
400 Taunton Rd. E.  
Whitby, Ontario L1R 2K6

1.2 CONSULTANTS

.1 The following firms comprise the Consultant team for the Project:

- .1 Architect (A)  
***Susan Friedrich Architect Inc.***  
643 St Clair Avenue West  
Toronto, Ontario M6C 1A7  
Telephone:(416) 588 3740
- .2 Structural Engineer (S)  
***Lea Consulting Ltd.***  
40 University Ave., Suite 503  
Toronto, Ontario, M5J 1T1  
Telephone:(905) 470 0015
- .3 Mechanical Engineer (M) and Electrical Engineer (E)  
***CIMA+***  
415 Baseline Road West, 2<sup>nd</sup> Fl.  
Bowmanville, Ontario, L1C 5M5  
Telephone:(905) 697 4464

END OF DOCUMENT

## LIST OF CONTACTS

### GENERAL

Owner: Durham District School Board

telephone: T (905) 666-6931  
email: [richard.racioppa@ddsb.ca](mailto:richard.racioppa@ddsb.ca)

Contact: Rick Racioppa, Major Projects Supervisor Facilities Services

### ARCHITECTURAL AND GENERAL

Architect: Susan Friedrich Architect Inc.

telephone: (416) 588-3740  
fax: (416) 588-2401  
email: [info@sfarch.ca](mailto:info@sfarch.ca)

Contact: Susan Friedrich, BES, Barch, OAA

### STRUCTURAL

Structural: Lea Consulting Ltd.  
telephone: (905) 470-0015  
fax: (905) 470-0030  
email: [IBregasi@lea.ca](mailto:IBregasi@lea.ca)

Contact: Igli Bregasi, P. Eng, M. Eng,

### MECHANICAL AND ELECTRICAL

Mechanical Engineers: CIMA+

telephone: (905) 697-4464  
email: [Brad.Timson@cima.ca](mailto:Brad.Timson@cima.ca)

Contact: Brad Timson, P. Eng.

Electrical Engineers: CIMA+

telephone: (905) 697-4464  
fax: (905) 940 21 39  
email: [Luigi.Conforti@cima.ca](mailto:Luigi.Conforti@cima.ca)

Contact: Luigi Conforti, P. Eng.

## **Document 00 - Introductory Information**

00 01 03	Project Directory
00 01 05	List of Contacts
00 01 10	Table of Contents
00 01 15	List of Drawings

## **SCHEDULES**

Hardware Schedule  
Room Finish Abbreviations and General Finish Notes

## **REPORTS**

Hazardous Materials Report

## **SPECIFICATIONS GROUP**

### **GENERAL REQUIREMENTS SUBGROUP**

#### **Division 01 - General Requirements**

01 11 00	Summary of Work
01 21 00	Allowances
01 31 00	Project Coordination
01 31 19	Project Meetings
01 32 00	Project Progress Documentation
01 33 00	Submittals
01 35 13	Site Safety for Occupied Buildings
01 40 00	Quality Requirements
01 41 00	Regulatory Requirements
01 50 00	Temporary Controls and Facilities
01 60 00	Product Requirements
01 70 00	Contract Closeout
01 73 29	Cutting and Patching
01 74 00	Cleaning
01 78 23	Operation and Maintenance Manuals
01 78 36	Warranties
01 78 39	Record Documents
01 79 00	Demonstration & Training
01 91 13	General Commissioning Requirements

#### **Division 02 – Existing Conditions**

02 40 00	Demolition and Removals
----------	-------------------------

#### **Division 04 - Masonry**

04 05 00	Common Work Results for Masonry
04 05 10	Masonry Mortaring and Grouting
04 05 19	Masonry Anchorage and Reinforcing
04 05 23	Masonry Accessories
04 22 00	Concrete Unit Masonry

#### **Division 05 - Metals**

05 40 00	Cold-Formed Metal Framing
05 50 00	Metal Fabrications

**Division 06 - Wood, Plastics and Composites**

- 06 10 00 Rough Carpentry
- 06 16 43 Gypsum Sheathing
- 06 20 00 Finish Carpentry

**Division 07 - Thermal and Moisture Protection**

- 07 84 00 Firestopping
- 07 92 00 Joint Sealants

**Division 08 - Openings**

- 08 12 13 Hollow Metal Frames
- 08 13 13 Hollow Metal Doors
- 08 31 00 Access Doors and Panels
- 08 71 00 Door Hardware

**Division 09 - Finishes**

- 09 21 16 Gypsum Board Assemblies
- 09 30 00 Tiling
- 09 51 23 Acoustical Tile Ceilings
- 09 65 13 Resilient Base and Accessories
- 09 65 19 Resilient Tile Flooring
- 09 81 00 Acoustic Insulation
- 09 90 00 Painting and Coating

**Division 10 - Specialties**

- 10 11 00 Visual Display Surfaces
- 10 28 13 Washroom Accessories

**Mechanical and Electrical Specifications**

END OF TABLE OF CONTENTS

## **ARCHITECTURAL**

A001 TITLE PAGE  
A002 LEGEND AND GENERAL NOTES  
A003 OBC DATA MATRIX  
A004 EXISTING PROJECT PHOTOS  
A101 EXISTING SITE PLAN  
A102 EXISTING FLOOR KEY PLANS  
A201 PART FLOOR PLANS - DEMOLITION  
A301 PART FLOOR PLANS AND RCP  
A401 INTERIOR ELEVATIONS  
A402 INTERIOR ELEVATIONS  
A403 INTERIOR ELEVATIONS  
A501 SCHEDULES  
A502 DETAILS

## **STRUCTURAL**

S-01 STRUCTURAL DRAWINGS

## **MECHANICAL**

P-001 PLUMBING LEGEND AND NOTES  
PD-101 GROUND FLOOR AND 2<sup>ND</sup> FLOOR WASHROOM 216 & 217 DEMO PLUMBING LAYOUT  
P-101 GROUND FLOOR AND 2<sup>ND</sup> FLOOR NEW WASHROOMS 216A TO 216G NEW PLUMBING LAYOUT  
M-001 HVAC LEGENDS, NOTES, SCHEDULES AND CONTROLS  
MD-101 GROUND FLOOR AND 2<sup>ND</sup> FLOOR WASHROOMS 216 & 217 DEMO HVAC LAYOUT  
M-101 2<sup>ND</sup> FLOOR NEW WASHROOMS 216A TO 216G NEW HVAC LAYOUT  
M501 DETAILS

## **ELECTRICAL**

E-001 LEGENDS AND NOTES  
ED-101 2<sup>ND</sup> FLOOR WASHROOMS 216 & 217 DEMO LIGHTING LAYOUT  
E-101 2<sup>ND</sup> FLOOR NEW WASHROOMS 216A TO 216G NEW LAYOUT  
E-601 PANEL SCHEDULE & DETAILS

# SCHEDULES

## ROOM FINISH SCHEDULE

TO BE READ IN CONJUNCTION WITH ROOM FINISH SCHEDULE ON DRAWINGS AND ALL PLANS, ELEVATIONS, DETAIL DRAWINGS, ETC.

### List of Abbreviations and Materials:

<b>ACT</b>	Acoustic Ceiling Tile (24" x 48" existing)
<b>ARF</b>	Athletic Resilient Flooring
<b>CA</b>	Clear Anodized
<b>Cab</b>	Cabinet / Millwork
<b>CB</b>	Chalkboard
<b>Conc</b>	Concrete
<b>CMU</b>	Concrete Block
<b>C-Board</b>	Cement Board
<b>CP</b>	Control Panel
<b>Cpt</b>	Carpet
<b>CT</b>	Ceramic Tile
<b>GI</b>	Glass
<b>GB</b>	Gypsum Board
<b>GWG</b>	Georgian Wired Glass
<b>Met</b>	Metal
<b>Pt</b>	Paint
<b>PI</b>	Plaster
<b>P-lam</b>	Plastic Laminate
<b>R</b>	Rubber
<b>Res</b>	Resilient Sheet Flooring
<b>TB</b>	Tackboard
<b>Terr</b>	Terrazzo
<b>VCT</b>	Vinyl Composition Tile
<b>WB</b>	White Board
<b>Wd</b>	Wood
<b>WP</b>	Waterproofing

### GENERAL FINISH NOTES:

- a) Walls shown painted shall be properly prepared including removal of existing wall coverings, adhesives, paneling, etc. unless finishes noted to be retained.
- b) Make good all existing finishes where new work joins.
- c) All existing and new walls and previously painted finishes to be re-painted.
- d) Remove all metal grilles, to be cleaned and re-painted for re-use where indicated.
- e) All heating units, recessed convectors, grilles, pipes, access panels, hangers and miscellaneous exposed metal work (other than stainless steel, anodized aluminum and baked enamel) to be painted to match the surfaces on which they occur, unless otherwise directed by Architect.
- f) All exposed structural steel and mechanical ducts in finished areas to be painted.
- g) Existing floor finishes to be removed. Make good subfloor to receive new finishes.
- h) All hollow metal door frames, guard rails, and nosing of steel stairs shall be epoxy painted.
- i) All masonry and drywall shall be extended to u/s steel deck to provide fire rated separations as noted on drawings.  
Where walls run parallel and under OWSJ, the OWSJ shall be enclosed both sides with gypsum board to provide rated separations and sound barrier between rooms.
- j) All exposed concrete floor surfaces finished with sealer.
- k) All exposed concrete block corners shall be bull nose block.



# HARDWARE SCHEDULE

**Rivett Architectural Hardware Ltd.**

**Door Listing**

**STEPHEN G. SAYWELL - WR RENO. - 855 ROUNDELAY DR, OSHAWA, ON**

**Schedule 200733**

**Date Jan 20/25**

<b>Door Number</b>	<b>Set Number</b>
216A	1
216B	2
216C	1
216D	1
216E	1
216F	2
216G	1

Rivett Architectural Hardware Ltd.

Hardware Schedule

STEPHEN G. SAYWELL - WR RENO. - 855 ROUNDELAY DR, OSHAWA, ON

Schedule 200733
Date Jan 20/25

Set # 1

- 1 SGLE. DR. # 216A CORRIDOR 217 TO NEW WASHROOM 216A LH
1 SGLE. DR. # 216C CORRIDOR 217 TO NEW WASHROOM 216C LH
1 SGLE. DR. # 216D CORRIDOR 217 TO NEW WASHROOM 216D LH
1 SGLE. DR. # 216E CORRIDOR 217 TO NEW WASHROOM 216E LH
1 SGLE. DR. # 216G CORRIDOR 217 TO NEW WASHROOM 216G RH

5 -864 x 2150 x 45 x PSF x HMD x 45 MIN RATED

Qty

- : : 5 EA HINGE BB1168-114 X 101- 626
: : 5 EA PRIVACY C/W INDICATOR L9044 X 03B X OS-OCC X 626
: : 5 EA CLOSER 4040XP X 689
: : 5 EA KICKPLATE 190S X 203 X 813 X 630
: : 5 EA WALL STOP 232W X 626
: : 5 EA SWEEP W24S X 3'-0" X 628

Set # 2

- 1 SGLE. DR. # 216B CORRIDOR 217 TO NEW B/F WASHROOM 216B LH
1 SGLE. DR. # 216F CORRIDOR 217 TO NEW B/F WASHROOM 216F RH

2 -965 x 2150 x 45 x PSF x HMD x 45 MIN RATED

Qty

- : : 6 EA HINGE BB1168-114 X 101-NRP-626
: : 2 EA STOREROOM LOCK L9080P X 03B X 626
: : 2 EA DOOR OPERATOR SW200i X SINGLE HSG X 628
: : 2 EA DOOR OPERATOR ADD ON SW200i ADD FOR INSWING ARM
: : 2 EA OCCUPIED & EMERGENCY KIT SURF #OCC-2-EMR-S ILL KIT
: : 2 EA ELECTRIC STRIKE 1600CLB X 630
: : 2 EA KICKPLATE 190S X 203 X 914 X 630
: : 2 EA WALL STOP 232W X 626
: : 2 EA SWEEP W24S X 4'-0" X 628
: : 2 EA SIGNAGE SUPPLIED BY OTHERS
: : 2 EA V-1072A-ST/V-1072B-ST INTERCOM SUPPLIED BY OTHERS

INTERCOM TIED TO THE OFFICE

OCC-2-EMR-S KIT INCLUDES

2 EA BUTTON CM45/4 X 630

2 EA ILLUMINATED BOX CM-54GR

2 EA SIGN CM-54/SE1

CONTROLLER CX-33

1 EA ASSISTANCE REQUESTED CM-AF501SO

(RECESSED BOX BY OTHERS)

1 EA POWER CONTROLER CX-PS13 V3

3 SURFACE BOXES CM-34BL

1 EA PUSH TO LOCK BUTTON CM45/8 X 630

1 EA SURFACE BOX CM-43CBL

1 EA DOOR CONTACT CX-MDC

1 EA CM-AF540SO PUSH FOR EMERGENCY BUTTON/ANNUNCIATOR

(RECESSED BOX BY OTHERS)

1 EA TRANSFORMER 24VAC

1 EA SIGN CM-SE21A

MAIN 110V POWER SUPPLY & LOW VOLTAGE WIRING & MOUNTING BOXES FOR ASSOCIATED ACTUATORS & ACCESSORIES TO BE DONE BY ELECTRICAL DIVISION.

INSTALLATION OF POWER OPERATOR AND ASSOCIATED ELECTRONIC ACCESSORIES TO BE DONE BY HARDWARE SUPPLIER.

# RIVETT ARCHITECTURAL HARDWARE LTD.

## B/F WASHROOM DOOR C/W AUTOMATIC OPERATOR & #OCC2 EMR-S-ILL KIT

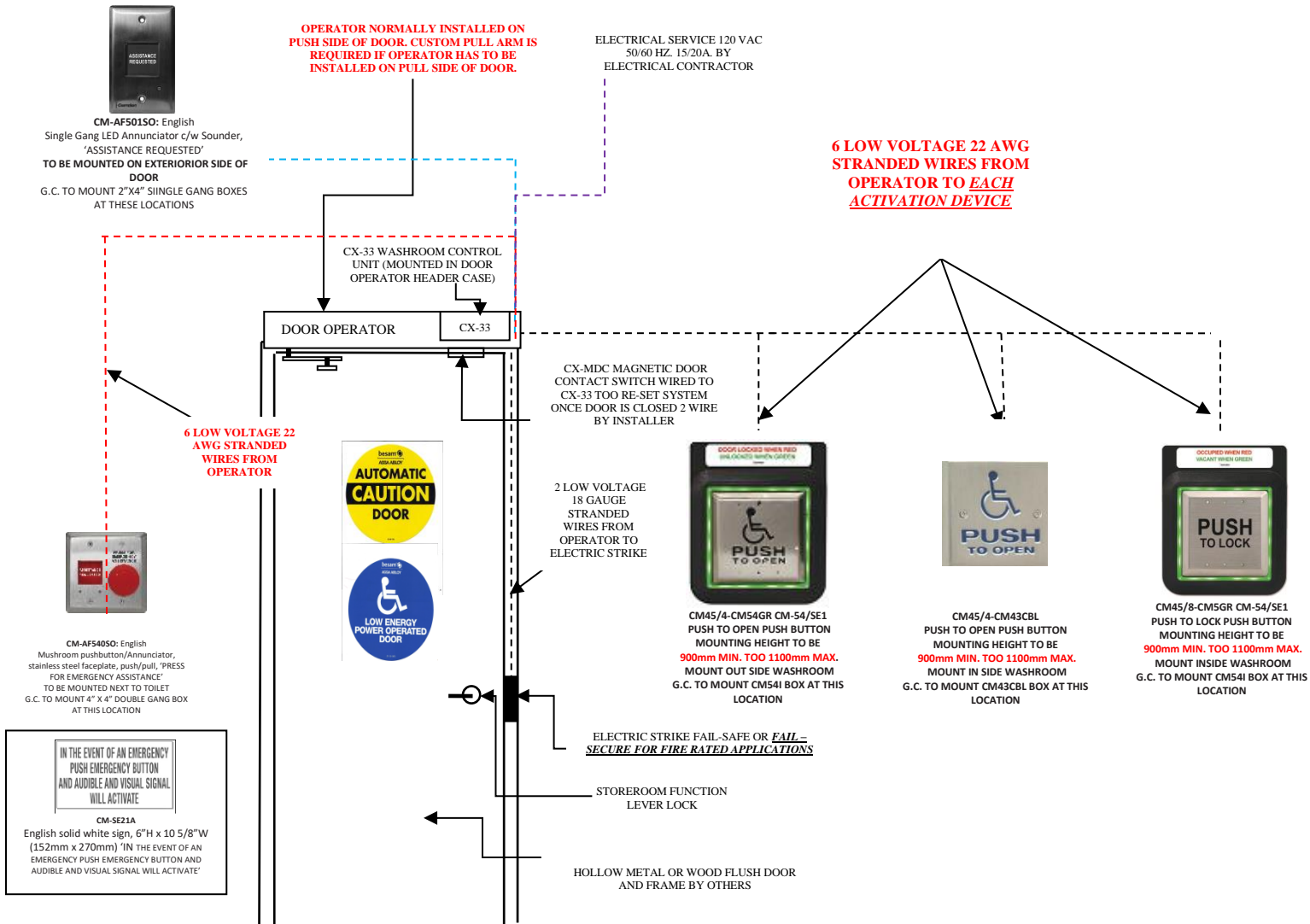

### EXPLANATION OF USE:

#### B/FREE OPERATION

1. TO OPEN DOOR ACTIVATE THE DOOR BY THE EXTERIOR HANDICAPPED PUSHPLATE AND THE DOOR WILL SLOWLY POWER OPEN, TIME OUT AND SLOWLY CLOSE.
2. TO LOCK DOOR FOR PRIVACY ACTIVATE PUSH TO LOCK SWITCH. POWER WILL BE CUT TO EXTERIOR HANDICAPPED PUSH PLATE CREATING PRIVACY.
3. ALSO ON ACTIVATION OF THE INTERIOR PUSH TO LOCK SWITCH THE EXTERIOR LIGHTED BUTTON & SIGN WILL LITE UP.
4. TO EXIT WASHROOM ACTIVATE INTERIOR HANDICAPPED PUSHPLATE AND THE DOOR WILL SLOWLY OPEN.

#### MANUAL NON B/FREE OPERATION

5. IN A **NON FIRE RATED** APPLICATION, IF THE WASHROOM IS VACANT THE DOOR CAN BE MANUALLY PUSHED OPEN AS THE ELECTRIC STRIKE WILL NOT BE ENGAGGED.
6. IN A **FIRE RATED** APPLICATION A KEY WILL BE REQUIRED TO OPERATE THE DOOR MANUALLY THE KEY WILL UNLOCK THE STOREROOM FUNCTION LOCKSET AS THE ELECTRIC STRIKE MUST BE ENGAGED TO MEET THE FIRE CODE REQUIERMENT FOR SELF LATCHING. OR EXTERIOR ACTUATOR WILL OPEN DOOR WHEN NOT OCCUPIED.

#### EMERGENCY CALL SYSTEM

IN THE EVENT OF AN EMERGENCY, ACTIVATING THE "PRESS FOR EMERGENCY ASSISTANCE" BUTTON WILL RELEASE THE ELECTRIC STRIKE AND WILL ACTIVATE SOUNDERS AND ILLUMINATE SIGNS.

#### NOTES:

1. THIS WIRING SCHEMATIC DIAGRAM IS APPLICABLE TO BESAM POWERSWING OR SW200i DOOR OPERATORS ONLY. COORDINATE WITH RIVETT ARCHITECTURAL HARDWARE FOR WIRING DETAILS.
2. DOOR OPERATOR SYSTEM SHALL BE SUPPLIED AND INSTALLED BY RIVETT ARCHITECTURAL HARDWARE LTD.
3. 120VAC WIRING TO DOOR OPERATOR HEADER AND LOW VOLTAGE WIRING WITH ELECTRICAL BOXES FOR SWITCHES WILL BE BY ELECTRICAL CONTRACTOR

**PULL SIDE BUTTONS  
NO CLOSER THAN  
600 mm – 23 1/2"  
BEYOND DOOR SWING**

**REQUIRES 3 SINGLE GANG BOX INTERIOR  
REQUIRES 1 DOUBLE GANG BOX INTERIOR  
REQUIRES 2 SINGLE GANG BOX EXTERIOR**

# RIVETT ARCHITECTURAL HARDWARE LTD.

## STANDARD WIRE LOCATIONS FOR DOOR OPERATORS

*SUPPLY VOLTAGE & LOW VOLTAGE CONTROL WIRES TO EXIT AT STRIKE SIDE OF FRAME, OR AT 36" FROM HINGE EDGE OF DOOR ON DOUBLE DOOR APPLICATION. LEAVE SUFFICIENT WIRE TO REACH TO OPPOSITE SIDE OF DOOR.*

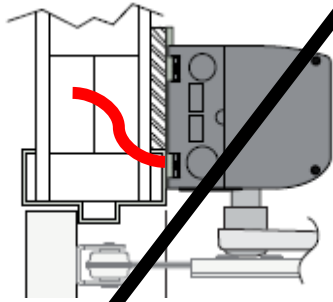
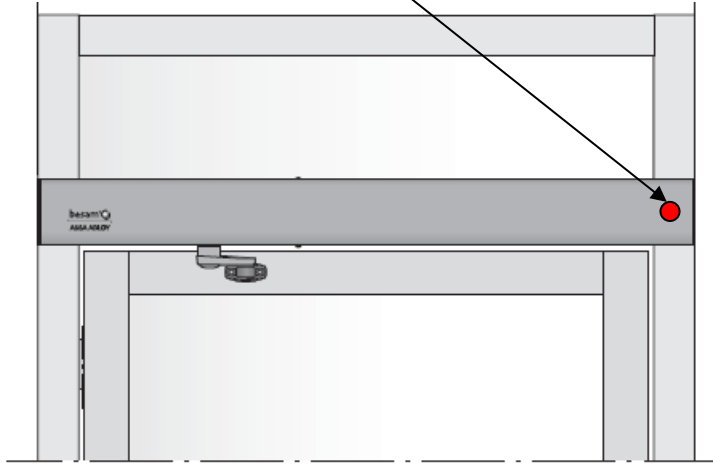

**STANDARD PUSH SIDE MOUNTED OPERATOR**

WIRES TO EXIT THROUGH FRAME AT STRIKE OF THE FRAME AS SHOWN  
IF IT IS A DOUBLE DOOR APPLICATION THEN WIRES TO EXIT 36" FROM HINGE EDGE OF DOOR.

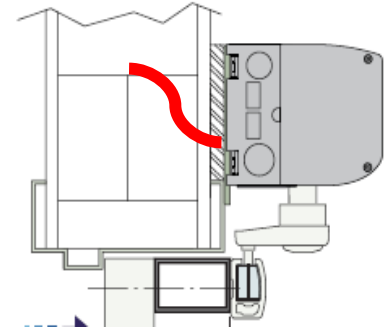

**CUSTOM PULL SIDE MOUNTED OPERATOR**

WIRES TO EXIT BETWEEN 1" & 3" ABOVE FRAME AT STRIKE SIDE OF THE FRAME AS SHOWN.  
IF IT IS A DOUBLE DOOR APPLICATION THEN WIRES TO EXIT 36" FROM HINGE EDGE OF DOOR.

# **LIMITED DESIGNATED SUBSTANCE** **SURVEY REPORT**

**LIMITED DESIGNATED SUBSTANCE SURVEY  
REPORT  
(2<sup>ND</sup> Floor Washroom Renovation)**



**Stephen G. Saywell Public School  
855 Roundelay Drive  
Oshawa, Ontario**

**Presented to:**  
Durham District School Board  
400 Taunton Road East  
Whitby, Ontario  
L1R 2K6

Attention: Richard Racioppa

**November 25, 2024**

**Maple Project No. 22211**

## EXECUTIVE SUMMARY

Maple Environmental Inc. ('Maple') was retained by Durham District School Board to perform a survey for Designated Substances as well as polychlorinated biphenyls (PCBs) and mould within Stephen G. Saywell Public School located at 855 Roundelay Drive, Oshawa Ontario (the 'Site'). It is our understanding that the building requires a survey to identify possible hazardous building materials that may be disturbed during the renovations of the selected washroom areas.

The survey was limited to the Second Floor Washrooms based on the drawings prepared by DDSB.

The findings of the current survey are summarized below. Please refer to the main body of this report for details on all materials.

### Asbestos

No asbestos-containing materials (ACM's) were identified within the surveyed area at the time of the assessment.

It should be noted that due to the presence of solid walls and ceilings (i.e. cinder block walls and above solid ceilings) throughout the survey area, access for viewing within the wall and ceiling cavities was not always possible. Suspect asbestos-containing materials may be present within wall and ceiling cavities that were not identified but are suspected to be present in this report. Caution should be taken when demolishing solid walls and ceilings within the areas being surveyed.

### Lead

Based on the Laboratory Analysis Report for lead samples and visual confirmation observation made during the fieldwork:

- Samples collected of the predominant paint colours indicated that the painted surfaces are considered to be "Low-Level Lead".
- It should be noted that lead may also be present in wiring connectors, electric cable sheathing, solder joints on copper piping, ceramic glazes, lead sheeting, masonry mortar, and as sub-surface layers to the most recent paint layers currently applied, where present at the Site.

### Mercury

- Mercury vapour is present in all fluorescent light tubes. Liquid mercury is also present in thermostatic switches located within the surveyed area.

### Silica

- Free crystalline silica, present as common construction sand, is present in all concrete and masonry products where present within the surveyed areas.

### Mould

- No visible mould growth was observed to be present within the surveyed area at the time of the assessment.
- It is possible that mould growth is present in concealed areas such as wall or ceiling cavities, pipe chases, etc. or in areas not currently assessed by Maple. The client should notify Maple should any water damage or suspect mould growth be discovered.



## PCBs

- No lights that contained ballast were observed to be present on site.
- All transformers observed on site were new and not suspected to contain PCBs.

## Recommendations

Based on the Laboratory Analytical Results and observations made on Site, Maple provides the following recommendations:

- "Low-Level Lead" paint finishes (0.1% or less) are considered virtually safe provided that:
  - Airborne lead concentrations are kept below 0.05 mg/m<sup>3</sup>;
  - General dust suppression and worker hygiene procedures are utilized; and
  - Torching or other activities that create fumes are not completed.
- Remove all mercury containing components (including fluorescent light tubes) prior to renovations if the materials are being removed. These components should be removed intact and disposed of appropriately.
- Proper dust suppression techniques and other safety precautions to control possible generation of silica dust from the demolition of concrete and masonry products present in the surveyed area should follow those outlined in the Ministry of Labour Guideline- Silica on Construction Projects, 2004.

Appropriate procedures for lead, mercury, silica, mould and PCBs must be observed if these materials are likely to be disturbed by scheduled renovations. Please refer to Section 5.0 of the report to review the required procedures.

Consideration should be given to assessing other areas of the building that could be associated with the current project, including travel path, mechanical or electrical ties in the areas outside of the immediate project area, and penetrations through the slab impacting floors below or above.

**TABLE OF CONTENTS**

<b>1.0</b>	<b>INTRODUCTION .....</b>	<b>1</b>
<b>2.0</b>	<b>APPLICABLE ONTARIO REGULATIONS.....</b>	<b>1</b>
<b>3.0</b>	<b>SURVEY SCOPE AND METHODOLOGY.....</b>	<b>3</b>
3.1	ASBESTOS-CONTAINING BUILDING MATERIALS (ACM) .....	3
3.2	LEAD.....	5
3.3	MERCURY .....	5
3.4	OTHER DESIGNATED SUBSTANCES.....	5
3.5	MOULD .....	5
3.6	POLYCHLORINATED BIPHENYLS.....	6
3.7	LIMITATIONS AND OMISSIONS FROM SCOPE .....	6
3.8	DRAWINGS.....	6
<b>4.0</b>	<b>INVENTORY FINDINGS .....</b>	<b>6</b>
4.1	ASBESTOS .....	7
4.2	LEAD.....	10
4.3	MERCURY .....	11
4.4	SILICA .....	11
4.5	ISOCYANATES .....	11
4.6	VINYL CHLORIDE MONOMER.....	11
4.7	BENZENE.....	11
4.8	ACRYLONITRILE .....	12
4.9	COKE OVEN EMISSIONS.....	12
4.10	ARSENIC .....	12
4.11	ETHYLENE OXIDE .....	12
4.12	MOULD .....	12
4.13	POLYCHLORINATED BIPHENYLS (PCBs).....	12
<b>5.0</b>	<b>RECOMMENDATIONS .....</b>	<b>12</b>
5.1	ASBESTOS .....	12
5.2	LEAD.....	12
5.3	MERCURY .....	12
5.4	SILICA .....	13
5.5	POLYCHLORINATED BIPHENYLS.....	13
<b>6.0</b>	<b>LIMITATIONS .....</b>	<b>13</b>
 <b><u>APPENDICES</u></b>		
<b>APPENDIX I</b>	LABORATORY ANALYSIS REPORT - ASBESTOS	
<b>APPENDIX II</b>	LABORATORY ANALYSIS REPORT - LEAD	
<b>APPENDIX III</b>	DRAWINGS	

## 1.0 INTRODUCTION

Maple Environmental Inc. ('Maple') was retained by Durham District School Board to perform a survey for Designated Substances as well as polychlorinated biphenyls (PCBs) and mould within Stephen G. Saywell Public School located at 855 Roundelay Drive, Oshawa Ontario (the 'Site'). It is our understanding that the building requires a survey to identify possible hazardous building materials that may be disturbed during the renovations of the selected washroom areas.

The survey was limited to the Second Floor Washrooms based on the drawings prepared by DDSB.

Section 30 of the Ontario Occupational Health and Safety Act requires that the following Designated Substances be included in a Designated Substance Survey:

***Asbestos***

***Lead***

***Mercury***

***Silica***

***Isocyanates***

***Vinyl Chloride Monomer***

***Benzene***

***Acrylonitrile***

***Coke Oven Emissions***

***Arsenic***

***Ethylene Oxide***

Additional detailed information with respect to asbestos was collected at the time of the survey to ensure compliance with Ontario Regulation 278/05.

The assessment was performed by Richards Rebois of Maple on November 1<sup>st</sup>, 2024.

## 2.0 APPLICABLE ONTARIO REGULATIONS

Applicable Ontario Regulations for each of the materials included in the investigation are briefly described below.

### 2.1 Designated Substances and Other Hazardous Materials

Section 30 of the Occupational Health and Safety Act requires building owners or their agents (architects, general contractors, etc.) to prepare or have prepared a Designated Substance report for specified potentially hazardous materials possibly present in a facility. The owner must ensure that a prospective constructor has received a Designated Substance report before entering into a binding contract with the contractor. The owner is liable to the contractor for damages and costs arising from unreported materials (of which the owner should reasonably have been aware), and could also be subject to orders and fines from the Ministry of Labour.

In addition to the requirements under the Occupational Health and Safety Act, Section 6 of the Ministry of Labour Regulations for Construction Projects requires the contractor, when submitting the Notice of Project form, report any Designated Substances likely to be used, handled or disturbed during the project.

The disturbance of asbestos materials on construction projects is controlled by Ministry of Labour Regulation R.R.O. 2005/278. The disposal of asbestos waste is controlled by Ministry of Environment Regulation, R.R.O. 1990/347.

There are no specific Ministry of Labour regulations for control of the other Designated Substances on construction projects. However, the Ministry of Labour actively enforces the general duty clause of the Health and Safety Act which protects workers and provides guidance on exposure monitoring, permissible exposure levels, medical monitoring, etc. for all Designated Substances.

Although Regulations exist for many of the Designated Substances, they apply to industry settings using Designated Substances in manufacturing processes, and do not apply to general property management, renovation or maintenance of buildings.

Polychlorinated Biphenyls ("PCBs") and mould were also included in the investigation, which are not specifically named as Designated Substances. No specific regulations are attached to these materials, but are generally governed by the due diligence section of the Health and Safety Act for employers to protect their workers.

## 2.2 Ontario Regulation 278/05 (Asbestos)

Ontario Regulation 278/05 applies to buildings with regards to maintenance, renovations or demolition work where asbestos-containing materials (ACM) is present and may be disturbed. The Regulation requires that a detailed asbestos inventory be performed in all buildings where friable and non-friable asbestos materials are present. The inventory must be available at the work place and must identify the type of asbestos, and location of asbestos on a room-by-room basis. The following report does not necessarily meet the requirements for an asbestos survey under Ontario Regulation 278/05.

In addition, the regulation requires all buildings where asbestos has been used as part of the building to implement an Asbestos Management Program (AMP).

## 2.3 Ontario Regulation 347

Ontario Regulation 347 applies to the transport of waste from the location of generation to a landfill site authorized to receive specific wastes. The regulation also prescribes procedures on how the specific wastes are to be handled at the landfill site.

The major requirements of the building owner and the person(s) removing the waste are to ensure that:

- The waste is appropriately packaged and labelled;
- The transport vehicle is appropriately placard; and
- The waste is to be transported as directly as possible to the landfill site once it leaves the site.

Some wastes require the owner to register a Generator (of waste) number and many wastes require classification that can restrict or even prohibit their disposal in landfill.

It is important to note that the building owner can be held responsible for the waste until the waste disposal site accepts it.

## 2.4 Ontario Regulation 362

Ontario Regulation 362, made under the Ontario Environmental Protection Act applies to the waste management and transport of PCB waste from the location of generation to a landfill site authorized to receive specific wastes. The regulation also prescribes procedures on how the specific wastes are to be handled at the landfill site.

## 3.0 SURVEY SCOPE AND METHODOLOGY

The survey was limited to the Second Floor Washrooms based on the drawings prepared by DDSB.

The methodology included the assessment for hazardous materials and how the assessment was performed is outlined below.

In order to determine the location of materials included in the assessment, the project technologist entered the room where practical (i.e. where access was possible without the demolition of walls, roof or ceilings or destruction of flooring). Representative views were made above accessible suspended ceiling systems. Cavities within solid ceiling and wall systems were accessed via existing access panels only. The inventory did not include demolition of building systems or finishes to check on possible hidden conditions.

### 3.1 Asbestos-Containing Building Materials (ACM)

The scope of the survey included all friable asbestos products and all major non-friable asbestos materials. The term friable is applied to a material that can be readily reduced to dust or powder by hand or moderate pressure. Asbestos materials that are friable have a much greater potential to release airborne asbestos fibres when disturbed.

Typical friable asbestos materials include: sprayed fireproofing or thermal insulation, textured (stippled) plaster, and thermal mechanical insulation. Typical non-friable materials include: asbestos cement (transite) products, vinyl floor tiles, asbestos textiles and gaskets. Additional materials such as ceiling tiles, drywall joint compounds and vinyl sheet flooring are classified as non-friable, but because of their ability to release dust when disturbed are considered as "potentially friable" for the purpose of this report.

Bulk samples of materials suspected to contain asbestos were collected for analysis during the survey. Specifically, a small volume of material was removed either from a damaged section of suspect material, or taken from intact material. In these latter cases, the material from which the sample was collected was sealed with tape to temporarily prevent fibre release. Samples were placed in plastic bags and sealed until receipt by an independent laboratory. To ensure quality results, the independent laboratory chosen successfully participates in an "Asbestos Proficiency Analytical Testing Program". As such, these independent laboratories are responsible for their findings.

Bulk samples were collected in accordance with regulatory sampling requirements and with sufficient frequency to obtain a general pattern of asbestos use within the building.

Due to building renovations or modifications that may have occurred in the past, the consistency of the application of asbestos materials may not be uniform throughout the entire Site. It is important to note that without sampling each individual wall, pipe section, ceiling tile etc. it is not possible to identify the asbestos content of every material present in the selected areas. For this reason, visually similar materials are considered to be homogenous with those already sampled elsewhere in the building without additional analysis.

O. Reg. 278/05 prescribes that a minimum number of samples be collected of materials suspected to contain asbestos. These minimum sampling requirements are summarized in Table 1, below.

<b>Table 1: Suspect ACM Bulk Sampling Requirements</b>		
<b>Type of Material</b>	<b>Quantity of Material Present</b>	<b>Minimum # of Bulk Samples Required</b>
Surfacing Materials (i.e. sprayed fireproofing, drywall joint compound, texture coat, and plaster)	Up to 90 sq/m (1000 sq/ft)	3
	From 90 sq/m (1000 sq/ft) to 450 sq/m (5000 sq/ft)	5
	Greater than 450 sq/m (5000 sq/ft)	7
All other potential ACM	Any	3

Excluding surfacing materials, the laboratory was instructed to cease analysis within Sample Groups of homogenous materials when one of the samples in the group is found to contain asbestos. For example, if three samples of a type of vinyl floor tile are collected (as required by O. Reg. 278/05) and submitted for analysis and the first sample is positively identified as containing asbestos, the balance of the sample group is not analysed.

EMC Scientific incorporated ("EMC"), an independent laboratory, was selected to analyse the collected bulk suspect asbestos samples. EMC successfully participates in an "Asbestos Proficiency Analytical Testing Program" and as such, is responsible for its findings. EMC followed the Code of Practice for the identification of asbestos in bulk material, as detailed in O. Reg. 278/05. Bulk samples were analysed using the Polarized Light Microscopy ("PLM") Technique with Dispersion Staining. The identification of asbestos fibre in bulk material is based on a collective set of parameters dependent on the unique shape and crystallographic properties of each fibre as viewed through the microscope. This method is useful for the qualitative identification of asbestos and the semi-quantitative determination of asbestos content in bulk materials expressed as a percent of projected area. The method identifies types of asbestos and also measures percent of asbestos as perceived by the analyst in comparison to standard area projections or trained experience.

The recommendations made as part of this report with respect to asbestos have taken into consideration: the condition and accessibility of the material, vibration, air movement, and general activities likely to occur within the vicinity of the ACM.

In each area or room inventoried, the technician recorded the quantity, condition (GOOD, FAIR, or POOR) of each suspect asbestos-containing material.

The definitions for condition and accessibility of the asbestos-containing items are as follows:

<b>GOOD</b>	Material is intact with no visible signs of damage.
<b>FAIR</b>	Material is visibly damaged but can be repaired.
<b>POOR</b>	Material is damaged beyond repair and likely needs to be removed.

Where ACM is found to be in GOOD condition and not likely to deteriorate or fall, the general recommendation would be to re-evaluate the condition of the material on an annual basis (required by O. Reg. 278/05). This recommendation can be subject to change if the material is located in a manner that persons untrained in asbestos awareness could physically damage it.

Where ACM is found to be damaged (i.e. FAIR or POOR condition), a recommendation to have the material cleaned-up, repaired, removed, enclosed, or encapsulated is offered. The recommendation will also indicate which asbestos procedure should be used to perform the remedial work (i.e. Type 1, Type 2, Type 3, or Glove Bag Removal Methods).

### 3.2 Lead

The investigation included the collection and analysis of all major paint colour applications for the presence of lead in the paint. Other materials that possibly contain lead were identified by known historic use, where relevant. The lead in paint samples were analysed by EMSL, using atomic absorption spectrophotometry. EMSL is AIHA (American Industrial Hygiene Association) and NIOSH (National Institute of Occupational Safety and Health) accredited for this type of analysis. The Laboratory Analysis Report for lead in paint samples is included with this Report as Appendix II.

### 3.3 Mercury

The assessment included a visual identification of fluorescent light tubes, switches, electrical controls, heating system thermostats, thermometers, and other components historically known to contain mercury.

### 3.4 Other Designated Substances

Other materials listed in Section 1.0 of this Report were identified on a visual basis where present, as part of the current assessment. It should be noted that no manufacturing or heavy industrial activities are known by Maple to occur at the Site. Therefore, Designated Substances associated with these activities (i.e. those other than Asbestos, Lead, Mercury, and Silica) would not be expected to be present in the selected areas.

### 3.5 Mould

The assessment for mould was conducted in accordance with standard industry practice as set out in the Canadian Construction Association (CCA) "Mould Guidelines for the Canadian Construction Industry" for a visual assessment. Although there are no regulatory requirements in Ontario for such an assessment, the CCA Guidelines, and similar guidelines from other agencies have been accepted as the industry standard by most experts, consultants, the Ontario Ministry of Labour, and the Canadian Construction Association.

All guidelines and protocols for mould investigations indicate that investigations should be performed largely on a visual basis with limited collection of bulk and/or air samples. The Ontario Ministry of Labour has consistently enforced the removal of all mould from buildings regardless of mould genus or species, and therefore bulk samples or air samples for confirmation of mould are not typically collected for investigative purposes where mould is visible.

### 3.6 Polychlorinated Biphenyls

Manufacturers labels/codes collected from fluorescent lamp ballasts suspected of containing Polychlorinated Biphenyls ("PCBs") are compared with Environment Canada's document titled "Identification of Lamp Ballasts Containing PCBs", which identifies PCB-containing ballasts.

### 3.7 Limitations and Omissions from Scope

Due to the nature of building construction some limitations exist as to the possible thoroughness of any building materials inventory. The field observations, measurements, and analysis are considered sufficient in detail and scope to form a reasonable basis for the findings presented in this report. Maple warrants that the findings and conclusions contained herein have been made in accordance with generally accepted evaluation methods in the industry and applicable regulations at the time of the performance of the inventory.

It is possible that conditions may exist which could not be reasonably identified within the scope of the inventory or which were not apparent during the Site investigation. Maple believes that the information collected during the investigation concerning the property is reliable. No other warranties are implied or expressed.

During a standard ACM inventory performed for the purposes of regulatory compliance, it is industry practice to exclude certain suspect asbestos-containing materials from sampling. These materials are often excluded from sampling due to the risk of compromising the health and safety of the technician, other building occupants, or the integrity of the systems with which these materials are associated. Examples of such materials include; elevator brakes, roofing felts and mastics, high voltage wiring, mechanical packing and gaskets, underground services or piping, fire-doors, window caulking and levelling compound. Where observed, these materials were presumed to be ACM.

### 3.8 Drawings

Drawings included in Appendix III will indicate the locations of any major applications of an asbestos-containing material with the exception of mechanical insulations, drywall, plaster finishes and transite (which cannot be accurately depicted on drawings). The information depicted on the drawings is not to scale and is only meant to provide a general representation of the locations of asbestos-containing materials.

## 4.0 INVENTORY FINDINGS

The findings of the survey are presented separately below for each of the eleven Designated Substances as well as microbial growth (mould), and polychlorinated biphenyls. Asbestos is further detailed by typical applications of asbestos.



#### 4.1 Asbestos

The following is a brief discussion of the extent to which ACM was identified in the surveyed area. The discussion is organized under the headings of materials that are generally suspected of containing asbestos. The sample numbers refer to the laboratory analysis report presented as Appendix I and summarised in Table 2 below.

Eighteen (18) bulk samples were collected for the determination of asbestos content and submitted to the lab to be analysed. Due to the presence of more than one phase of material in some of the original samples the laboratory may have performed multiple analyses for some samples. As a result, a total of twenty-five (25) samples were analyzed.

<b>Table 2: Analysis Summary of Asbestos Bulk Samples</b>			
<b>Sample No.</b>	<b>Room Name</b>	<b>Sample Description</b>	<b>Result</b>
S01A	Boy's	DJC – Fire Stop on Upper Wall in Ceiling Space	None Detected
S01B	Boy's	DJC – Fire Stop on Upper Wall in Ceiling Space	None Detected
S01C	Girl's	DJC – Fire Stop on Upper Wall in Ceiling Space	None Detected
S02A	Boy's	White Primer Masonry Sealant	None Detected
		Grey Cementitious Material	None Detected
S02B	Boy's	White Primer Masonry Sealant	None Detected
		Grey Cementitious Material	None Detected
S02C	Boy's	White Primer Masonry Sealant	None Detected
		Grey Cementitious Material	None Detected
S03A	Corridor	AT02 – 2' x 4' Acoustic Tile, Fissure and Pinhole	None Detected
S03B	Corridor	AT02 – 2' x 4' Acoustic Tile, Fissure and Pinhole	None Detected
S03C	Corridor	AT02 – 2' x 4' Acoustic Tile, Fissure and Pinhole	None Detected
S04A	Boy's	Tile Grout - Grey Cementitious Material	None Detected
		Yellow Mastic	None Detected
S04B	Boy's	Tile Grout - Grey Cementitious Material	None Detected
S04C	Boy's	Tile Grout - Grey Cementitious Material	None Detected
S05A	Boy's	Yellow Ceramic Tile Mastic	None Detected
S05B	Boy's	Yellow Ceramic Tile Mastic	None Detected
S05C	Boy's	Yellow Ceramic Tile Mastic	None Detected
S06A	Barrier Free Washroom	VFT01 – Beige 12" x 12" Vinyl Floor Tile	None Detected
		Black Mastic	None Detected
S06B	Barrier Free Washroom	VFT01 – Beige 12" x 12" Vinyl Floor Tile	None Detected
		Black Mastic	None Detected

<b>Table 2: Analysis Summary of Asbestos Bulk Samples</b>			
<b>Sample No.</b>	<b>Room Name</b>	<b>Sample Description</b>	<b>Result</b>
S06C	Barrier Free Washroom	VFT01 – Beige 12" x 12" Vinyl Floor Tile	None Detected
		Black Mastic	None Detected

No asbestos-containing materials (ACM) were present in the surveyed areas at the time of the assessment. Details for suspected asbestos-containing materials are presented below under the headings of the most typical asbestos applications in buildings.

It should be noted that due to the presence of solid walls and ceilings (i.e. cinder block walls and above solid ceilings) throughout the survey area, access for viewing within the wall and ceiling cavities was not always possible. Suspect asbestos-containing materials may be present within wall and ceiling cavities that were not identified but are suspected to be present in this report. Caution should be taken when demolishing solid walls and ceilings within the areas being surveyed.

#### 4.1.1 Sprayed Fireproofing

No sprayed fireproofing was identified within the surveyed area at the time of the assessment.

#### 4.1.2 Thermal Mechanical Insulation (Friable)

##### Piping Systems:

No asbestos-containing pipe systems were identified within the surveyed area at the time of the assessment.

Pipe systems observed within the surveyed areas were observed to be either insulated with fiberglass insulation or were not insulated.

##### Duct Systems:

Duct systems observed throughout the surveyed area were observed to be either un-insulated or were insulated with foil-face fibreglass insulation which is not suspected to contain asbestos.

##### Mechanical Equipment:

Air handling units were observed to be externally un-insulated.

#### 4.1.3 Texture Finish (Friable)

No asbestos-containing textured finishes were identified within the surveyed area at the time of the assessment.

#### 4.1.4 Acoustic Ceiling Tiles (Potentially Friable)

No asbestos-containing acoustic ceiling tile systems were identified within the surveyed area at the time of the assessment.

Two (2) visually distinct types of lay-in acoustic ceiling tile systems were observed in the surveyed areas. A brief description of each of the ceiling tiles is outlined below:

- AT-01 (2' x 4' tile with No Pattern):

AT-01 was observed to be present in the Washrooms.

No bulk samples of AT-01 were collected as a manufacture's date stamp code (01/10/14) was present on the backside of the tile indicating that the tiles were recently manufactured and therefore not suspected to contain asbestos.

- AT-02 (2' x 4' Spiral Fissures and Pinhole Pattern):

AT-02 was observed to be present in the Corridor and adjoining Offices.

Three (3) representative samples (Sample Set S03A-C) of AT02 were collected and analyzed for determination of asbestos content. Analysis of Sample Set S03 found that the samples do not contain asbestos.

#### 4.1.5 Vinyl Sheet Flooring (Potentially Friable)

No vinyl sheet flooring finishes were identified within the surveyed area at the time of the assessment.

#### 4.1.6 Vinyl Floor Tile (Non-Friable)

No asbestos-containing vinyl floor tiles were identified within the surveyed area at the time of the assessment.

One (1) visually distinct type of vinyl floor tiles was observed in the surveyed area. A brief description of the vinyl floor tile is outlined below:

- VFT01 (Beige 12" x 12" Flooring with White and Grey Fleck Pattern):

VFT01 was observed to be present in Barrier Free Washroom.

Three (3) representative samples (Sample Set S06A-C) of VFT01 were collected and analyzed for determination of asbestos content. Analysis of Sample Set S06 found that VFT01 does not contain asbestos. An associated layer of black mastic was included in the analysis and was found not to contain asbestos.

#### 4.1.7 Asbestos Cement Products "Transite" (Non-Friable)

No asbestos-cement products, commonly referred to as "Transite", were found within the surveyed areas at the time of the assessment.

#### 4.1.8 Drywall Joint Compound (DJC) (Potentially Friable)

No asbestos-containing drywall joint compound was identified within the surveyed area at the time of the assessment.

Drywall finishes were present in the form fire barriers present over openings in the walls within the ceiling space of the washrooms.

Three (3) representative samples (Sample Set S01A-C) of drywall joint compound were collected and analyzed for determination of asbestos content. Analysis of Sample Set S01 found that none of the samples contained asbestos.

#### 4.1.9 Plaster (Potentially Friable)

No plaster finishes were identified within the surveyed areas at the time of the assessment.

#### 4.1.10 Vermiculite (Friable)

No vermiculite insulation was observed to be present within the surveyed area at the time of the assessment. It should be noted that loose fill vermiculite insulation can often be present within voids of masonry and possibly some pre-manufactured surveyed area components that would not be identified during the course of this assessment.

#### 4.1.11 Other

- **Masonry Block Sealant**

White primer sealant was observed to be applied to the surface of the masonry walls in Washrooms.

Three (3) representative samples of masonry sealant were collected (Sample Set S02A-C) and analyzed for asbestos. Analysis of Sample Set S02 found that the primer samples do not contain asbestos. An associated layer of a grey cementitious material (mortar) was included in the analysis and was found not to contain asbestos.

- **Ceramic Tile Grout**

Grey cementitious material was observed to be applied to the gap of the ceramic tiles within the Washrooms.

Three (3) representative samples of grey cementitious material were collected (Sample Set S04A-C) and analyzed for asbestos. Analysis of Sample Set S04 found that the cementitious grout material does not contain asbestos. An associated layer of a yellow mastic was included in the analysis and was found not to contain asbestos.

- **Ceramic Tile Mastic**

Yellow ceramic tile mastic was observed to be applied to the tiles present in the Washrooms.

Three (3) representative samples of duct mastic were collected (Sample Set S05A-C) and analyzed for asbestos. Analysis of Sample Set S05 found that the samples do not contain asbestos.

#### 4.2 Lead

Two (2) bulk paint samples were collected for determination of lead content and submitted to ESML for analysis during the assessment. The sample number refers to the Certificate of Analysis Report presented as Appendix II and summarised in Table 3 below. Sample results are colour coded to reflect the classification of lead content as presented in Table 4 - EACC Classification of Lead.

<b>Table 3: Analysis Summary of Lead Samples</b>			
<b>Sample No.</b>	<b>Locations</b>	<b>Sample Description</b>	<b>Result (%)</b>
LBP01	Boy's	Yellow Paint on Masonry Wall	<0.0080
LBP02	Boy's	Blue Paint on Door Frame	<0.0080

No regulations currently exist in Ontario defining the lower limit of lead-containing material. The Ontario Ministry of Labour (MOL) has issued a guideline for lead abatement, entitled "Guideline – Lead on Construction Projects" (2004) which is considered enforceable. The Guideline does not specify what constitutes a material as "lead-containing". Instead, it outlines procedures based on the concentration of airborne lead encountered during removal, as well as provides procedures and/or specific operations for lead-containing material removal. However, the Environmental Abatement Council of Canada (EACC) "Lead Guideline for Construction, Renovation, Maintenance or Repair" document classifies paint as either Low-Level, Lead-Containing, or Lead-Based as outlined in Table 4 below.

<b>TABLE 4: EACC Classification of Lead Paint</b>	
<b>Concentration of Lead (%)</b>	<b>Definition</b>
0.1 or less	Low Level Lead (Virtually Safe)
Greater than 0.1 but less than 0.5	Lead-Containing
0.5 or greater	Lead-Based

Based on these criteria and the results of the sample analysis, all paint finishes samples are considered to be "Low-Level Lead" (virtually safe).

#### 4.3 Mercury

Mercury vapour is present in all fluorescent light tubes. Liquid mercury is also present in thermostatic switches located within the surveyed area.

#### 4.4 Silica

Free crystalline silica, present as common construction sand, is present in all concrete and masonry products where present in the selected areas surveyed.

#### 4.5 Isocyanates

Free isocyanate compounds would not be expected to be found in a non-manufacturing facility.

#### 4.6 Vinyl Chloride Monomer

Vinyl chloride monomer would not be expected to be found in a non-manufacturing facility.

#### 4.7 Benzene

Benzene would not be expected to be found in a non-manufacturing facility.

#### 4.8 Acrylonitrile

Acrylonitrile would not be expected to be found in a non-manufacturing facility.

#### 4.9 Coke Oven Emissions

Coke oven emissions would not be expected to be found in a non-manufacturing facility.

#### 4.10 Arsenic

Arsenic would not be expected to be found in a non-manufacturing facility.

#### 4.11 Ethylene Oxide

Ethylene oxide would not be expected to be found in a non-manufacturing facility.

#### 4.12 Mould

No mould growth was observed during the time of assessment within the surveyed area.

It is possible that mould growth is present in concealed areas such as wall or ceiling cavities, pipe chases, etc. or in areas not currently assessed by Maple. The client should notify Maple should any water damage or suspect mould growth be discovered.

#### 4.13 Polychlorinated Biphenyls (PCBs)

The fluorescent lamp fixtures observed within the surveyed areas contained T8 light tubes. T8 fixtures have electronic ballast and are considered as not containing PCB.

All transformers observed on site were new and not suspected to contain PCBs.

### 5.0 RECOMMENDATIONS

#### 5.1 Asbestos

No asbestos-containing materials (ACM's) were identified within the surveyed area at the time of the assessment and therefore no Asbestos Abatement recommendations are warranted.

#### 5.2 Lead

No paint finishes sampled were found to be lead-containing.

Low-Level Lead paints (0.1% or less) are considered to be "virtually safe" provided that:

- Airborne lead concentrations are kept below 0.05 mg/m<sup>3</sup>;
- General dust suppression and worker hygiene procedures are utilized; and
- Torching or other activities that create fumes are not completed.

#### 5.3 Mercury

Mercury vapour is present in all fluorescent light tubes. All fluorescent light tubes should be handled and disposed of appropriately.

#### 5.4 Silica

Proper dust suppression techniques and other safety precautions to control possible generation of silica dust from the demolition of concrete and masonry products present in the building should follow those outlined in the Ministry of Labour Guideline- Silica on Construction Projects, 2004.

#### 5.5 Polychlorinated Biphenyls

Prior to disposal, all fluorescent lamp ballasts should be inspected and compared with Environment Canada's document titled "Identification of Lamp Ballasts Containing PCBs" for the presence of PCB's.

### 6.0 LIMITATIONS

Due to the nature of building construction some limitations exist as to the possible thoroughness of the subject investigation. The field observations are considered sufficient in detail and scope to form a reasonable basis for the findings presented in this report. Maple warrants that the findings and conclusions contained herein have been made in accordance with generally accepted evaluation methods in the industry and applicable regulations at the time of the performance of the assessment.

It is possible that conditions may exist which could not be reasonably identified within the scope of the investigation or which were not apparent during the site investigation. Maple believes that the information collected during the investigation period concerning the property is reliable. No other warranties are implied or expressed.

Information provided by Maple is intended for Client use ONLY. Any use by a third party, of reports or documents authored by Maple, or any reliance by a third party on or decisions made by a third party based on the findings described in said documents, is the sole responsibility of such third parties. Maple accepts no responsibility for damages suffered by any third party as a result of decisions made or actions conducted.

The liability of Maple or its staff will be limited to the lesser of the fees paid or actual damages incurred by the Client. Maple will not be responsible for any consequential or indirect damages. Maple will only be liable for damages resulting from negligence of Maple; all claims by the Client shall be deemed relinquished if not made within two years after last date of services provided.

Please contact Maple Environmental Inc. at (905) 257-4408 for inquiries regarding this project.

#### **MAPLE ENVIRONMENTAL INC.** Environment, Health and Safety Consultants

Prepared By:



**Richards Reboks,**  
*Senior Project Technologist*

Reviewed By:



**Kyle Prosser**  
*Senior Project Manager*

**APPENDIX I**  
LABORATORY ANALYSIS REPORT - ASBESTOS



# Laboratory Analysis Report

To:

**Richards Reboks**  
 Maple Environmental Inc.  
 482 South Service Road East, Suite 116  
 Oakville, Ontario  
 L6J 2X6

**EMC LAB REPORT NUMBER:** A111585  
**Job/Project Name:** DDSB, Stephen G. Saywell PS  
**Analysis Method:** Polarized Light Microscopy – EPA 600  
**Date Received:** Nov 7/24      **Date Analyzed:** Nov 15/24  
**Analyst:** Chengming Li  
**Reviewed By:** Jayoda Perera

**No. of Phases Analyzed:** 25  
**Job No:** 22211  
**Number of Samples:** 18  
**Date Reported:** Nov 15/24

Client's Sample ID	Lab Sample No.	Description/Location	Sample Appearance	SAMPLE COMPONENTS (%)		
				Asbestos Fibres	Non-asbestos Fibres	Non-fibrous Material
S01A	A111585-1	DJC- Boys washroom ceiling space	Off white, joint compound	ND		100
S01B	A111585-2	DJC- Boys washroom ceiling space	Off white, joint compound	ND		100
S01C	A111585-3	DJC- Girls washroom ceiling space	Off white, joint compound	ND		100
S02A	A111585-4	Masonry sealant boys washroom	2 Phases: a) White, primer b) Grey, cementitious material	ND ND		100 100
S02B	A111585-5	Masonry sealant boys washroom	2 Phases: a) White, primer b) Grey, cementitious material	ND ND		100 100
S02C	A111585-6	Masonry sealant boys washroom	2 Phases: a) White, primer b) Grey, cementitious material	ND ND		100 100
S03A	A111585-7	ATO2- 2'x4' with fissure and pinhole	Grey, ceiling tile	ND	75	25
S03B	A111585-8	ATO2- 2'x4' with fissure and pinhole	Grey, ceiling tile	ND	75	25
S03C	A111585-9	ATO2- 2'x4' with fissure and pinhole	Grey, ceiling tile	ND	75	25
S04A	A111585-10	Ceramic tile grout- boys washroom	2 Phases: a) Grey, cementitious material b) Yellow, mastic	ND ND		100 100
S04B	A111585-11	Ceramic tile grout- boys washroom	Grey, cementitious material	ND		100

**EMC LAB REPORT NUMBER:** A111585

**Client's Job/Project Name/No.:** 22211

**Analyst:** Chengming Li

Client's Sample ID	Lab Sample No.	Description/Location	Sample Appearance	SAMPLE COMPONENTS (%)		
				Asbestos Fibres	Non-asbestos Fibres	Non-fibrous Material
S04C	A111585-12	Ceramic tile grout- boys washroom	Grey, cementitious material	ND		100
S05A	A111585-13	Ceramic tile mastic- boys washroom	Yellow, mastic	ND		100
S05B	A111585-14	Ceramic tile mastic- boys washroom	Yellow, mastic	ND		100
S05C	A111585-15	Ceramic tile mastic- boys washroom	Yellow, mastic	ND		100
S06A	A111585-16	VFT01- beige 12"x12" vinyl tile	2 Phases:			
			a) Beige, vinyl floor tile	ND		100
S06B	A111585-17	VFT01- beige 12"x12" vinyl tile	2 Phases:			
			a) Beige, vinyl floor tile	ND		100
S06C	A111585-18	VFT01- beige 12"x12" vinyl tile	2 Phases:			
			a) Beige, vinyl floor tile	ND		100
			b) Black, mastic	ND		100

**Note:**

1. Bulk samples are analyzed using Polarized Light Microscopy (PLM) and dispersion staining techniques. The analytical procedures are in accordance with EPA 600/R-93/116 method.
2. The results are only related to the samples analyzed. **ND** = None Detected (no asbestos fibres were observed), **NA** = Not Analyzed (analysis stopped due to a previous positive result).
3. This report may not be reproduced, except in full without the written approval of EMC Scientific Inc. This report may not be used by the client to claim product endorsement by NVLAP or any other agency of the U.S. Government.
4. The Ontario Regulatory Threshold for asbestos is 0.5%. The limit of quantification (LOQ) is 0.5%.
5. Vinyl floor tiles may contain very fine asbestos fibres which the PLM method cannot detect. TEM analysis may be necessary to confirm the absence of asbestos.

**APPENDIX II**  
**LABORATORY ANALYSIS REPORT – LEAD**



**EMSL Canada Inc.**

2756 Slough Street, Mississauga, ON L4T 1G3  
Phone/Fax: (289) 997-4602 / (289) 997-4607  
<http://www.EMSL.com> [torontolab@emsl.com](mailto:torontolab@emsl.com)

EMSL Canada Or 552418932  
CustomerID: 55MAPL78  
CustomerPO: 22211  
ProjectID:

Attn: **Richard Reboks**  
**Maple Environmental, Inc.**  
**482 South Service Road East**  
**Suite 116**  
**Oakville, ON L6J 2X6**

Phone: (905) 257-4408  
Fax: (905) 257-8865  
Received: 11/20/2024 10:08 AM  
Collected:

Project: 22211 DDSB, Stephen Saywell PS

**Test Report: Lead in Paint Chips by Flame AAS (SW 846 3050B/7000B)\***

<i>Client SampleDescription</i>	<i>Collected</i>	<i>Analyzed</i>	<i>Weight</i>	<i>RDL</i>	<i>Lead Concentration</i>
LBP1 552418932-0001		11/20/2024	0.2537 g	0.0080 % wt	<0.0080 % wt
	Site: Yellow Paint in Boys Washroom Wall				
LBP2 552418932-0002		11/20/2024	0.2530 g	0.0080 % wt	<0.0080 % wt
	Site: Blue Paint on Door Frame, Boys				

Rowena Fanto, Lead Supervisor  
or other approved signatory

EMSL maintains liability limited to cost of analysis. Interpretation and use of test results are the responsibility of the client. This report relates only to the samples reported above, and may not be reproduced, except in full, without written approval by EMSL. EMSL bears no responsibility for sample collection activities or analytical method limitations. The report reflects the samples as received. Results are generated from the field sampling data (sampling volumes and areas, locations, etc.) provided by the client on the Chain of Custody. Samples are within quality control criteria and met method specifications unless otherwise noted.  
\* Analysis following Lead in Paint by EMSL SOP/Determination of Environmental Lead by FLAA. Reporting limit is 0.008% wt based on the minimum sample weight per our SOP. "<" (less than) result signifies the analyte was not detected at or above the reporting limit. Measurement of uncertainty is available upon request. Definitions of modifications are available upon request.  
Samples analyzed by EMSL Canada Inc. Mississauga, ON AIHA LAP, LLC-ELLAP Accredited #196142

Initial report from 11/22/2024 08:14:06

**APPENDIX III**  
DRAWINGS

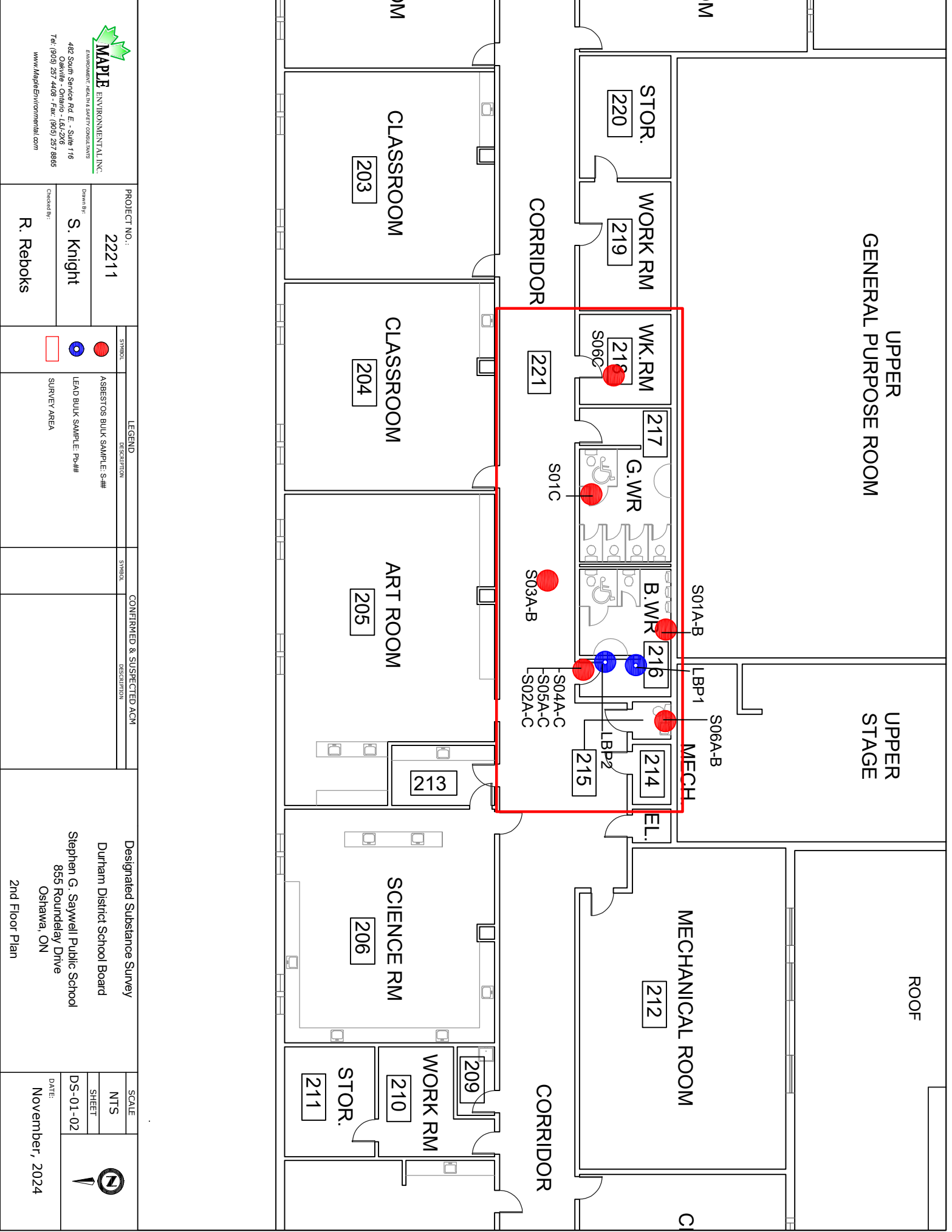

**MAPLE ENVIRONMENTAL INC.**  
 ENVIRONMENTAL HEALTH & SAFETY CONSULTANTS  
 482 South Service Rd. E., Suite 116  
 Oakville, Ontario - L6L 2X6  
 Tel: (905) 257 4408 - Fax: (905) 257 8865  
 www.MapleEnvironmental.com

PROJECT NO.:	22211
Drawn by:	S. Knight
Checked by:	R. Reboks

SYMBOL	DESCRIPTION
● (Red)	ASBESTOS BULK SAMPLE: S-##
● (Blue)	LEAD BULK SAMPLE: Pb-##
□ (Red)	SURVEY AREA

SYMBOL	DESCRIPTION
■ (Red)	CONFIRMED & SUSPECTED ACM

Designated Substance Survey  
 Durham District School Board  
 Stephen G. Sawell Public School  
 855 Roundelay Drive  
 Oshawa, ON  
 2nd Floor Plan

SCALE	NTS
SHEET	DS-01-02
DATE:	November, 2024

North Arrow

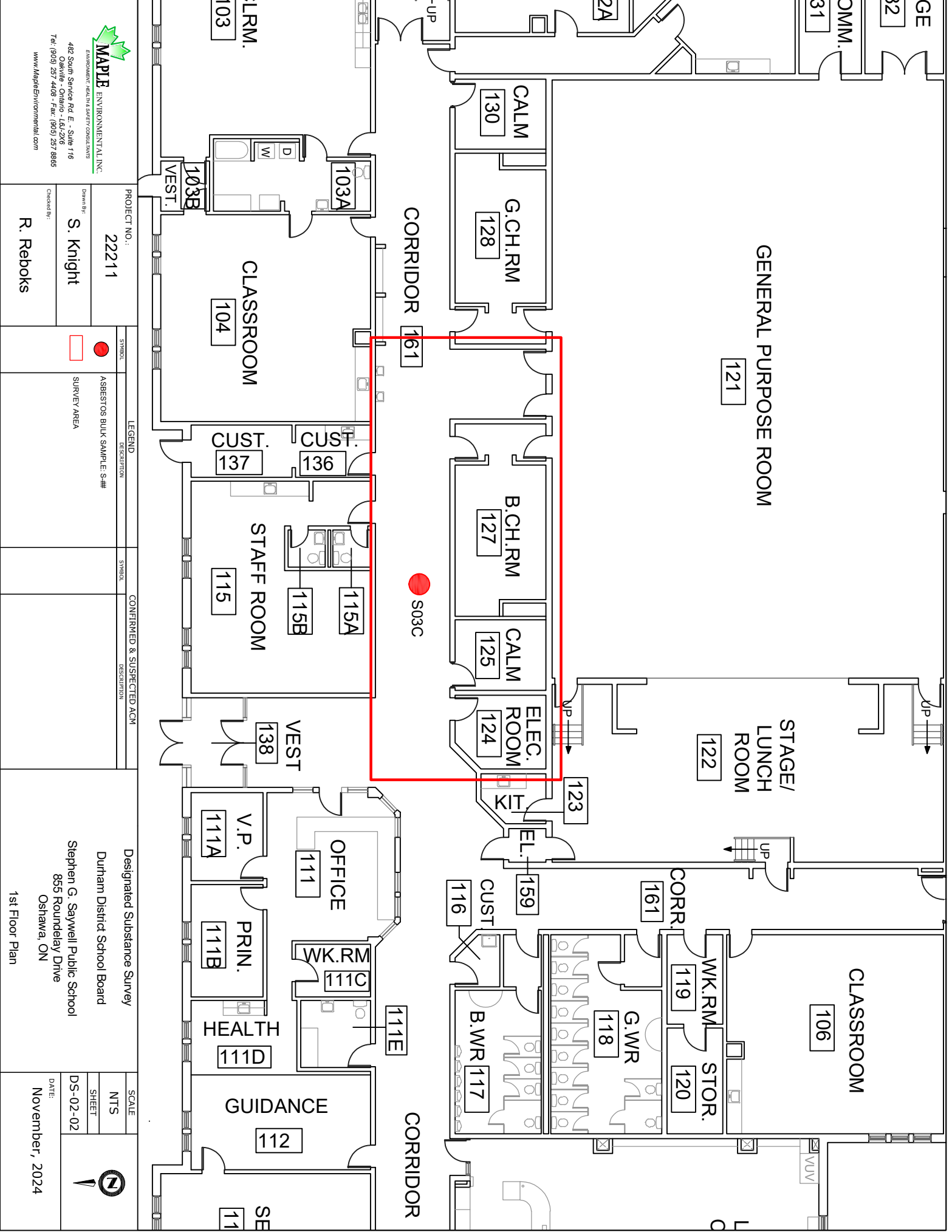

**MAPLE ENVIRONMENTAL INC.**  
 ENVIRONMENTAL HEALTH & SAFETY CONSULTANTS  
 482 South Service Rd. E., Suite 116  
 Oakville, Ontario, L6L 2X6  
 Tel: (905) 257 4408 - Fax: (905) 257 8865  
 www.MapleEnvironmental.com

PROJECT NO.:  
**22211**

Drawn by:  
**S. Knight**

Checked by:  
**R. Reboks**

SYMBOL	LEGEND	SYMBOL	DESCRIPTION
<span style="color: red;">●</span>	ASBESTOS BULK SAMPLE: S-##		CONFIRMED & SUSPECTED ACM
<span style="border: 1px solid red; display: inline-block; width: 10px; height: 10px;"></span>	SURVEY AREA		

Designated Substance Survey  
 Durham District School Board  
 Stephen G. Saywell Public School  
 855 Roundelay Drive  
 Oshawa, ON

1st Floor Plan

SCALE  
 NTS

SHEET  
 DS-02-02

DATE:  
 November, 2024

## **1 GENERAL**

- 1.1 The requirements of the Articles of Agreement, Conditions of the Contract, Division 1 apply to and form all Sections of the Contract Documents and the Work. Refer to these in conjunction with TDSB requirements.
- 1.2 Work in this Specification is divided into descriptive sections which are not intended to identify absolute contractual limits between Subcontractors, nor between the Contractor and their Subcontractors. The Contractor is responsible for organizing division of labour and supply of materials essential to complete the Contract. The Consultant assumes no liability to act as an arbiter to establish subcontract limits between Sections or Divisions of Work.
- 1.3 It is intended that Work supplied under these Contract Documents shall be complete and fully operational in every detail for the purpose required. Provide all items, articles, materials, services and incidentals, whether or not expressly specified or shown on Drawings, to make finished Work complete and fully operational, consistent with the intent of the Contract Documents.
- 1.4 Work designated as "N.I.C." is not included in this Contract.
- 1.5 Specifications, Schedules and Drawings are complementary and items mentioned or indicated on one may not be mentioned or indicated on the others.
- 1.6 Contractors finding discrepancies or ambiguities in, or omissions from the Drawings, Specifications or other Contract Documents, or having doubt as to the meaning and intent of any part thereof shall contact the Consultant for clarification. If the Consultant is not contacted for clarification, execute the Work in accordance with the most stringent requirements.
- 1.7 Mention in the specifications or indication on the drawings of materials, Products, operations, or methods, requires that the Contractor provide each item mentioned or indicated of the quality or subject to the qualifications noted; perform according to the conditions stated in each operation prescribed; and provide labour, materials, Products, equipment and services to complete the Work.
- 1.8 Where the singular or masculine is used in the Contract Documents, it shall be read and construed as if the plural, feminine or neuter had been used when the context or the statement so requires and as required to complete the Work, and the rest of the sentence, clause, paragraph, or Article shall be construed as if all changes in grammar, gender or terminology thereby rendered necessary had been made.
- 1.9 The terms "approved", "review", "reviewed", "accepted", "acceptance", "acceptable", "satisfactory", "selected", "directed", "instructed", "required", "submit", "permitted" or similar words or phrases are used in standards or elsewhere in Contract Documents, it shall be understood, that words "by (to) the Consultant" follow, unless context provides otherwise.



1.10 Where the words 'submit', 'acceptable' and 'satisfactory' are used in the Contract Documents, they shall be considered to be followed by the words 'to the Consultant' unless the context provides otherwise.

1.11 The terms “exposed” or “exposed to view” refers to surfaces that are within the line of vision of persons from any accessible viewpoint, both within and without the building. Where any part of a surface is exposed to view, all other portions of that surface shall also be considered as exposed to view.

1.12 Refer to DDSB General Requirements and shall take precedence in the case of any discrepancies.

## **2 PROGRESS AND COMPLETION**

2.1 Refer to TDSB requirements and documents for Progress and Completion dates.

## **3 EXISTING SITE CONDITIONS**

3.1 Make a careful examination of the site, and investigate and be satisfied as to all matters relating to the nature of the Work to be undertaken, as to the means of access and egress thereto and therefrom, as to the obstacles to be met with, as to the extent of the Work to be performed and any and all matters which are referred to in the Contract Documents.

3.2 Report any inconsistencies, ambiguities, discrepancies, omissions, and errors between Site conditions and Contract Documents to the Consultant prior to the commencement of Work. If inconsistencies, ambiguities, discrepancies, omissions, and errors are not reported and clarified, the most stringent requirement shall govern, as determined by the Consultant.

3.3 Before commencing the Work of any Section or trade, carefully examine the Work of other Sections and trades upon which it may depend, examine substrate surfaces, and report in writing to the Consultant, defects which might affect new Work. Commencement of Work shall constitute acceptance of conditions and Work of other sections, trades, and Other Contractors upon which the new Work depends. If repair of surfaces is required after commencement of specific work it shall be included in the work of the trade providing the specific system or finish.

3.4 Record and pre-existing site conditions in accordance with TDSB General Requirements.

## **4 USE OF SITE**

4.1 Accept full responsibility for assigned work areas from the time of Contract award until Substantial Performance of the Work.

4.2 Check means of access and egress, rights and interests which may be interfered with. Do not block lanes, roadways, entrances of exits. Direct construction traffic and locate access to site as directed by municipality.

- 4.3 Where encroachment beyond property limits is necessary make arrangements with respective property owners.

## **5 ACCESS/PROPERTY CONSTRAINTS**

- 5.1 Section of the building will remain occupied during construction and will require hoarding. Access route are to be reviewed, approved and maintained during hours of operation. Areas of the work in existing buildings shall be carried on at all times so that there will be minimum interference with the normal function of the facility. Install chain link fencing around work areas. Overhead protection is to be provided at all building entrances/exits adjacent to work areas.
- 5.2 Provide and maintain access facilities as may be required for access to the Work.
- 5.3 Minimize disruption, noise and dust to the functions of existing operational areas of existing buildings. Times of entry, routes of access and time required to complete the Work shall be arranged and scheduled in cooperation with the Owner.
- 5.4 Confine Work and operations of employees to limits indicated by the Contract Documents. Do not unreasonably encumber the premises with products.
- 5.5 Organize delivery of materials/equipment to and removal of debris and equipment from place of Work to permit continual progress of work and suitable for restricted site conditions.
- 5.6 Determine and make arrangement as required for loading and unloading of equipment and Products at times that will not affect public traffic flow and that will be permitted by the TDSB. Conform to City by-laws with regard to parking restrictions and other conditions.
- 5.7 Make provisions and arrangements and provide allowances if times for loading and unloading allowed by the TDSB are other than regular working hours.
- 5.8 All Products, materials and equipment required on Site shall be portable and/or size suitable for access and movement on Site and without causing damage to buildings.
- 5.9 The Work shall be confined to the area defined on the drawings and by the property lines except that services connections and certain portions of landscaping, hard paving and curb work shall be executed on Municipal property under regulation of authorities.
- 5.10 Provide locked doors in barriers, permit access by Owner and Consultant to Work areas and to areas Contractor is responsible for.

## **6 SECURITY**

- 6.1 Be responsible for security of all areas affected by Work of this Contract until taken over by Owner. Take steps to prevent entry to the Work by unauthorized persons and guard against theft, fire and damage by any cause.

- 6.2 Provide suitable surveillance equipment and /or employ guard services, as required to adequately protect the work in accordance with TDSB General Requirements.
- 6.3 Make provisions to permit Owner's security personnel to view areas where all Work is being performed.
- 6.4 Take acceptable precautions to guard Work site, premises, materials and the public during and after working hours due to the Work of this Contract.
- 6.5 Any security service provided by the Owner is for the protection of the Owner's interest in the Work on the Site and shall not relieve the Contractor of the responsibility to protect the Site and the Work of the Contract.

## **7 WEATHER**

- 7.1 Incorporate into the Contract Schedule allowances for the number of working days lost due to inclement weather, which can be anticipated, on the basis of analysis of information available from Environment Canada, for weather conditions on and near the Site, over the last ten (10) years. The Contractor may be entitled to a schedule extension for those activities on the critical path which are delayed on account of inclement weather, assessed on a quarterly basis, by the number of days in excess of the anticipated number of working days for the quarter in question by more than 20%. No additional payment will be made on account of any such schedule extension.
- 7.2 Refer to TDSB Contract Documents for additional information on weather delay.

## **8 WASTE AUDIT/PLANS FOR WASTE REDUCTION**

- 8.1 Comply with requirements of authorities having jurisdiction.
- 8.2 Prepare and submit waste audit and waste reduction plan in accordance with Ontario Regulation 102/94 Waste Audits and Waste Reduction Workplans.
- 8.3 Prepare and submit source separation plan in accordance with Ontario Regulation 103/94 Industrial, Commercial and Institutional Source Separation Programs.
- 8.4 Deliver to nearest appropriate depot all materials accepted for recycling by the region or municipality having jurisdiction over the Place of Work, including but not limited to cardboard, paper, plastic, aluminum, steel, and glass. Deliver to nearest appropriate depot all scrap and excess gypsum wallboard for recycling of this material. Pay all costs for this work.
- 8.5 Refer to TDSB requirements and documents for waste reduction.

END OF SECTION

1. **CASH ALLOWANCES**

- 1.1. Comply with requirements of CCDC 2 G.C. 4.1 Cash Allowances.
- 1.2. Include the Cash Allowances identified in the Tender Price Schedule in the Contract Price. These allowances shall be expended in whole or in part, when authorized by the Consultant in writing. The unused portion of the Allowances shall be credited to the Owner.
- 1.3. The Contract Price and not the cash allowance, includes the Contractor's overhead and profit in connection with such cash allowance. No refund of overhead and profit will be expected on any unspent portion of Cash Allowances. Likewise, no overhead and profit will be allowed on total amount by which all Cash Allowances are exceeded.
- 1.4. Expend cash allowance as directed by the Consultant in writing. Allowance will be adjusted to actual cost but no adjustment will be made to Contractor's charges including overhead and profit which are included in the Contract Price.
- 1.5. Cash allowances are designed for work and services deemed to be necessary by the Owner, from time to time, throughout the execution of the Work. Where a cash allowance refers to an item or category of work already included in the Contract Documents, it shall be assumed to cover work or services in addition to that included, unless specifically indicated otherwise.
- 1.6. Contractor may be required from time to time, to assist in tendering of certain items of work or services covered by allowance, as directed by consultant.
- 1.7. Material Supply Items:
  - 1.7.1. Scope for material supply items covered by Cash Allowance includes:
    - 1.7.1.1. Net cost of material.
    - 1.7.1.2. Applicable taxes and duties excluding HST.
    - 1.7.1.3. Delivery to site.
  - 1.7.2. In addition to above scope covered by Cash Allowance include in Contract Price costs for:
    - 1.7.2.1. Handling at site, including unloading, uncrating, storage and hoisting.
    - 1.7.2.2. Protection from elements, from damage.
    - 1.7.2.3. Labour, installation and finishing.
    - 1.7.2.4. Other expenses required to do cash allowance work (i.e. contract co-ordination).
    - 1.7.2.5. Overhead and Profit.
- 1.8. Material and Installation Items:
  - 1.8.1. Scope of each material and installation item covered by Cash Allowance includes:
    - 1.8.1.1. Net cost of material.
    - 1.8.1.2. Applicable taxes and duties excluding HST.
    - 1.8.1.3. Delivery to site.
    - 1.8.1.4. Handling at site, including unloading, uncrating, storage and hoisting.
    - 1.8.1.5. Labour, installation and finishing.
  - 1.8.2. In addition to above scope covered by Cash Allowance include in Contract Price costs for:
    - 1.8.2.1. Protection from elements, from damage.
    - 1.8.2.2. Overhead and Profit.
    - 1.8.2.3. Other expenses required to do cash allowance work (i.e. contract co-ordination).
- 1.9. Inspection and Testing Work:

- 1.9.1 Scope for inspecting and testing covered by Cash Allowance includes:
  - 1.9.1.1 Net cost of testing laboratory services and field inspection.
  - 1.9.1.2 In addition to above scope covered by Cash Allowance include in Contract Prices:
    - 1.9.1.2.1 Overhead and Profit.
    - 1.9.1.2.2 Supply of material tested, patching and completion of work tested.
    - 1.9.1.2.3 Other testing on re-testing work specified in Section 0140 00.
    - 1.9.1.2.4 Other expenses required to do cash allowance work (i.e. contract co-ordination).
    - 1.9.1.2.5 Applicable taxes and duties excluding HST.
  
- 1.10 Cash allowance -Abatement
  - 1.10.1 Removal and disposal of all existing building materials found to contain designated substances and requiring abatement are to be carried out by an abatement contractor designated by the TDSB. The Contractor will retain the abatement contractor selected by the TDSB and the abatement contractor will be paid through the abatement cash allowance. The Contractor shall allow for the following (which will not be paid through the cash allowance and is considered part of the base bid):
    - 1.10.1.1 The contractor is to provide access to the abatement contractor throughout the demolition and disposal process: This includes access to the work areas, including scaffolding, etc....)
    - 1.10.1.2 The Contractor shall coordinate the work of the designated abatement contractor: and
      - 1.10.1.2.1 The Contractor shall supply and install all necessary hoardings and separations during the abatement process.

END OF SECTION

## 1. PRE-CONSTRUCTION MEETING

- .1 Immediately prior to construction, upon notification attend at location of the Board's choice, pre-construction meeting, along with authoritative representatives of certain key subcontractors as specifically indicated in the conference notice.
- .2 Purpose of meeting is as follows:
  - .1 Review project communications procedures.
  - .2 Review contract administration requirements including submittals, payment and change order procedures.
  - .3 Identify all critical points on construction schedule for positive action.
  - .4 Identify any product availability problems and substitution requests.
  - .5 Establish site arrangements and temporary facilities.
  - .6 Review Consultant's inspection requirements.
  - .7 Review any points which, in Board's, Consultant's and Contractor's opinion, require clarification.
- .3 The Consultant shall organize and chair the pre-construction meeting. Consultant shall record minutes of pre-construction meeting and distribute a copy to each participant within ten days of meeting.

## 2. SITE MEETINGS

- .1 Prior to the commencement of the Work, the Contractor together with the Consultant shall mutually agree to a sequence for holding regular site meetings.
- .2 Organize and chair site meetings. Ensure that persons, whose presence is required, are present and that relative information is available to allow meetings to be conducted efficiently.
- .3 Once a month or more often if directed by the Consultant include a review with Consultant and the Board of construction schedule and application for progress payment, during or immediately following site meeting. Submit to Consultant and sub-consultants a draft progress application not less than 48 hours prior to site meeting.
- .4 Prepare and update for review at each site meeting a change order and shop drawing log.

- .5 Record minutes of each meeting and promptly distribute copies to be received by all participants not later than seven days after meeting has been held.

Distribute minutes of meetings to all Consultants, whether in attendance or not.

### **3. SUPERVISION**

- .1 Employ an experienced and qualified supervisor who shall be in complete charge of the Work from commencement to final completion of the Work and who shall be present at the site whenever work is being carried out. A working foreperson will not be acceptable. The supervisor shall not be changed after commencement of work without the Consultant's approval.
- .2 Supervise, direct, manage and control the work of all forces carrying out the Work, including subcontractors and suppliers. Carry out daily inspections to ensure compliance with the Contract Documents and the maintenance of quality standards. Ensure that the supervisory staff includes personnel competent in supervising all Sections of Work required.
- .3 Arrange for sufficient number of qualified assistants to the supervisor as required for the proper and efficient execution of the Work.

### **4. DOCUMENTS ON SITE**

- .1 Contractor's field office shall at all times contain a complete set of Contract Documents (Drawing and Specifications) with all addenda, site instructions, change orders, reviewed shop drawings and samples, colour schedule, paint materials schedules, hardware list, progress reports and meeting minutes.

### **5. METRIC DIMENSIONS**

- .1 Measurements are expressed in metric (SI) units and depending on the progress made in the various sectors of the industry are either hard or soft converted units.
- .2 All metric units specified shall be taken to be the minimum acceptable unless otherwise noted.
- .3 It is the Contractor's responsibility to check and verify with manufacturers and suppliers on the availability of materials and products in either metric or imperial sizes. Be responsible for coordinating products supplied in metric (SI) and imperial units into the overall layout.
- .4 Where both metric and imperial sizes and dimensions are shown, the metric size or dimension shall govern.

## **BUILDING DIMENSIONS**

- .1 Take necessary job dimensions for the proper execution of the work. Assume complete responsibility for the accuracy and completeness of such dimensions, and for coordination.
- .2 Verify that work, as it proceeds, is executed in accordance with dimensions and positions indicated which maintain levels and clearances to adjacent work, as set out by requirements of the Drawings, and ensure that work installed in error is rectified before construction resumes.
- .3 Check and verify dimensions referring to the work and the interfacing of services.
- .4 Do not scale directly from the Drawings. If there is ambiguity or lack of information, immediately inform the Consultant. Changes through the disregarding of this clause shall be the responsibility of the Contractor.
- .5 All details and measurements of any work which is to fit or to conform with work installed shall be taken at the building.
- .6 Advise Consultant of discrepancies and if there are omissions on Drawings, particularly reflected ceiling plans and jointing patterns for surfaces finishes, which affect aesthetics, or which interfere with services, equipment or surfaces. Do not proceed with work affected by such items without direction from the Consultant.
- .7 Provide written requirements for site conditions and surfaces necessary for the execution of respective work, and provide setting drawings, templates and all other information necessary for the location and installation of material, holes, sleeves, inserts, anchors, accessories, fastenings, connections and access panels. Inform respective contractors whose work is affected by these requirements and preparatory work.

## **6. INTERFERENCE AND COORDINATION DRAWINGS**

- .1 Prepare interference and equipment placing drawings to ensure that all components will be properly accommodated within the spaces provided.
- .2 Prepare drawings to indicate coordination and methods of installation of a system with other systems where their relationship is critical. Ensure that all details of equipment apparatus, and connections are coordinated.
- .3 Ensure that clearances required by jurisdictional authorities and clearances for proper maintenance are indicated on drawings.
- .4 Within 4 weeks of contract award submit interference drawings to Consultant for review.



## **7. SLEEVING AND INSERT SETTING DRAWINGS**

- .1 Prepare sleeving drawings for work of Divisions 15, and 16, showing size and location of all penetrations through load bearing elements. Submit sleeving drawings to Consultant for review not less than 15 days prior to construction of affected elements.
- .2 Prepare insert setting drawings for work to be cast into concrete and/or mortared into masonry elements. Submit insert setting drawings to consultant for review not less than 15 days prior to construction of affected elements.
- .3 Ensure that setting drawings, templates, and all other information necessary for the location and installation of materials, fixtures, equipment, holes, sleeves, inserts, anchors, accessories, fastenings, connections, and access panels are provided by each Section whose work requires cooperative location and installation by other Sections, and that such information is communicated to the applicable installer. Have cutting, fixing and making good to the work of Other Contractors, Subcontractors and trades required for, and make up time lost as result of, failure to comply with this requirement, at no additional cost to Owner.

END OF SECTION

## **1 PRE-CONSTRUCTION MEETING**

- 1.1 Attend a pre-construction meeting, arranged and conducted by the Consultant and TDSB Project Manager.
- 1.2 Co-ordinate and organize attendance by representatives of major Subcontractors and parties in contract with the Contractor.
- 1.3 Consultant will arrange attendance of other interested parties not responsible to the Contractor.
- 1.4 Consultant will distribute copies of Agenda prior to meeting.
- 1.5 Agenda will include but not be limited to the following topics as are pertinent to the Contract.
  - .1 Review project communications procedures.
  - .2 Review contract administration requirements including submittals, payment, and change order procedures.
  - .3 Identify all critical points on construction schedule for positive action.
  - .4 Identify any product availability problems and substitution requests.
  - .5 Establish site arrangements and temporary facilities.
  - .6 Review Consultants' inspection requirements.
  - .7 Review any points which, in Owner's, Consultants, and Contractor's opinion, require clarification.
- 1.6 Be prepared to provide specific information relative to agenda items as they are pertinent to the Contract.
- 1.7 Record minutes of meeting and distribute type written copies to all participants and other interested parties, within one week of meeting date.

## **2 PROGRESS MEETINGS**

- 2.1 Attend regularly scheduled progress meetings to be held on Site at times and dates that are mutually agreed to by the Owner, Consultant, and Contractor.
- 2.2 Co-ordinate and organize attendance of individual Subcontractors and material suppliers when requested. Relationships and discussions between Subcontractor participants are not the responsibility of the Consultant and do not form part of the meetings content.

- 2.3 Ensure that Contractor representatives in attendance at meetings have required authority to commit Contractor to actions agreed upon. Assign same persons to attend such meetings throughout the contract period.
- 2.4 Inform the Consultant in advance of meetings regarding all items to be added to the agenda.
- 2.5 Consultant will distribute copies of Agenda prior to meeting.
- 2.6 Be prepared to provide specific information relative to agenda items at each meeting as they are pertinent to the Contract.
- 2.7 Agenda will include but not be limited to the following topics as are pertinent to the Contract.
  - .1 Review and agreement of previous minutes.
  - .2 Construction safety.
  - .3 Status of submittals.
  - .4 Quality control.
  - .5 Co-ordination.
  - .6 Contract Schedule
  - .7 Work plan up to next scheduled meeting.
  - .8 Requests for information/clarification.
  - .9 Contemplated changes.
- 2.8 Record minutes of meeting and distribute type written copies to all participants and other interested parties, within one week of meeting date.

END OF SECTION

## **1. CONSTRUCTION SCHEDULE**

- .1 Within 14 days of Contract award, submit in format acceptable to Consultant, minimum 6 copies of Contractor's critical path construction schedule.
- .2 Set up format to permit plotting of actual construction progress against scheduled progress.
- .3 Schedule shall show:
  - .1 Commencement and completion dates of Contract.
  - .2 Commencement and completion dates of construction stages/phases, if any.
  - .3 Commencement and completion dates of each trade. Major trades shall be further broken down as directed by Consultant; generally follow Specification format.
  - .4 Order and delivery dates for major or critical equipment.
  - .5 Critical dates for shop drawing/sample submissions.
  - .6 Any other information relating to orderly progress of Contract, considered by Contractor or Consultant to be pertinent.
- .4 Consultant, together with Contractor shall review construction progress once a month during or immediately following regular site meeting, or more often as directed by Consultant.
- .5 Update construction schedule, whenever changes occur, in manner and at times acceptable to Consultant.
- .6 Plot actual construction progress or schedule at least once a week.
- .7 Submit copy of updated schedule to Consultant once a month, concurrently with application for payment.

## **2. CASH FLOW CHART**

- .1 Within 7 days after award of Contract, submit, in form approved by Consultant, cash flow chart broken down on a monthly basis in an approved manner. Cash flow chart shall indicate anticipated Contractor's monthly progress billings from commencement of work until completion.
- .2 Update cash flow chart whenever changes occur to scheduling and in manner and at times satisfactory to Consultant.

**3. PROGRESS RECORD**

- .1 Maintain on site, permanent written record of progress of work. Record shall be open to inspection by Consultant at all times and copy shall be furnished to Consultant upon request.
- .2 This record shall show weather conditions dates of commencement, progress and completion of various trades and items of work. Particulars pertaining to erection and removal of forms, pouring of concrete, installation of roofing and other critical or major components as well as number of employees of various trades and type and quantity of equipment employed daily, shall be noted.
- .3 Display a copy of the construction schedule in the site office from start of construction to completion. Superimpose actual progress of work on schedule at least once each week.

**4. RECORD DRAWINGS**

- .1 Obtain and keep on site at all times a complete and separate set of black line white prints.
- .2 Note clearly, neatly, accurately and promptly as the work progresses all architectural, structural mechanical and electrical changes, revisions and additions to the work and deviations from the Contract Documents.
- .3 Accurate location, depth, position, size and type of concealed and underground services, both inside and outside shall be included as part of these record drawings.
- .4 Record drawings shall be available for review at each site meeting.
- .5 Refer to drawings for additional requirements.

**5. PROGRESS PHOTOGRAPHS**

- .1 Concurrently with monthly application for payment submit two sets of 200 mm x 250 mm coloured, glossy paper photographs or digitally in jpg format as follows:
  1. Up to four photographs shall be taken from positions determined by Consultant.
  2. Photographs shall be properly exposed and in focus; views shall be unobstructed.
  3. Identify each photograph stating name of project, name of photographer, description of view and date of photograph taken.

**6. CERTIFIED SURVEY PLAN**

.1 Reserved

**7. PRODUCT DELIVERY CONTROL**

1. It is the responsibility of the Contractor to ensure that the supplier or distributor of materials specified or alternatives accepted, which he intends to use, has materials on the site when required. The Contractor shall obtain confirmed delivery dates from the supplier.
2. Provide equipment delivery schedule, coordinated with construction and submittals' schedule, showing delivery dates for major and/or critical equipment.
3. The Contractor shall contact the Consultant immediately upon receipt of information indicating that any material or item, will not be available on time, in accordance with the original schedule, and similarly it shall be the responsibility of all subcontractors and suppliers to so inform the Contractor.
4. The Consultant reserves the right to receive from the Contractor at any time, upon request, copies of actual purchase or work orders of any material or products to be supplied for the work.
5. If materials and products have not been placed on order, the Consultant may instruct such items to be placed on order, if direct communication in writing from the manufacturer or prime suppliers is not available indicating that delivery of said material will be made in sufficient time for the orderly completion of the Work.
6. The Consultant's review of purchase orders or other related documentation shall in no way release the Contractor, or his subcontractors and suppliers from their responsibility for ensuring the timely ordering of all materials and items required, including the necessary expediting, to complete the work as scheduled in accordance with the Contract Documents.

END OF SECTION

**1 GENERAL**

- 1.1 Provide labour, Products, equipment, services tools and supervision necessary for submittals. Make submittals specified in this Section to Consultant unless otherwise specified.
  - .1 Verify accuracy and completeness of submittals prior to submission.
  - .2 Verify field measurements, field construction criteria, catalogue numbers and similar data.
  - .3 Co-ordinate each submittal with requirements of the Work and the Contract Documents.
  - .4 Notify Consultant in writing at time of submission, of any deviation in submittals from requirements of the Contract Documents.
- 1.2 Submit in accordance with dates established under Section 01 32 00 for shop drawings, fabrication, manufacture, erection and installation to provide adequate time for reviews, securing necessary approvals, possible revisions and resubmittals, placing orders, securing delivery and to avoid construction delays.
- 1.3 Accompany each submittal with a letter of transmittal in duplicate containing all pertinent information required for identification and checking of submittals including but not limited to the following:
  - .1 Date of initial submission and date of each subsequent submission if required.
  - .2 Project title and Consultant's project number.
  - .3 Names of:
    - .1 Contractor.
    - .2 Subcontractor.
    - .3 Supplier/manufacturer as applicable.
  - .4 Specification section numbers to which submission is related.
  - .5 Countersigned stamp of Contractor certifying that they have reviewed the submission.
- 1.4 Allow two weeks for the Consultant's review of each submission.
- 1.5 When submittals are resubmitted, transmit under a new letter of transmission.
- 1.6 Do not carry out Work until Consultants review of submittals has been completed.
- 1.7 Be responsible for payment of charges for delivery of submissions and resubmission to Consultant.

## **2 PRODUCT DATA**

- 2.1 Before delivery of Products to the Site, submit Product data as specified in each section or as requested by the Consultant.
- 2.2 Submit manufacturer's Product data for systems, materials, and methods of installation proposed for use. Such literature shall identify systems, each component, and shall certify compliance of each component with applicable standards.

## **3 SAMPLES**

- 3.1 Before delivery of Products to the Site, submit samples of Products as specified or as requested by the Consultant. Label samples as to origin and intended use in the Work and in accordance with the requirements of the Specification Sections. Samples must represent physical examples to illustrate materials, equipment or work quality and to establish standards by which completed Work is judged.
- 3.2 Ensure samples are of sufficient size and quantity, if not already specified, to illustrate:
  - .1 The quality and functional characteristics of Products, with integrally related parts and attachment devices.
  - .2 Full range of colours available.
- 3.3 Notify the Consultant in writing, at time of submission, of any deviations in samples from requirements of the Contract Documents, and state the reasons for such deviations.
- 3.4 Identify samples with Project name, Contract number, date, Contractor's name, number and description.
- 3.5 If samples are not acceptable, both samples will be returned. If samples are acceptable, one sample will be so indicated and returned. Be responsible for the cost of samples that are not accepted and for resubmission of samples.
- 3.6 Acceptable samples shall serve as a model against which the products incorporated in the work shall be judged.
- 3.7 Each Product incorporated in the Work shall be precisely the same in all details as the acceptable sample.
- 3.8 Should there be any change to the accepted sample, submit in writing for approval of the revised characteristics and resubmit samples of the Product for approval if requested.
- 3.9 When samples are very large, require assembly, or require evaluation at the Site,



they may be delivered to the Site, but only with approval and as directed.

#### **4 SHOP DRAWINGS**

- 4.1 Arrange for the preparation of shop drawings as called for in the Contract Documents or as may be reasonably requested by the Consultant. The Contractor and each Subcontractor shall operate as experts in their respective fields and all shop drawings and samples shall conform to the requirements of the Contract Documents.
- 4.2 The term 'shop drawings' means drawings, diagrams, schematics, illustrations, schedules, performance charts, brochures and other data which are required to illustrate details of the Work.
- 4.3 In addition to shop drawings specified in the specification sections, submit shop drawings required by jurisdictional authorities in accordance with their requirements.
- 4.4 Shop drawings for openings, sleeving and conduit.
  - .1 Prior to preparation of shop drawings, coordinate sizes of all structural openings and sleeves with respective fabricators for mechanical ducting. Adjustments to the opening sizes indicated on the Contract Drawings shall not be made without the approval of the Consultant.
  - .2 Prior to detailing structural reinforcement on shop drawings, arrange for the Engineer of structure to review formed holes, recesses and sleeving. Completely dimension openings, recesses and sleeves and relate to suitable grid lines and elevation.
  - .3 Prior to forming of the structure, arrange for the preparation of shop drawings for review by the Consultant showing embedded conduit to be cast within the structure. Shop drawings shall include conduit from all sources.
- 4.5 Shop drawings shall indicate the following minimum criteria and any additional criteria indicated in the individual specification sections requiring shop drawings:
  - .1 Clear and obvious notes of any proposed changes from the Contract Documents.
  - .2 Fabrication and erection dimension.
  - .3 Provisions for allowable construction tolerances and deflections provided for live loading.
  - .4 Details to indicate construction arrangements of the parts and their connections, and interconnections with other work.
  - .5 Location and type of anchors and exposed fastenings.
  - .6 Materials, physical dimensions including thicknesses, and finishes.
  - .7 Descriptive names of equipment.

- .8 Mechanical and electrical characteristics when applicable.
- .9 Information to verify that superimposed loads will not affect function, appearance, and safety of the work detailed as well as of interconnection work.
- .10 Assumed design loadings, and dimensions and material specifications for load-bearing members.
- 4.6 Include in shop drawing submissions detailed information, templates, and installation instructions required for incorporation and connection of the Work.
- 4.7 Before submitting to the Consultant, review all shop drawings to verify that the Products illustrated therein conform to the Contract Documents. By this review, the Contractor agrees that it has determined and verified all field dimensions, field construction criteria, materials, catalogue numbers and similar data and that it has checked and coordinated each shop drawing with the requirements of the Work and of the Contract Documents. The Contractor's review of each shop drawing shall be indicated by stamp, date and signature of a qualified and responsible person possessing the appropriate authorization.
- 4.8 Be responsible for dimensions to be confirmed and correlated at the Site, for information that pertains solely to fabrication processes or to techniques of construction and installation and for coordination of the Work of all subtrades.
- 4.9 Submit shop drawings for the Consultant's review with reasonable promptness and in orderly sequence so as to cause no delay in the Work nor in the work of Other Contractors. At the time of submission, notify the Consultant in writing of any deviations in the shop drawings from the requirements of the Contract Documents. The Contractor will be held responsible for changes made from the Contract Documents which are not indicated or otherwise communicated in writing with the submission.
- 4.10 Drawings submitted by the Contractor as required herein are the property of the Owner who may use and duplicate such drawings where required in association with the Work.
- 4.11 Submit shop drawings, as indicated in each section of the Work, signed and sealed by a licensed Professional Engineer registered in the place of the Work.
- 4.12 Shop drawings shall have distinct, uniform letters, numerals and line thicknesses that will ensure the production of clear legible prints and also facilitate microfilming and reduced reproduction.
- 4.13 Submit shop drawings in PDF format. However, in instances where catalogue items are specified, three clean copies of the manufacturer's catalogue may be submitted.
- 4.14 Shop drawings shall contain the following identification:
  - .1 Project name and Contract number.

- .2 Applicable 6-digit Contract Specification number describing the item.
- .3 Location (unit, level, room number, etc.).
- .4 Name of equipment or Product.
- .5 Name of Subcontractor or supplier.
- .6 Signature of Contractor certifying that Shop drawing is in conformance with Contract Documents.
- .7 On submissions subsequent to the first, the following additional identification:
  - .1 The revision number.
  - .2 Identification of the item(s) revised.
  - .3 Building address.
  - .4 Project name.
  - .5 Owner's name.
  
- 4.15 Dimensions and designations of elements shall be shown in the same system of measurement used on the applicable Contract Drawings.
- 4.16 The Consultant reserves the right to refuse acceptance of drawing submissions not meeting the above requirements.
- 4.17 The Consultant's review will be for conformity to the design concept and for general arrangement only and such review shall not relieve the Contractor of responsibility for errors or omissions in the shop drawings or of responsibility for meeting all requirements of the Contract Documents unless a deviation on the shop drawings has been approved in writing by the Consultant.
- 4.18 The Contractor shall make any changes in shop drawings which the Consultant may require consistent with the Contract Documents and re-submit unless otherwise directed by the Consultant. When re-submitting the shop drawings, the Contractor shall notify the Consultant in writing of any revisions other than those requested by the Consultant.
- 4.19 Only drawings noted for revision and resubmission need be resubmitted.
- 4.20 File one copy of each submitted shop drawing at the Site.
  
- 5 CERTIFICATES**
- 5.1 Submit certificates that are required by authorities having jurisdiction or that are requested in the specification sections.
- 5.2 Clearly show on each certification the name and location of the Work, name and address of Contractor, quantity and date of shipment and delivery and name of certifying company.

- 5.3 Certificates shall verify that Products and/or methods meet the specified requirements and shall include test reports of acceptable testing laboratories to validate certificates.
- 5.4 Submit certificates in duplicate and signed by an authorized representative of the certifying company.
- 5.5 Product manufacturer's to certify in writing that the products supplied for this project are in accordance with the Contract Documents.

## 6 **CERTIFICATION OF TRADESMEN**

- 6.1 Provide certificates, at the request of the Consultant, to establish qualifications of personnel employed on the Work where such certification is required by authorities having jurisdiction, by the Consultant or by the Contract Documents.

## 7 **WARRANTIES**

- 7.1 Submit extended warranties as requested in sections of the Specifications showing title and address of Contract, warranty commencement date and duration of warranty.
- 7.2 Extended warranties shall commence on termination of the standard warranty specified in the conditions of the contract and shall be an extension of these provisions. Clearly indicate what is being warranted and what remedial action is to be taken under the warranty. Ensure warranty bears the signature and seal of the Contractor.
- 7.3 Submit each extended warranty on a form that is acceptable to the Owner and Consultant.
- 7.4 Standard warranty as noted in TDSB General Conditions.

## 8 **INSPECTION AND TEST REPORTS**

- 8.1 Submit inspection and test reports as specified in the Sections of the specifications for 'Source Quality Control' and 'Field Quality Control' within 3 working days of inspection or testing. If immediate action is required by the Contractor or Consultant inform the Consultant immediately and submit inspection and testing report within one working day.
- 8.2 Submit reports in PDF format submitted with certificates of compliance indicating but not limited to the following clearly and legible:
- .1 Project address.
  - .2 Building Owner.
  - .3 Date of inspection or test and date report is issued.

- .4 Name and address of inspection and testing company.
  - .5 Name and signature of inspector or tester.
  - .6 Identification of Product and Specification Section covering inspected or tested work.
  - .7 Specified requirements for which the inspection or testing was performed and results of inspections or tests.
  - .8 Location of inspection or from which tested material was derived.
  - .9 Overview of inspection and testing methods and procedures.
  - .10 Remarks and observations on compliance with Contract Documents.
- 8.3 Inspection and test reports shall be signed by a responsible officer of the inspection and testing company.

**9 PROGRESS PHOTOGRAPHS**

- 9.1 Concurrently with monthly application for payment submit photographs via email complete with date stamp as follows:
- .1 Up to 4 photographs shall be taken from positions determined by Consultant.
  - .2 Photographs shall be properly exposed and in focus; view shall be unobstructed.
  - .3 Identify each photograph on back stating name of project, name of photographer, description of view and date of photograph taken.

**10 PROGRESS REPORTS**

- 10.1 Prepare a monthly progress report current to the last Friday of each month. The report shall indicate the period covered and include but not be limited to the following:
- .1 Executive Summary.
  - .2 Areas of Concern/Action Required.
  - .3 Work Accomplished This Period.
  - .4 Work Planned Next Period.
  - .5 Schedule Status.
  - .6 Budget Status.
  - .7 Status of Submittals.

- .8 Quality Control.
- .9 Contract Changes.
- .10 Outstanding Actions.
- 10.2 Submit the monthly progress report such that it is received by the Consultant no later than the Wednesday following the last Friday of the month, regardless of whether or not the Monday is a public holiday.
- 11 OPERATION AND MAINTENANCE MANUALS**
- 11.1 Submit Operation and Maintenance Manuals in accordance with Section 01 78 23 and TDSB requirements.
- 12 RECORD DOCUMENTS**
- 12.1 Submit record documents in accordance with Section 01 78 00 and TDSB requirements.

END OF SECTION

## **PART 1 GENERAL**

### **1.1 Description**

- .1 This Section outlines the mandatory minimum Health and Safety protocols for all renovation, addition and new school construction Projects where all or a portion of the existing school building remains occupied and in use.
- .2 These Health and Safety protocols are mandatory minimum requirements, procedures and standards that the Board insists are fully complied with by all parties involved with Board Projects.

### **1.2 Related Sections**

- .1 These specifications apply to all Divisions of this Project specification. It is the responsibility of the Contractor to apply these provisions wherever practical within specification limits to all products and services used on this Project.
- .2 The requirements of this Section supersede those of all other specification Sections and Drawings. Where conflicts exist in procedures, methods or materials, they shall immediately be brought to the attention of the Consultant and Board. Where clarification is not immediately available, the Contractor shall assume the specifications contained in this Section are a minimum standard and the more stringent specification shall apply.
- .3 The Contractor must receive approval from Board Project Manager for any deviations from this specification Section.
- .4 The General Contractor shall recognize that it is *he* who is the Constructor of the Project. The General Contractor shall also recognize that he is solely responsible for site safety at the Place of the Work and compliance with the requirements of this Section does not limit or remove his total responsibility for site safety as Constructor of the Project.

### **1.3 References**

- .1 Applicable related regulations, standards and laws related to safety include but are not limited to:
  - .1 Canada Labour Code, Part 2, Canada Occupational Safety and Health Regulations.
  - .2 Health Canada/Workplace Hazardous Materials Information System (WHMIS).
    - .1 Material Safety Data Sheets (MSDS).
  - .3 Province of Ontario
    1. Occupational Health and Safety Act and Regulations for Construction Projects, R.S.O. [current edition].

### **1.4 Compliance Specification**

- .1 Notwithstanding the requirements of this Section, the Contractor must comply with all applicable health, safety and environmental regulations and statutes.

### **1.5 Beyond Compliance Specification**

- .1 These specifications apply in addition to all applicable health, safety and environmental compliance regulations. They are incorporated here to reflect the Board's intention to develop a specification which provides the safest practical procedures and policies for construction project sites that are occupied and in use by staff, students and visitors during the execution of the Construction Contract.

- 2 Beyond compliance specifications recognize that performance well beyond the minimum regulatory standard is often desirable, possible and affordable, often with no cost or low cost options. It also recognizes that application methods or protocols may be as important as the material specified. Therefore, these specifications cover both material and methods.
- 3 These provisions apply to both indoor and outdoor applications equally.

## **PART 2 PRODUCTS**

- 2.1 Not Used.

## **PART 3 EXECUTION AND COMPLIANCE REQUIREMENTS**

### **3.1 Application of Compliance Requirements**

- .1 The articles set out herein are to be applied together as a set of related policies and procedures to achieve a comprehensive Health and Safety working protocol.
- .2 The Contractor shall execute all of the procedures and meet all of the requirements set out herein and apply these protocols from the outset of the Construction Phase.
- .3 These procedures or requirements are to be maintained for the duration of the Construction Phase. The Contractor shall not discontinue any of the individual procedures or requirements without the prior approval of the Board Project Manager.

### **3.2 Site Supervisor (Site Superintendent)**

- .1 A full-time Site Supervisor (Site Superintendent) is required for each site at any site, regardless of the number of active workers on site.
- .2 Site Superintendent shall have as a minimum:
  - .1 Recent, previous experience with renovation or addition projects involving occupied buildings including (but not limited to) school construction, sites with students, tenants, employees, retail customers, pedestrian and vehicular traffic.
  - .2 Successful completion of a multi-session Supervisor's training course conducted by a recognized Construction Association in Ontario.
- .3 Site Superintendent must carry a cell phone at all times during construction with the ability to be reached directly during all work hours and the ability to have voicemail recorded during all non-work hours including weekends and holidays.
- .4 Site Superintendent must have means of live phone or walkie-talkie communication with the site Flagman during all work hours.
- .5 Site Superintendent shall not be changed throughout project unless confirmed and approved by the Board Project Manager.

### **3.3 Ontario Occupational Health & Safety Act and Regulations for Construction Projects**

- .1 General Contractor to comply with the Ontario Occupational Health & Safety Act and Regulations for Construction Projects, latest edition—including all amendments.
- .2 Beyond compliance in item .1 above, regardless of the number of labourers active on the Project, the General Contractor shall form a contractors' Health & Safety Committee at the outset of construction. This Committee shall then follow the standard requirements for such a Committee as set out in the *Occupational Health & Safety Act and Regulations for Construction Projects*.



### 3.4 On-Site Communications

- .1 At the outset of the project the General Contractor shall provide to the Board Project Manager all relevant contact information for the Site Superintendent, GC Project Manager and key sub-contractors including names and cell phone numbers.
- .2 The General Contractor shall provide at least one “emergency contact” telephone number at which the Contractor’s representative can be reached directly during all work hours and have the ability to have voicemail recorded during all non-work hours including weekends and holidays. As outlined below, this may be designated to the Site Superintendent’s cell phone number.
- .3 Regardless of compliance method for the emergency contact telephone number stated above, the Site Superintendent must carry a cell phone at all times during construction with the ability to be reached directly during all work hours and the ability to have voicemail recorded during all non-work hours including weekends and holidays.
- .4 Site Superintendent must have means of live phone or walkie-talkie communication with the site Flagman during all work hours.
- .5 The Contractor is to ensure that the Board Project Manager is immediately apprised of any safety issues as each arises and the related request and/or resolution. The Board Project Manager is responsible for any decisions that have an effect on the contract execution.
- .6 Notwithstanding the reporting to the Project Manager noted above the Site Superintendent shall liaise with school principal or designate on all safety related matters as required on a daily basis.
- .7 In the event of a safety issue requiring contractual clarification or action (i.e. Change Notice, etc.), the contractor shall ensure that, where applicable, the action is followed up with appropriate documentation.

### 3.5 Full-Time On-Site Flagmen

- .1 A full-time, designated Flagman is required at all vehicular construction entrances.
- .2 In the event there is more than one entrance to the hoarded/fenced construction area, there must be a separate Flagman for each entrance.
- .3 Flagman may not be same person as Site Superintendent or other construction worker.
- .4 Flagman shall not be changed throughout the Project unless confirmed and approved by the Board Project Manager.
- .5 Flagman must have means of phone communication with Site Superintendent (phone or walkie-talkie).
- .6 The Flagman shall not be designated for any other duties than to act as a Flagman for safety purposes as described herein.
- .7 The Flagman shall meet and escort any construction traffic from the site **entrance** into and out of the hoarded/fenced construction area (including through open site areas until entrances to hoarding).
- .8 The Flagman shall only open hoarded areas when construction traffic moves through and immediately re-close gates.
- .9 The Flagman shall control construction parking at the school site (including vehicles parking or traveling in unauthorized areas).
- .10 The location of the Flagman shall be set to ensure the safe guarding of staff, student, and pedestrian traffic.
- .11 If not designated on the Contract Documents, the location of the Flagman shall be confirmed with the Board Project Manager and Consultant at the outset of the project and before the placement of hoarding and fencing.
- .12 Where the Contractor deems it necessary, in order for the Flagman to carry out the required full-time duties, the cost of a temporary shelter shall be included in the Tender Price.
- .13 The Flagman shall be properly attired to carry out his duties, including the use of safety equipment (e.g. wear reflective vest, have appropriate traffic hand-held “Stop” sign and have a visible identification tag).

### 3.6 Site Safety Signage

- .1 Standardized Safety Signage is required at all construction entrances. Refer to detail drawings for types and requirements.
- .2 If not designated on the Contract Documents, the location of the Safety Signage shall be confirmed with the Board Project Manager and Consultant at the outset of the Project and before the placement of hoarding and fencing.
- .3 Safety Signage is to be posted at all street entrances to school site and at each entrance to hoarded/fenced construction area.
- .4 Total surface area of signage is to avoid exceeding municipal standards that would require a separate signage permit.
- .5 Access signage text shall include cell phone contact number for Site Superintendent.
- .6 Signage posted at gates shall state restrictions on hours of entry and egress as described in the Contract Documents and under no circumstances shall construction traffic be allowed within 30 minutes prior to school start, during recess, lunch break, and 30 minutes after dismissal periods.

### 3.7 Access/Egress Controls

- .1 At the outset of the Contract, the General Contractor shall advise all suppliers and subcontractors of the protocols listed herein and of the requirement to contact the Site Superintendent by Cell phone prior to entering the site.
- .1 The drivers of all construction vehicles entering the site, including delivery vehicle drivers, are to contact site Superintendent by cell phone prior to entering site; the Site Superintendent shall, in turn, give notice to the Flagman to be aware of the traffic and authorize the Flagman to allow entry of that vehicle.
- .2 Vehicular Gates are only for entry and exit of for construction purposes such as construction personnel, Authorities performing inspections, Board representative, delivery personnel, and disposal pickup and ONLY under escort by the Flagman. As such vehicular gates must remain closed and locked at all times and only opened for access/egress under escort by the Flagman, then closed and locked again.
- .3 Gates are to be lockable swing gates for vehicles and man gates at all access points to the hoarded/fenced construction area.

### 3.8 Contractor Parking

- .1 Contractor parking shall be restricted to hoarded areas or designated parking areas only where pre-approved by Board Project Manager and Principal.
- .2 Contractor parking is restricted from all off-site street areas that interfere with site specific parent drop-off and parking areas.

### 3.9 Required Preconstruction Meetings

- .1 Meeting 1: Contractor shall receive approval from the Architect and the Board Project Manager for parking, vehicular movement, access/egress strategies at a Pre- construction meeting taking place in advance of mobilizing on site.
- .2 Meeting 2: Once hoarding and fencing is erected BEFORE site construction is fully active and vehicles or equipment is mobilized on site, an initial site meeting shall take place at which time the layout of trailers and staging, deliveries, storage of materials, parking areas and vehicular movement to be reviewed and approved by the Board Project Manager.
- .3 See article 3.12- 'Site Meetings' following.

### 3.10 Construction Fencing and Hoarding

- .1 Construction hoarding requirements shall be a site based decision to be determined by the

- Architect and the Board Project Manager at the design stage and shown on Contract Documents.
- .2 No fencing or hoarding shall be less than a continuous 2400 mm high.
  - .3 In portions of the site where chain link is approved, it shall be continuous 2400 mm high chain link fencing, wire-tied to staked iron 'tees' at 1800 mm on centre - OR - leased, modular 'quick fencing' if staked down and wire tied together.
  - .4 All fenced and hoarded areas to be gated with lockable vehicular and man gates- minimum construction to be steel rail and chain link construction.
  - .5 Plastic snow fencing is NOT permitted.
  - .6 All hoarding and fencing shall be maintained in a stable condition, for duration of construction period as part of the base contract price and to include Superintendent's inspection at the beginning and end of each work day.
  - .7 All Fire Routes to be outside all fenced and hoarded areas and maintained clear at all times.
  - .8 'Covered way' protection shall be provided when accesses or pathways are in proximity to construction, in accordance with Ministry of Labour *Occupational Health & Safety Act* Regulations.

### 3.11 Board Health, Wellness & Safety Department Representative

- .1 A representative of the Board's Health, & Safety Dept. ('Environment, Health and Safety Officer') may visit site at any anytime throughout the duration of the Contract to review the site, as it relates to the safety of the occupied areas of the site. Such site review shall neither constitute an inspection or approval for the Contractor.
- .2 Concerns or issues identified by the representative from the Board's Health, Wellness & Safety Dept. shall be communicated through the Board Project Manager and the school Principal for corrective action.
- .3 Contractor shall ensure full access to all site areas, at all times, for the Board's Health, Wellness & Safety Department Representative.

### 3.12 Site Meetings

- .1 Initial site meeting to take place after erecting fencing and hoarding but prior to the mobilization of any vehicles, equipment or start of Work.
- .2 Contractor shall ensure that the Board Project Manager, School Principal and a representative of the Board's Health, Wellness & Safety Department and the School Principal attend the initial site meeting.
- .3 The initial meeting shall review and approve a standardized agenda for all site meetings and a thorough review of the Site Safety Protocol.
- .4 The standardized agenda shall include a Checklist and Report of Health and Safety items at the beginning of the agenda. This Checklist shall be included and each item reviewed at all site meetings for the duration of the project.
- .5 The Checklist of Site Safety items shall include but not be limited to:
  - .1 Contractor's report of site safety record and report of recent site activities, precautions or actions.
  - .2 Review any visits to the site and actions required by Ministry of Labour or Board Health, Wellness & Safety representatives or other Authorities Having Jurisdiction.
  - .3 Contractor's Health & Safety policy manual posted in site trailer.
  - .4 Copy of Ministry of Labour *Occupational Health & Safety Act and Regulations for Construction Projects* in site trailer.
  - .5 Name of General Contractor H&S representative.
  - .6 Continuing compliance with Safety Signage.
  - .7 Hoarding & fencing layout and condition.
  - .8 Access and egress measures and any breaches of requirements.
  - .9 Confirmation of communications link between Site Superintendent & Flagman.
  - .10 Work that may produce any noxious odours and the containment measures, (*i.e.*: schedule, type, approvals required therefore).

- .11 Copies of Material Safety Data sheets in site trailer.
- .12 Complete meeting minutes including details of Safety Checklist shall be copied to Architect, Board Project Manager and Principal.
- .6 Contractor to produce record of written Memorandum to all subtrades and suppliers detailing but not limited to: hours of delivery; site access procedures and restrictions; use of existing facilities.
- .7 Contractor to prepare detailed and accurate written record of all meetings to be kept and issued to all parties.

### **3.13 Contractor's Health and Safety Committee Meetings**

- .1 As required in item 3.1.2, the Contractor shall form a Health and Safety Committee, hold meetings and record minutes of meetings for the duration of the Contract.
- .2 Contractor to maintain a copy of Health & Safety Committee minutes on site for review by Ministry of Labour or Board representative(s).

**END OF SECTION**

## **1 GENERAL**

- 1.1 Be responsible for inspection and testing as required by the Contract Documents, statutes, regulations, by-laws, standards or codes or any other jurisdictional authority. Give the Consultant timely notice of the readiness for inspection, date and time for such inspection for attendance by the Consultant.
- 1.2 Verify by certification that specified products meet the requirements of reference standards specified in the applicable specification sections.
- 1.3 Conduct testing, balancing and adjusting of equipment and systems specified in applicable mechanical and electrical specifications sections by independent testing company.

## **2 INSPECTION AND TESTING BY THE OWNER**

- 2.1 The Contractor must cover all costs for an independent inspection and testing company to carry out inspection and testing of the Work for conformance to the Contract Documents. Such costs for inspection and testing will be paid by the Contractor. However, any additional inspection and testing due to non-conformance to the Contract Documents shall be at the Contractor's expense.
- 2.2 Inspections and testing by the Contractor will be promptly made. Uncover for examination any Work covered up prior to inspection or without approval of the Consultant. Make good such Work at no cost to the Owner.
- 2.3 The Owner may inspect and test Products during manufacture, fabrication, shop testing, installation, construction and testing phases of the Contract. The Consultant will ascertain the quantity and quality of testing to be performed. Inspection and testing may be performed at the place of manufacture/fabrication, storage, or at the Site as designated by the Consultant. Where inspection and testing is done either during manufacture, fabrication, or at Site, ensure that proper facilities and assistance are provided.

## **3 INSPECTION AND TESTING**

- 3.1 Source and Field Quality Control specified in Other Sections:
  - .1 This Section includes requirements for performance of inspection and testing specified under Source Quality Control and Field Quality Control in other Sections of the specifications.
  - .2 Do not include in work of this Section responsibilities and procedures that relate solely to an inspection and testing company's functions that are specified in another Section which is paid for directly by the Contractor. Such information is included in this Section for Contractor's information only.

- 3.2 Do not limit responsibility for ensuring that products and execution of the work meet Contract requirements, and inspection and testing required to this end, to specified inspection and testing.
- 3.3 Arrange for inspection of all work by authorities having jurisdiction. Submit final unconditional certificate of approval by inspecting authorities.
  - .1 Provide Consultant and DDSB's Project Manager 24 hours notice of date when tests will occur.
  - .2 Do not conceal work until tested and approved.
  - .3 Re-testing and re-inspections of work found deficient, and costs of making good, shall be paid for by the Contractor.

#### **4 QUALIFICATIONS OF INSPECTION AND TESTING COMPANIES**

- 4.1 Inspection and testing companies to be certified by the Standards Council of Canada.
- 4.2 Companies engaged for inspection and testing shall provide equipment, methods of recoding and evaluation, and knowledgeable personnel to conduct tests precisely as specified in reference standards.
- 4.3 If requested, submit affidavits and copies of certificates of calibration made by an accredited calibrator to verify that testing equipment was calibrated and its accuracy ensured within the previous twelve months.

#### **5 RESPONSIBILITIES OF THE CONTRACTOR**

- 5.1 Be responsible for quality control methods and procedures to ensure performance of the work in accordance with the Contract Documents.
- 5.2 Perform Inspection and Testing in accordance with the Contract Documents.

#### **6 RESPONSIBILITIES OF INSPECTION AND TESTING COMPANIES**

- 6.1 Determine from specifications and Drawings the extent of inspection and testing required for Work of the Contract. Subcontractors shall notify Consultant of any omissions or discrepancies in the work inspected and/or tested.
- 6.2 Perform applicable inspection and testing described in the Specifications and as may be additionally directed.
- 6.3 Provide competent inspection and testing personnel when notified by the Contractor that applicable work is proceeding. Inspection personnel shall cooperate with the Consultant and Contractor to expedite the Work.

6.4 Subcontractors shall notify the Consultant and Contractor of deficiencies and irregularities in the Work immediately when they are observed in the course of inspection and testing.

6.5 Inspection and testing companies shall not perform or supervise any of the Contractor's work, and shall not authorize:

.1 Performance of work that is not in strict accordance with the Contract Documents.

.2 Approval or acceptance of any part of the Work.

## **7 INSPECTION AND TESTING PROCEDURES**

7.1 Perform specified inspection and testing only in accordance with specified reference standards, or as otherwise approved.

7.2 Observe and report on compliance of the Work to requirements of Contract Documents.

7.3 Ensure that inspectors are on site or at fabricator's operations for full duration of critical operations, and as otherwise required to determine that the Work is being performed in accordance with the contract Documents.

7.4 Identify samples and sources of materials.

7.5 Review and report on progress of the work. Report on count of units fabricated and inspected at fabricator's operations.

7.6 Observe and report on conditions of significance to work in progress at time of inspection or at fabricator's operations. Include where applicable and if critical to the work in progress:

.1 Time and date of inspection.

.2 Temperature of air, materials, and adjacent surfaces.

.3 Humidity of air, and moisture content of materials and adjacent materials.

.4 Presence of sunlight, wind, rain, snow and other weather conditions.

7.7 Include in reports all information critical to inspection and testing.

7.8 Ensure that only materials from the work and intended for use therein are tested.

7.9 Prepare a list of elements to be inspected and review this with City and Consultant for conformance to the specifications.

## **8 TOLERANCES FOR INSTALLATION OF WORK**

- 8.1 Unless specifically indicated otherwise, work shall be installed plumb, level, square and straight.
- 8.2 Unless acceptable tolerances are otherwise specified in specification sections or are otherwise required for proper functioning of equipment, site services, and mechanical and electrical systems:
- .1 "Plumb and level" shall mean plumb or level within 1 mm in 1 m.
  - .2 "Square" shall mean not in excess of 10 seconds lesser or greater than 90 degrees.
  - .3 "Straight" shall mean within 1 mm under a 1 m long straightedge.
  - .4 "Flush" shall mean within:
    - .1 6 mm for exterior concrete and paving materials.
    - .2 1 mm for interior concrete and similar surfaces.
    - .3 0.05 mm for other interior surfaces.
- 8.3 Allowable tolerances shall not be cumulative.

## **9 REFERENCE STANDARDS**

- 9.1 Perform inspection and testing in accordance with Standards quoted and as required by procedures described in specified reference standards that are applicable to the work being inspected and tested.

## **10 DEFECTS**

- 10.1 Defective products, materials and workmanship found at any time prior to Contract Completion will be rejected regardless of previous inspections, testing, and reviews of the Work. Inspections, testing, and reviews shall not relieve the Contractor from their responsibility, but are a precaution against oversight or error. Remove and replace defective and rejected products, materials, systems, and workmanship. Be responsible for delays and expenses caused by rejection.

## **11 MOCK UPS**

- 11.1 Where required by Contract Documents construction, unless indicated herein, mock-ups of work on Site, in size and at location directed by Consultant.
- 11.2 Construct mock-ups prior to start of affected work. Allow sufficient time for Consultant's review. Work affected by mock-ups may not commence prior to acceptance of mock-ups.
- 11.3 Construct mock-ups to include all related specified materials and workmanship. Make revisions as directed by Consultant, in accordance with the intent of the Contract Documents, until mock-ups are acceptable.



- 11.4 Mock-ups, reviewed and accepted by Consultant, shall become the standard of quality against which installed work will be measured.
- 11.5 Mock-ups, by prior arrangement, may be incorporated into finished work if approved by Consultant only.
- 12 DOCUMENTS ON SITE**
- 12.1 Maintain at job site, one copy of each of the following:
  - .1 Contract Documents including Drawings, Specifications, Addenda, and other modifications to the Contract.
  - .2 'Reviewed' or 'Reviewed as Modified' Shop Drawings.
  - .3 Project Construction and Shop Drawing Schedules.
  - .4 Site Instructions and Change Orders.
  - .5 Field Test Reports.
  - .6 Reports by Authorities having Jurisdiction.
  - .7 Building and other applicable permits.
  - .8 Daily log including:
    - .1 Weather conditions.
    - .2 Excavation conditions.
    - .3 Start and finish date of each Trade Contractor.
    - .4 Erection and removal dates of formwork.
    - .5 Date, quantities and particulars of each concrete pour.
    - .6 Dates and quantities and particulars of roofing and waterproofing work.
    - .7 Visits to the Site by Owner, Consultants, Jurisdictional Authorities, Testing and Inspection companies, and material and equipment supplier representatives.
  - .9 Material Safety Data Sheet pursuant to WHMIS (Occupational Health & Safety Act).
  - .10 As-built drawings recording as-built conditions, instructions, changes for structure, equipment, wiring, plumbing, etc., as called for in Section 01 78 39 and Divisions 22, 23 and 26, prior to being concealed.
  - .11 Copies of applicable codes.
- 12.2 The above material shall be made available to the Consultant at their request.

### **13 BUILDING ENVELOPE**

- 13.1 Requirements specified herein apply to all elements of the exterior building envelope.
- 13.2 Continuity of air barrier/vapour retarder and insulation components is critical and must be maintained at all locations. Where different systems meet, ensure proper interface and continuity between adjacent components by implementing suitable construction sequences and by using compatible materials only.
- 13.3 Maximum air leakage shall be  $0.10 \text{ L}/(\text{sAm}^2)$  when measured with a warm-side relative humidity of 27-55% at  $21^\circ\text{C}$  and a measured air pressure difference of 75Pa.
- 13.4 Anchor exterior cladding components to structure in manner suitable to accommodate structural deflection and creep and to withstand loads from expected temperature gradients. Design anchorage to withstand expected wind loads, positive and negative, in accordance with applicable regulations.
- 13.5 Ensure that air spaces within exterior building components are firestopped in accordance with applicable regulations.
- 13.6 Ensure that air spaces on the outside of vertical air barrier/vapour retarder (walls), window systems, and curtain wall systems are constructed with adequate drainage provisions to the exterior.
- 13.7 Owner may complete a thermographic scan upon completion of the building envelope. Contractor will be responsible to correct identified thermal anomalies.

### **14 DRAINAGE**

- 14.1 Layout and construct work to ensure that positive drainage is provided to floor drains, ditches, site drains and catch basins, as set in their final position, preventing undrained areas and ponding.
- 14.2 Ensure that allowable construction tolerances and structural deflection do not cause ponding of water.
- 14.3 Report to Consultant in writing prior to executing work affected, in case adequate drainage cannot be provided.

END OF SECTION

## **1 GENERAL**

- 1.1 Provide Labour, Products, equipment, services, tools and Supervision to ensure that Work complies with minimum acceptable standards of materials and performance of Work in accordance with codes and standards referenced in the Specification.
- 1.2 Consider contract forms, codes, Specifications, standards, manuals, and installation and application instructions referred to in these specifications to be the latest published editions at the date of submission of the bid unless otherwise stated in the Specifications or otherwise required by the authorities having jurisdiction.

## **2 BY-LAWS, PERMITS, AND FEES**

- 2.1 The Building Code - Ontario Regulation 350/06, including all amendments, shall govern the construction of the Work.
- 2.2 Comply with all By-Laws and regulations of authorities having jurisdiction. These codes and regulations constitute an integral part of the Contract Documents.
- 2.3 Pay for construction damage deposit required by authorities having jurisdiction.
- 2.4 Where permits, licences, and inspection fees are required by authorities having jurisdiction for specific trade functions, they shall be obtained by particular subtrade responsible for that work.
- 2.5 Arrange for inspection, testing of Work and acceptance required by the authorities having jurisdiction. Be responsible for necessary preparations, provisions and pay all costs.
- 2.6 Be responsible for ensuring that no work is undertaken which is conditional on permits, approvals, reviews, licences, fees, until all applicable conditions are met. No time extension will be allowed for delay in obtaining necessary permits..
- 2.7 Obtain permit required to work on Municipal rights of way. Obtain damage deposits for sidewalks, roads and services work, as applicable.
- 2.8 Give notice of completion of project prior to occupancy, as required by applicable legislation.

## **3 EXISTING PUBLIC SERVICE LINES**

- 3.1 Where existing public services are indicated to be removed and/or relocated, perform Work in compliance with authorities having jurisdiction.
- 3.2 Make good public roads, walkways and curbs soiled or damaged due to construction to the requirements of local authorities.

#### **4 CODES**

- 4.1 Reference is made to standards in the specifications to establish minimum acceptable standards of materials, products and workmanship. Ensure that materials, products and workmanship meet or exceed requirements of the reference standards specified.
- 4.2 In the event of conflict between documents specified herein, execute the Work in accordance with the most stringent requirements.

#### **5 STANDARDS**

- 5.1 Where a material or product is specified in conjunction with a referenced standard, do not supply the material or product if it does not meet the requirements of the standard. Supply another specified material or product, or an acceptable material or product of other approved manufacture which does meet the requirements of the standard, at no additional cost to the Owner.
- 5.2 Where no standard is referred to, provide materials, products and workmanship which meet requirements of the applicable standards of the Canadian Standards Association, Canadian General Standards Board, Standards Council of Canada, Ontario Provincial standard specifications (OPSS), Ontario Provincial Standard Drawings (OPSD) and the applicable building code. References to "Measurement for Payment" and "Basis of payment" in OPSS standard documents are not applicable to this Contract.
- 5.3 If there is question as to whether a material, product or system is in conformance with applicable standards, the Consultant reserves the right to have such materials, products or systems tested to prove or disprove conformance. The cost for such testing will be paid by the Owner in the event of conformance with contract Documents or by the Contractor in the event of non-conformance.
- 5.4 Where application, installation and workmanship standards are cited, it is intended that referenced standards form the basis for minimum requirements of the specified item and specifications supplement the standards unless specified otherwise.
- 5.5 Matters may be dealt with in part by these specifications which are also dealt with, under the same or similar headings in cited standard. It is not intended that these specifications take the place of the standards but supplement them, unless specified otherwise.
- 5.6 Where reference is made to manufacturer's directions, instructions or specifications they shall include full information on storing, handling, preparing, mixing, installing, erecting, applying, or other matters concerning the materials pertinent to their use and their relationship to materials with which they are incorporated.

5.7 Where standards, specifications, associations, and regulatory bodies are listed in the Specifications by their abbreviated designations. These are but not limited to the following:

AA	The Aluminum Association
AAMA	Architectural Aluminum Manufacturers Association
AASHTO	American Association of State Highway and Transportation Officials.
ACI	American Concrete Institute
AFBMA	Anti-Friction Bearing Manufacturer's Association
AIEE	American Institute of Electrical Engineers
AISI	American Iron and Steel Institute
AMCA	Air Movement and Control Association
AMEU	Association of Municipal Electric Utilities
ANSI	American National Standards Institute
ARI	Air-Conditioning and Refrigeration Institute
ASA	American Standards Association
ASHRAE	American Society of Heating, Refrigeration and Air Conditioning Engineers
ASME	American Society of Mechanical Engineers
ASTM	American Society of Testing and Materials AWMAC Architectural Woodwork Manufacturers Association of Canada
AWWA	American Water Works Association
CEMA	Canadian Electrical Manufacturer's Association
CGA	Canadian Gas Association
CGSB	Canadian General Standards Board
CISC	Canadian Institute of Steel Construction
CMHC	Canadian Mortgage and Housing Corporation
CMPA	Canadian Paint Manufacturers Association
COFI	Council of Forest Industries of British Columbia
CRCA	Canadian Roofing Contractors Association CSA Canadian Standards Association
CSSBI	Canadian Sheet Steel Building Institute
CWB	Canadian Welding Bureau
CWC	Canadian Wood Council
EEMAC	Electrical and Electronic Manufacturers Association Canada
FM	Factory Mutual
IEEE	Institute of Electrical and Electronic Engineers
MFMA	Maple Flooring Manufacturers Association
MIL	Military Standards
MSS	Manufacturer's Standardization Society
MTO	Ministry of Transportation Ontario
NAAMM	National Association of Architectural Metal Manufacturers
NFPA	National Fire Protection Association
NEMA	National Electrical Manufacturer's Association (U.S.A.)

NLGA	National Lumber Grades Authority
NRC	National Research Council of Canada
OCBA	Ontario Concrete Block Association
OHESC	Ontario Hydro Electrical Safety Code
OPSS	Ontario Provincial Standard Specification
PEI	Porcelain Enamel Institute
PDI	Plumbing Drainage Institute
PHA	Public Health Act
SMACNA	Sheet Metal and Air Conditioning Contractors National Association
SSPC	Steel Structures Painting Council
TEMA	Tubular Exchange Manufacturer's Association
TSSA	Technical Standards and Safety Authority
TTMAC	Terrazzo, Tile and Marble Association of Canada
UL	Underwriters Laboratories Inc. (U.S.) ULC Underwriters Laboratories of Canada

## **6 FIRE RATINGS, ASSEMBLIES AND SEPARATIONS**

- 6.1 Where a material, component, assembly, or separation is required to be fire rated, the fire rating shall be as determined or listed by one of the following testing authorities acceptable to the authorities having jurisdiction:
- .1 Underwriters' Laboratories of Canada.
  - .2 Underwriters' Laboratories Inc.
  - .3 Factory Mutual Laboratories.
  - .4 The National Research Council of Canada.
  - .5 The National Board of Fire Underwriters.
  - .6 Intertek Testing Services.
- 6.2 Where reference is made to only one testing authority an equivalent fire rating as determined or listed by another of the aforementioned testing authorities is acceptable if approved by authorities having jurisdiction. Obtain and submit such approval of authorities, in writing when requesting acceptance of a proposed equivalent rating or test design.
- 6.3 Fire rated door assemblies shall include doors, frame, anchors, and hardware and shall bear label of fire rating authority showing opening classification and rating.
- 6.4 Material having a fire hazard classification shall be applied or installed in accordance with fire rating authorities printed instructions.

- 6.5 Fire rated assemblies shall be constructed in accordance with applicable fire test report information issued by fire rating authority. Deviation from fire test report will not be allowed.
- 6.6 Construct fire separations as continuous, uninterrupted elements except for permitted openings. Extend fire rated walls and partitions from floor to underside of structural deck above.
- 6.7 Fire separations may be pierced by openings for electrical and similar service outlets provided such boxes are non-combustible and are tightly fitted and sealed with a ULC approved sealant for the assembly being sealed.
- 6.8 Construction that abuts on or is supported by a non-combustible fire separation shall be constructed so that its collapse under fire conditions will not cause the collapse of the fire separation.
- 6.9 Do not use combustible members, fastenings, attachments and similar items to anchor electrical, mechanical or other fixtures to fire separations.
- 6.10 At penetration through fire rated walls, ceilings or floors, completely seal voids with ULC approved firestopping material; full thickness of the construction element. In locations that require a smoke seal, provide appropriate ULC approved system installed in accordance with the manufacturer's recommendations.

## **7 DRAWINGS REQUIRED BY AUTHORITIES**

- 7.1 Supply copies of detail drawings for various building components if requested by the Municipal Building Departments, Provincial Agencies and the Local Fire Department.

END OF SECTION

## **1 TEMPORARY CONTROLS**

- 1.1 Hoarding and barriers:
- .1 Provide temporary enclosures as required to protect the building in its entirety or in its parts, against the elements, to maintain environmental conditions required for work within the enclosure, and to prevent damage to materials stored within, all as required by the Construction Safety Act and other jurisdictional authorities.
  - .2 Reposition temporary enclosures as required due to different areas of work and schedule.
- 1.2 Hoarding shall be provided to secure the work areas, restrict non-authorized personnel from the work areas, protect the Contractor's property and the Ontario Health & Safety Act.
- 1.3 Prevent unauthorized entry to the Site. Barricade, guard or lock access points to the satisfaction of the Consultant and post "NO TRESPASSING" signs.
- 1.4 Provide barriers and covered walkways required by governing authorities for public rights-of-way and for public access to buildings. Snow fencing is not allowed as protection for sidewalk.
- 1.5 Install signs for movement of people around Work Site as required and directed by the Consultant.
- 1.6 Provide secure, rigid guide rails and barricades around deep excavations, open edges of floors and roofs as required for protection of Work, workers, and the public.
- 1.7 Remove hoarding, barriers, building enclosures, guide rails and barricades upon Contract Completion unless otherwise noted on the Contract Drawings or as directed by the Consultant.

## **2 SERVICE AND UTILITY SYSTEMS**

- 2.1 Consult with utility companies and other authorities having jurisdiction to ascertain the locations of existing services on or adjacent to site.
- 2.2 Information as to the location of existing services, if shown on the Drawings, does not relieve the Contractor of his responsibility to determine the exact number and location of existing services.
- 2.3 Give proper notices for new services as may be required. Make arrangements with authorities and utilities for service connections required.
- 2.4 Pay any charges levied by utilities or authorities for work carried out by them in connection with this Contract, unless specified otherwise.



2.5 Operate and maintain all utility systems affected by work of this Contract, until the building or specific portions thereof have been accepted by the Owner.

2.6 Report existing unknown services encountered during excavation to Consultant for instructions; cut back and cap or plug unused services. Be responsible for the protection of all active services encountered and for repair of such services if damaged.

### **3 SCAFFOLDING, HOISTS AND CRANES**

3.1 Select, operate, and maintain scaffolding, hoisting equipment and cranes as may be required in accordance the Ontario Health & Safety Act & Regulations for Construction Projects.

3.2 Do not erect or operate equipment that will endanger existing structures, local municipalities hydro installations, or traffic signals.

3.3 Design and construct scaffolding in accordance with CAN/CSA S269.2-M.

### **4 TEMPORARY WORKS**

4.1 Installation and Removal: Provide temporary utilities, facilities and controls in order to execute the Work expeditiously. Remove from Site all such Work after use.

4.2 Arrange for connections with appropriate utility company and pay all costs for installation, maintenance and removal.

4.3 Arrange for connections with Owner and pay all costs for installation, maintenance and removal.

4.4 Pay all costs for temporary works consumed prior to Contract Completion.

4.5 Temporary Power and Lighting Systems:

.1 Supply, install and maintain electrical power and necessary electrical equipment including overhead and underground feeders, transformers, motors, starters, protective devices and equipment. Connections will be made available to any part of the Work within distance of a 30 m extension.

.2 Provide temporary lighting inside and outside structure of adequate intensity to illuminate construction activities. Provide temporary pedestrian lighting for sidewalk areas affected by the Work.

.3 Supply and install the type and quantity of minimum lighting equipment in each location to ensure adequate, continual illumination 24 hours per day, 7 days per week for the following:

.1 Emergency evacuation, safety and security throughout the Project at intensity levels required by jurisdictional authorities.

- .2 General lighting for performance of the Work throughout the Project, evenly distributed, and at intensities to ensure that proper installations and applications are achieved.
  - .3 Performance of finishing trades in area as required evenly distributed, and of an intensity of at least 50 Lux.
  - .4 In locations approved by the Consultant. Install and support the electrical plant, distribution and temporary lighting systems including service equipment and local hydro authority meter energized by the local hydro circuits. Installations shall be approved by the Consultant and shall be carried out in a neat manner to avoid interference with the application of finish material and to facilitate removal when the installed permanent lighting system is in operation.
  - .5 Make all necessary arrangements for and pay all costs for a temporary electrical service of sufficient capacity to supply temporary lighting, operation of power tools, cranes and equipment for all construction, implementation, and inspection and testing purposes. Supply and install necessary temporary cables and other electrical equipment and make all temporary connections as required.
  - .6 Temporary power distribution wiring shall comply with Ontario Hydro Electrical Safety Code. Obtain inspection certificates for temporary electrical work.
  - .7 Maintain the lighting systems in operation during the life of the Contract. Replace burned or missing lamps immediately.
  - .8 Upon Contract Completion, remove electrical plant and temporary lighting from the Site.
- 4.6 Water Supply:
- .1 Provide and pay for a continuous supply of potable water for construction use. Provide as a minimum one water connection on each floor level.
  - .2 Provide and maintain all temporary lines, extensions and hoses as required. Remove all temporary connections and lines on completion of the Work and make good any damage.
- 4.7 Temporary Heating:
- .1 Provide temporary heating required during construction period, including attendance, maintenance and fuel.
  - .2 Construction heaters used inside buildings must be vented to the outside or be flame less type. Solid fuel salamanders are not permitted.
  - .3 Maintain temperatures of minimum 10°C in areas where construction is in progress unless otherwise indicated in the Contract Documents. Protect exposed and adjacent services from freezing. Repair at no cost to the Owner any such services, buildings or other utilities disrupted by freezing.

- .4 Ventilate heated areas and keep structures free from exhaust combustion gases.
- .5 The permanent heating system of the building or portions thereof may be used when available only upon written permission by Consultant.
- 4.8 Temporary Telephone and facsimile: Provide and pay for separate telephones and facsimile services, for local call only, as required for own use and use of the Consultant and Owner. Long distance call shall be paid by party making call.
- 4.9 Sanitary Facilities: Provide sanitary facilities in accordance with occupational health and safety requirements in the place of the Work. Use of Owner's existing sanitary facilities or new sanitary facilities is not allowed.
- 5 PROTECTION**
- 5.1 Protection of Public Area: Protect surrounding private and public property from damage during performance of the Work.
- 5.2 Protection of Building Finishes and Equipment:
  - .1 Provide protection for existing structure, finished and partially finished building finishes, waterproofing systems, and equipment during performance of the Work.
  - .2 Cover Owner's equipment and plant within the Site with 6 mil PVC sheet, or equal, taped to make it dust-tight. Equipment and existing work moved or altered to facilitate construction, movement of Products or equipment shall be stored, protected with dust-tight covers and subsequently returned to its original location.
  - .3 Obtain approval from the Consultant prior to the installation of temporary supporting devices into existing roof, ceiling, or wall members for the erecting of equipment or machinery. Repair roof, ceiling, and wall members used for this purpose to the satisfaction of the Consultant.
  - .4 Provide necessary screens, covers and hoarding as required.
  - .5 Any Products or equipment damaged while carrying out the Work shall be restored with new Products or equipment matching the original equipment. Damage shall include harm resulting from all construction work, such as falling objects, wheel and foot traffic, failure to remove debris, operation of machinery and equipment, and scaffolding and hoisting operations.
- 5.3 Protection of Off-Site Structures, Surfaces and Trees: Accept all cost and responsibility for any injury or damage to existing structures, surfaces and trees on the City's property which may be caused by the Contractor's workforce and material suppliers.

5.4 Fire Protection:

- .1 Take precautions to prevent fires. Provide and maintain temporary fire protection equipment of a type appropriate to the hazard anticipated in accordance with authorities having jurisdiction, governing codes, regulations, by-laws and to the satisfaction of the Consultant and insurance authorities.
- .2 Excessive storage of flammable liquids and other hazardous materials is not allowed on Site. Flammable liquids must be handled in approved containers. Remove combustible wastes frequently.
- .3 Inspect temporary wiring, drop cords, extension cables for defective insulation or connections frequently.
- .4 Open burning of rubbish is not permitted on the Site.
- .5 Handle, transport, store, use and dispose of gasoline, benzine or other flammable materials with good and safe practice as required by authorities having jurisdiction.
- .6 Provide fire extinguishers of the non-freezing chemical type in each temporary building, enclosure and trailer. Use only fire-proofed tarpaulins.
- .7 A fire watch shall be required for each of the following activities regardless of the number, duration or size of the activity in operation:
  - .1 any open flame activities(e.g., soldering and welding);
  - .2 shutdown of fire detection system;
  - .3 shutdown of sprinkler system.

5.5 Maintain adequate cover over services as required by Utility Authorities.

5.6 Dust protection and migration of dust to other areas of property in accordance with Section 02 40 00.

**6 TEMPORARY BUILDINGS**

6.1 General Contractor shall provide their own site trailer/office.

6.2 For all trailers and temporary buildings, provide wood stairs, platform and boardwalk, painted and repainted as required with non-skid abrasive paint.

6.3 Do not locate any buildings, structures or equipment in a manner that interferes with surveys along the control line and reference line tangents.

6.4 Remove temporary buildings upon Contract Completion. Restore area(s) to match the existing surrounding area.

## **7 PEST CONTROL**

- 7.1 Be responsible to provide control measures, restraining procedures, and treatments to prevent infestation and spread of insects, rodents and other pests deemed to be present at Site and/or noticed during course of the Work. Carry out fumigation, pest control procedure, and posting of warning signs, notices including contents of such notices in accordance with requirements of Pesticides Act and any other authorities having jurisdictions. Pesticides used shall be in accordance with Canada Pest Control Products Act, and provincial and municipal regulations.

## **8 FIRST-AID FACILITIES**

- 8.1 Provide site equipment and medical facilities necessary to supply first-aid service to injured personnel in accordance with regulations of the Workmen's Compensation Act. Maintain facilities for duration of Contract.

## **9 USE OF NEW PERMANENT SERVICE & EQUIPMENT**

- 9.1 Do not use any new permanent service or equipment without Owner's written approval.
- 9.2 Where permission is granted to use permanent services and equipment provide competent persons to operate services and equipment; inspect frequently and maintain facilities in proper operating condition at all times.
- 9.3 Permanent services and equipment shall be turned over to Owner in 'as new' and perfect operating condition.
- 9.4 Use of permanent systems and equipment as temporary facilities shall not affect the warranty conditions and warranty period for such systems and equipment. Make due allowance to ensure that Owner will receive full benefits of equipment manufacturers warranty after project takeover.

## **10 PROJECT IDENTIFICATION**

- 10.1 If required, obtain approvals from jurisdictional authorities for temporary signs.
- 10.2 Do not display signs without the Consultant's and Owners written consent.
- 10.3 Maintain signs in good condition for the duration of Contract.
- 10.4 Allow for erection of Owner's Project Identification Sign in accordance with details provided by Owner.

## **11 SITE MAINTENANCE**

- 11.1 Maintain the Site and adjacent premises in a clean and orderly condition, free from debris and other objectionable matter. Immediately remove rubbish and surplus Products, equipment and structures from the Site. If the Site is not cleaned (within 48 hours after the Contractor has been instructed to do so), the Consultant may clean the Site and retain the cost from monies due, or to become due, to the Contractor.
- 11.2 When the Work is substantially performed, remove surplus Products, tools, construction machinery and equipment not required for the performance of the remaining Work.

## **12 SITE STORAGE AND OVER LOADING**

- 12.1 Confine the Work and operations of employees to limits indicated by the Contract Documents. Do not unreasonably encumber the Site with Products.
- 12.2 Products shall be stored only in areas designated or approved by the Consultant, and shall not be left lying on streets, sidewalks, boulevards or elsewhere within public view. Products which the Consultant may permit to be stored elsewhere than in the Contractor's storage areas shall be neatly stacked or otherwise disposed and shall be so maintained.
- 12.3 Fabrication shops shall not be set up within the structure except as directed by or with the permission of the Consultant.
- 12.4 Do not load or permit to be loaded any part of the Work with a weight or force that it is not calculated to bear safely. Be solely responsible and liable for damages resulting from violation of this requirement. Provide temporary supports as strong as permanent support.
- 12.5 Do not cut, drill or sleeve load bearing members unless shown on drawings or otherwise approved by the Consultant in writing for each location.
- 12.6 Site storage and loading requirements to be in accordance with the Ontario Occupational Health and Safety Act and Regulations for Construction Projects.

## **13 PUBLIC CONVENIENCE AND SAFETY**

- 13.1 Maintain sidewalks at and adjacent to the Site in a safe condition throughout the Contract. Promptly remove ice and snow.
- 13.2 Keep haul routes free at all times from Products spilled on highway or street surfaces and clean highways and streets of deposits due to performance of the Work to the satisfaction of the Consultant and the highway and street authorities. Clean highways and streets within 24 hours of Consultant's instruction.

13.3 The Consultant may inspect haul routes, the Site and adjacent premises daily and may halt operations, withhold payment or carry out such additional operations as necessary, deducting the cost from monies due, or to become due, to the Contractor.

#### **14 ACCESS AND EGRESS TO SITE**

14.1 Where construction requirements demand, construct access roads capable of withstanding construction equipment and haul traffic. Maintain access roads in good condition at all times. Remove access roads prior to completion of the Work unless otherwise noted and restore area as shown on the Contract Drawings.

#### **15 PUBLIC TRAFFIC FLOW**

15.1 Provide and maintain flag persons, Police Officers, traffic signals, barricades and illumination as required by Authorities having jurisdiction and/or as necessary to perform the Work and protect the public.

#### **16 PUBLIC UTILITIES AND SERVICES**

16.1 Verify limitations imposed on project work by presence of utilities and services, and ensure no damage occurs to them.

16.2 Notify service authorities concerned so that they protect, remove, relocate, or discontinue them, as they may require.

16.3 Make arrangements and pay for connection charges for services required for project work.

16.4 Locate poles, pipes, conduit, wires, fill pipes, vents, regulators, meters, and sanitary services work in inconspicuous locations. If not shown on Drawings, verify location of service work with Consultant before commencing installation.

#### **17 ROADS, CURBS, GUTTERS, AND WALKS**

17.1 Include all curb cuts and making good of existing curbs, walks and paving on Municipal property to provide fully paved and finished approaches to requirements of authorities having jurisdiction.

#### **18 CONSTRUCTION PARKING**

18.1 Parking may be permitted on Site provided it does not disrupt the performance of Work, Site safety or the movement of vehicular or pedestrian traffic and is acceptable to the Consultant.

#### **19 SITE VISITORS**

19.1 During the progress of the Work, afford access to visitors duly authorized by the Consultant and facilitate inspections or tests they may desire to make. Record site visitors in log book maintained on site.

19.2 Ensure Site visitors wear appropriate safety apparel.

## **20 EROSION AND SEDIMENTATION CONTROL**

20.1 Control drainage on site to prevent flooding, erosion and run-off onto adjacent properties as a result of construction operations.

20.2 Dispose of water containing silt in suspension in accordance with requirements of jurisdictional authorities.

20.3 Conform to sedimentation and erosion control measures as indicated on Civil Engineering drawings and requirements of the conservation and/or municipal authority having jurisdiction for the duration of the Work. Provide and maintain until completion of work or until directed by Consultant to be removed, sediment control devices at catch basins, drainage courses and at other locations on site as directed. Comply with requirements of the local Conservation Authority.

20.4 Provide storm drain inlet protection consisting of a sediment control barrier or an excavated ponding area around storm drain inlet or curb inlet; add bracing where necessary to withstand high flow volumes and depth. Inspect inlet protection after each rainfall and repair damage. Sweep up accumulated sediment and dispose of in a controlled area. Remove inlet protection after area has been stabilized with permanent vegetation.

## **21 TEMPORARY DRAINAGE AND DEWATERING**

21.1 Drainage lines and gutters shall be kept open at all times. No flow of water shall be directed across or over pavements except through pipes or properly constructed troughs. Keep all portions of Work properly and efficiently drained during construction and until completion. Be responsible for all disturbances, dirt and damage which may be caused by or result from water backing up or flowing over, through, from or along any part of Work, or due to operations which may cause water to flow elsewhere.

21.2 Keep trenches and other excavations free of water at all times. Employ adequate means to remove water in a manner that will prevent loss of soil, and maintain the stability of excavation.

21.3 Dispose of such water in a manner that will not be dangerous to public health, private property or to any portion of Work completed or under construction, nor which causes an impediment to the use of streets by the public.

21.4 Drainage of trenches or other excavation through newly laid storm drainage pipe will be allowed only with the express permission of the authority having jurisdiction.

21.5 When drainage is directed to existing catch basins, regularly inspect and clean such catch basins of debris and sediment.



**22 SNOW REMOVAL**

- 22.1 Allow no accumulation of ice and snow on Site, and on roof deck when roofing operations are scheduled to take place.
- 22.2 Remove snow from access road, Site circulation paths and elsewhere as required to permit access to Work, parking and uninterrupted construction progress.

**23 POLLUTION (DUST, DEBRIS, AND NOISE) CONTROL**

- 23.1 Cover or wet down dry materials and rubbish to prevent blowing dust and debris. Provide dust control for temporary roads.
- 23.2 Keep premises free of waste material.
- 23.3 Arrange and pay for removal of all waste generated by the work in manner acceptable to authorities having jurisdiction.
- 23.4 Limit noise levels in accordance with requirements of authorities having jurisdiction.
- 23.5 Maintain temporary erosion and pollution control features installed under this contract.
- 23.6 Control emissions from equipment and plant to local authorities emission requirements.
- 23.7 Prevent abrasive-blasting and other extraneous materials from contaminating air beyond application area, by providing temporary enclosures.

**24 TREE PROTECTION**

- 24.1 Refer to Tree Protection Zone specification as appended.

END OF SECTION

## 1 **SPECIFIED PRODUCTS**

- 1.1 Work of this Contract is based on Products specified by:
- .1 Manufacturer's catalogued trade names and/or;
  - .2 References to standards (i.e. CAN, CGSB, CSA, ASTM) or;
  - .3 Prescriptive Specifications or;
  - .4 Performance Specifications.
- 1.2 When one or more manufacturer's trade name is specified for a Product, any one of the specified Products will be acceptable. Products by other manufacturers are subject to the Consultant's acceptance as an equivalent substitution in accordance with the specified requirements of substitutions.
- 1.3 When more than one manufacturer's catalogued trade name Product is specified along with a referenced standard, any one of the specified Products will be acceptable on condition the Product complies with the referenced standard.
- 1.4 When a Product is specified by reference to a standard only, the Contractor may select any Product that meets or exceeds the specified standard for the intended purpose. The onus shall be on the Contractor to establish that such Products meet the reference standard requirements. Products exceeding minimum requirements established by reference standards will be accepted for the Work if such Products are compatible with the Work with which they are incorporated.
- 1.5 When a Product is specified by prescriptive or performance Specification, any Product meeting or exceeding the Specification will be accepted.
- 1.6 When a Product is specified by reference to a standard or by prescriptive or performance Specification, upon request of the Consultant, obtain from the manufacturer, an independent testing laboratory report showing that the Product meets or exceeds the specified requirements.
- 1.7 Unless otherwise indicated in the Specifications, maintain uniformity of manufacture for any particular or like item throughout the Work.

## 2 **SUBSTITUTIONS**

- 2.1 Requests for substitutions will not be accepted prior to the Notification of Award. Substitutions will be considered by the Consultant provided that:
- .1 The proposed substitutions have been investigated and complete data are submitted which clearly includes highlighting all aspects that meet the specifications. Consultant will only review data submitted. Incomplete data will be grounds for non-acceptance.

- .2 Data relating to changes in the Contract Schedule, if any, and relation to other Work have been submitted.
  - .3 Same warranty is given for the substitution as for the original Product specified.
  - .4 All claims are waived for additional costs related to the substitution which may subsequently arise.
  - .5 Installation of the accepted substitution is co-ordinated into the Work and that full responsibility is assumed when substitutions affect other work. Make any necessary changes required to complete the Work. Revisions to the drawings for incorporation of the substitutions shall be made by the Consultant and all costs associated with the revisions shall be borne by the Contractor.
- 2.2 Substitutions to methods or process described in the Specifications or drawings, may be proposed for the consideration of the Consultant. Ensure that such substitutions are in accordance with the following requirements:
- .1 Time spent by the Consultant in evaluating the substitution shall not be the basis for a claim by the Contractor for extensions to the Contract Time.
  - .2 Clearly indicate how the proposed substitutions would be advantageous to the Owner or in the opinion of the Contractor would improve the operation of the installation and schedule of events.
  - .3 Be responsible for substitutions to methods or processes concerning such Work and ensure that the warranty covering all parts of the Work will not be affected.
  - .4 The cost of all changes in the work of Other Contractors, necessitated by the substituted methods or processes, if accepted, is borne by the Contractor.
  - .5 The substituted methods or processes fit into space allotted for the specified methods or processes. Revisions to the drawings for incorporation of the substitutions shall be made by the Consultant and all costs associated with the revisions shall be borne by the Contractor.
  - .6 Also list conformance to TDSB Substitution requirements.
- 2.3 Substitutions will not be considered if:
- .1 They are indicated or implied on shop drawings or Product data without formal request.
  - .2 Acceptance will require substantial revision of the Specifications and Drawings.
- 2.4 Do not substitute Products or methods or processes into the Work unless such substitutions have been specifically approved for the Work by the Consultant.

- 2.5 Approved substituted Products shall be subject to the Consultant's inspection and testing procedures. Approved substituted Products shall only be installed after receipt of the Consultant's written approval.
- 2.6 The Contract Price will be adjusted accordingly to any and all credits arising from the substitutions mentioned above.

### **3 APPROVAL OF PRODUCTS AND INSTALLATION METHODS**

- 3.1 Wherever in the Specifications it is specified that Products and installation methods shall meet approval of Authorities having Jurisdiction, underwriters, the Consultant, or others, such approval shall be in writing.

### **4 PRODUCT DELIVERY CONTROL**

- 4.1 It is the responsibility of the Contractor to ensure that the supplier or distributor of materials specified or alternatives accepted, which he intends to use, has materials on the site when required. The Contractor shall obtain confirmed delivery dates from the supplier.
- 4.2 The Contractor shall contact the Consultant immediately upon receipt of information indicating that any material or item, will not be available on time, in accordance with the original schedule, and similarly it shall be the responsibility of all subcontractors and suppliers to so inform the Contractor.
- 4.3 The Consultant reserves the right to receive from the Contractor at any time, upon request, copies of actual purchase or work orders of any material or products to be supplied for the work.
- 4.4 If materials and products have not been placed on order, the Consultant may instruct such items to be placed on order, if direct communication in writing from the manufacturer or prime suppliers is not available indicating that delivery of said material will be made in sufficient time for the orderly completion of the Work.
- 4.5 The Consultant's review of purchase orders or other related documentation shall in no way release the Contractor, or his subcontractors and suppliers from their responsibility for ensuring the timely ordering of all materials and items required, including the necessary expediting, to complete the work as scheduled in accordance with the Contract Documents.
- 4.6 In the event of failure to notify the Consultant at commencement of Work and should it subsequently appear that Work may be delayed for such reason, the Consultant reserves the right to direct the Contractor to take the following measures at no increase in Contract Price:
- .1 Substitute more readily available Products of similar or better quality and character, or

- .2 Temporarily install another Product until such time as the specified Product becomes available, at which time the temporarily installed product shall be removed and the specified Product installed.

## **5 TRADEMARKS AND LABELS**

- 5.1 Permanent labels, trademarks and nameplates on Products are not acceptable in the finished Work, except where required by authorities having jurisdiction, for operating instructions, or when located in service rooms.
- 5.2 Remove trademarks and labels by grinding, if necessary, painting out where the particular surface is being painted, or if on plated parts, replace with new plain plated or non-ferrous metal parts.

## **6 DELIVERY, STORAGE, HANDLING AND PROTECTION**

- 6.1 Be responsible for handling and delivery of Products. Protect Products from damage during handling, storage and installation. Deliver store and handle items in accordance with manufacturer's instructions and as specified. Be responsible for all costs of delivery, loading and off-loading, and for transportation back to its origin for correction, if required, due to damage or defect. Reject materials and Products delivered to the Site which are damaged.
- 6.2 Manufacture, pack, ship, deliver, and handle Products so that no damage occurs to structural qualities and finish appearance, nor in any other way which is detrimental to their function and appearance.
- 6.3 Ensure that Products, while transported, are not exposed to an environment which would increase their moisture content beyond the maximum specified.
- 6.4 Organize delivery of materials, Products and equipment to, and removal of debris and equipment from, the site and surrounding property.
- 6.5 Schedule early delivery of Products to enable Work to be executed without delay. Before delivery, arrange for receiving at the Place of the Work.
- 6.6 Coordinate mechanical and electrical equipment and apparatus deliveries with the manufacturer's and suppliers such that equipment and apparatus is delivered to the site when it is required, or so that it can be stored within the building and protected from the elements.
- 6.7 Shop assemble work for delivery to site in size easily handled and to ensure passage through building openings.
- 6.8 Deliver packaged Products, in original unopened wrapping or containers, with manufacturer's seals and labels intact.
- 6.9 Label packaged products to describe contents, quantity, and other information as specified.

- 6.10 Labels attesting that materials conform to specified reference standards will be acceptable as verification that contents meet specified requirements. In the absence of labels, submit affidavits to validate conformance of Product to reference standards, as requested by the Consultant.
- 6.11 Label fire-rated Products to indicate Underwriters' Laboratories approval.
- 6.12 Handle and store materials and products in such a manner that no damage is caused to the materials and products, the Work, the site and surrounding property.
- 6.13 Do not obstruct or disrupt local traffic flow during construction period.
- 6.14 Allocate an area within the limits of the Work acceptable to the Owner for storage of Products brought to the site by all trades. Keep storage area tidy at all times and do not use other parts of the property for storage. Arrange and pay for off-site storage when required.
- 6.15 Locate products on site in a manner to cause minimal interference with the Work and building activities.
- 6.16 Store Products off the ground, in a manner to prevent damage, adulteration, deterioration and soiling to the Products, other building components, assemblies, other products, the structure, the site and surrounding property, and in accordance with manufacturer's instructions when applicable.
- 6.17 Store packaged or bundled Products in original and undamaged condition complete with written application instructions. Keep manufacturer's seals and labels intact. Do not remove from packaging or bundling until required in the Work.
- 6.18 Do not place or store materials and Products in corridors, public areas, streets, lanes, passageways or similar locations.
- 6.19 Store Products so as not to create any overloading conditions to any part of the building, structure, falsework, form work and scaffolding.
- 6.20 Store Products subject to damage from weather in weatherproof enclosures.
- 6.21 Store cementitious Products clear of earth or concrete floors, and away from walls.
- 6.22 Keep sand, when used for grout or mortar materials, clean and dry. Store sand on wooden platforms and cover with waterproof tarpaulins during inclement weather.
- 6.23 Store sheet materials and lumber on flat, solid supports and keep clear of ground. Slope to shed moisture.
- 6.24 Store and handle flammable liquids and other hazardous materials in approved safety containers and as otherwise prescribed by safety authorities. Store no flammable liquids or other hazardous material in bulk within the Work.

- 6.25 Store and mix paints in a heated and ventilated room or area assigned for this purpose. Keep this room or area locked when unattended. Remove oily rags and other combustible debris from the Place of the Work daily. Take every precaution necessary to prevent spontaneous combustion.
- 6.26 Protect prefinished metal surfaces by protective coatings or wrappings until time of final cleanup specified in Section 01 74 00. Protection shall be easily removable under work of Section 01 74 00 without damage to finishes. Do not permit strippable tape or coatings to become baked on surfaces which they protect.
- 6.27 Touch-up damaged factory finished surfaces to Consultant's satisfaction. Use primer and paint to match original.
- 6.28 Protect glass and other finishes against heat, slag and weld splatter by provision on adequate shielding. Do not apply Visible markings to surfaces exposed to view in finished state or that receive transparent finishes.
- 6.29 Protect surfaces of completed work exposed to view from staining, disfigurement and all other damage by restriction of access or by use of physical means suitable of the material and surface location.
- 6.30 Adequately protect trowelled concrete floors from damage. Take special measure when moving heavy loads or equipment on them.
- 6.31 Keep finished concrete floors free from oils, grease or other material likely to damage or discolour them or affect bond of applied finishes. Once building is enclosed, keep floors as dry as possible after curing.
- 6.32 Protect finished flooring from pedestrian traffic with reinforced kraft paper as a minimum, secured in place and with joints sealed by reinforced pressure sensitive tape. Maintain protection in place until contract completion.
- 6.33 Protect finished flooring from continuing construction work and delivery of products with plywood panels of minimum 6 mm thickness with joints between panels sealed with reinforced pressure sensitive tape. Maintain protection in place until work and deliveries are complete.
- 6.34 Make good or replace damaged materials to the satisfaction of the Consultant.
- 6.35 Hazardous Materials Information:
- .1 Comply with requirements of Workplace Hazardous Materials Information System (WHMIS) regarding use, handling, storage, and disposal of hazardous materials; and regarding labelling and provision of material safety data sheets (MSDS) in accordance with jurisdictional authorities.
- .2 Deliver copies of Material Safety Data Sheets (MSDS) to the Consultant on all Products intended for use in the Work and designated as a "controlled product."

## **7 MANUFACTURER'S INSTRUCTIONS**

- 7.1 Unless otherwise indicated in the Specifications, fabricate, install, apply, connect, install, erect, use, clean, and condition Products in accordance with manufacturer's instructions except where more stringent requirements are specified. Do not rely on labels or enclosures provided with Products. Obtain written instructions directly from manufacturers.
- 7.2 Notify the Consultant in writing, of conflicts between the Specifications and manufacturer's instructions, so that the Consultant may establish the course of action. If requested, make a copy of those instructions available at the site.
- 7.3 In cases of improper installation or erection of Products, due to failure in complying with these requirements, the Consultant may direct removal and re-installation at no increase in Contract Price.

## **8 WORKMANSHIP**

- 8.1 Do not employ any unfit person or anyone unskilled in their required duties. The Consultant reserves the right to require the dismissal from the Place of the Work, workers deemed incompetent, careless, insubordinate or otherwise objectionable.
- 8.2 Decisions as to the quality or fitness of workmanship in cases of dispute rest solely with the Consultant, whose decision is final.
- 8.3 Give particular attention to finished dimensions and elevations of the Work. Make finished Work fit indicated spaces accurately. Make finished Work flush, plumb, true to lines and levels and accurate in all respects.
- 8.4 In finished areas, conceal pipes, ducts, conduit and wiring in floors, walls, ceilings, chases, or behind furring except where indicated otherwise.
- 8.5 Ensure that service poles, fill-pipes, vents, regulators, meters and similar service installations are located in inconspicuous locations. If not indicated on drawings, verify location of service installations with Consultant prior to commencing installation.
- 8.6 Ensure that integrity of fire separations is maintained where they are penetrated.
- 8.7 Finish access panels and doors to match adjacent wall and/or ceiling finish unless otherwise specified or indicated.
- 8.8 Keep surfaces, on which finished materials will be applied, free from grease, oil, and other contamination which would be detrimental in any way to the application of finish materials.



- 8.9 Enforce fire prevention methods at site. Do not permit fires, open flame heating devices or accumulation of debris. Use flammable materials only if all safety precautions are taken. Provide and maintain in working order ULC labelled fire extinguishers of types suitable for fire hazard in each case, and locate them in prominent location and to approval of jurisdictional authorities.
- 8.10 Where flammable materials are being applied, ensure that adequate ventilation is provided, spark-proof equipment is used, and smoking and open flames are prohibited.

## **9 DIMENSIONS**

- 9.1 Check all dimensions at the site before fabrication and installation commences and report discrepancies to the Consultant.
- 9.2 Where dimensions are not available before fabrication commences, ensure that dimensions required are agreed upon between the parties concerned.
- 9.3 Prior to commencing work, ensure that clearances required by jurisdictional authorities can be maintained
- 9.4 Wall thicknesses and openings shown on the drawings may be nominal only; ascertain actual sizes at the site.
- 9.5 Verify dimensions of shop fabricated portions of the Work at the site before shop drawings and fabrications are commenced. The Owner will not accept claims for extra expense by reason of non-compliance with this requirement.
- 9.6 Fabricate and erect manufactured items, shop fabricated items, and items fabricated on or off site, to suit site dimensions and site conditions.
- 9.7 In areas where equipment is to be installed, check dimensional data on equipment to ensure that area and equipment dimensions are compatible with necessary access and clearance provided. Ensure that equipment supplied is dimensionally suitable for space provided.
- 9.8 The mechanical and electrical drawings are intended to show approximate locations of mechanical apparatus, fixtures, equipment, piping and duct runs, electrical apparatus, fixtures, outlets, equipment, units, and conduit in diagrammatic form and wherein the mechanical and electrical items are not dimensioned, consider their locations to be approximate. Check the drawings and confer with the Consultant to settle the actual locations of these items as may be required to suit aesthetic and site conditions. Such relocation shall be done without change to the Contract Price.
- 9.9 Leave areas clear where space is indicated to be reserved for future equipment, including access to such future equipment.

- 9.10 Whether shown on the Drawings or not, leave adequate space and provision for servicing of equipment and removal and reinstallation of replaceable items such as motors, coils and tubes.

## **10 RELOCATION OF MECHANICAL AND ELECTRICAL ITEMS**

- 10.1 The Owner and the Consultant reserve the right to relocate outlets at a later date, but prior to installation, without additional cost to Owner, assuming that the relocation per outlet does not exceed 3000 mm from the original location. No credits will be anticipated where relocation per outlet of up to and including 3000 mm reduces materials, products and labour.
- 10.2 Should relocations per outlet exceed 3000 mm from the original location the Contract Price will be adjusted in accordance with the provisions for changes in the Contract Documents.
- 10.3 Alter the location of pipes and other equipment, without additional cost to the Owner, if approved, provided the change is made before installation.
- 10.4 Make necessary changes, due to lack of coordination, as required and when approved, at no additional cost, to accommodate structural and building conditions.

## **11 EXPANSION, CONTRACTION, AND DEFLECTION**

- 11.1 Conform to manufacturer's recommended installation temperatures. If items, components, assemblies, systems, and finishes are installed at temperatures different from operation or service temperatures, make provisions for expansion and contraction in service as acceptable to manufacturer and consultant. Repair all resulting damage should expansion and contraction provisions provide inadequate.
- 11.2 Make provisions for expansion and contraction due to temperature changes within components, Products and assemblies, and between adjacent components, Products and assemblies, and due to building movements including but not limited to creep, column shortening, deflection, sway and twist. Ensure provisions for expansion, contraction and building movements prevent damages from occurring to and within components, Products and assemblies.
- 11.3 Make adequate allowance at wall and partition heads for deflection of the structure above. Determine requirements from Consultant where additional information is required. Where partitions butt to underside of floor assembly, or structural framing, the clearance shall be based on the span of the members supporting the floor or structural framing. In making such allowance use methods which maintain the integrity of the wall or partition as a sound, and/or fire barrier.
- 11.4 Make provisions in pipes, plenums, ducts and vessels containing air and fluids as is necessary to prevent damage due to fluid and air induced pressure, surges and vibrations, to pipes, plenums, ducts and vessels and to adjacent components, assemblies and construction to which pipes, ducts, plenums and vessels are attached or pass through.

## **12 DIELECTRIC SEPARATION**

- 12.1 Ensure that a dielectric separator is provided in a permanent manner over entire contact surfaces to prevent electrolytic action (galvanic corrosion) between dissimilar materials. Similarly, prevent corrosion to aluminum in contact with alkaline materials such as contained in cementitious materials.

## **13 PRODUCTS AT SOUND ATTENUATING PARTITIONS**

- 13.1 Avoid sound transfer at sound attenuating partitions by careful location and treatment of mechanical and electrical equipments, ducts, grilles, diffusers, electrical outlets and boxes, and similar items. Where electrical boxes are back to back, serving each side, locate them at least 250 mm apart laterally and, if interconnected, use flexible connections.

## **14 FASTENINGS**

- 14.1 Include in the work of each section necessary fastenings, anchors, inserts, attachment accessories, and adhesives. Where installation of devices is in work or other sections, deliver and locate devices in ample time for installation.
- 14.2 Do not install fibre, plastic or wood plugs or blocking for fastenings in masonry, concrete, or metal construction, unless specified or indicated on drawings.
- 14.3 Install work with fastenings or adhesives in sufficient quantity to ensure permanent secure anchorage of materials, construction, components and equipment under static conditions, and to resist building thermal movement, creep and vibration.
- 14.4 Provide metal fastenings and accessories in same material, texture, colour, sheen and finish as metal on which they occur, unless indicated otherwise.
- 14.5 Prevent electrolytic action between dissimilar metals and materials.
- 14.6 Use non-corrosive hot dip galvanized steel fasteners and anchors for securing exterior Work, and where attached to, or contained within, exterior walls and slabs, unless stainless steel or other material is specified. Leave steel anchors bare where cast in concrete.
- 14.7 Space anchors within their load limit or shear capacity and ensure they provide positive permanent anchorage. Wood, or any other organic material plugs are not acceptable.
- 14.8 Conceal fasteners where indicated. Keep exposed fastenings to a minimum, space evenly and in an organized symmetrical pattern.
- 14.9 Fastenings which cause spalling or cracking of material to which anchorage is made are not acceptable.

14.10 Powder Actuated Fastenings:

- .1 Do not use powder actuated fasteners for the support of ceilings.
- .2 Do not use powder actuated fastenings on any portion of the Work, unless written consent for a specific use is obtained from the Consultant.
- .3 Only low velocity tools will be permitted under any condition. Operators to be qualified and to be in possession of a valid operator's certificate.

**15 ADJUSTING**

- 15.1 Ensure that all components of assemblies fit snugly, accurately and in true planes, and that moving parts operate positively and freely, without binding and scraping.
- 15.2 Verify that work functions properly and adjust it accordingly to ensure satisfactory operation. Lubricate Products as recommended by manufacturer.

END OF SECTION

## **1 DEMONSTRATION AND INSPECTION OF PRODUCTS AND SYSTEMS**

- 1.1 Arrange for a demonstration of systems and operating Products upon the 100% completion of their installation and prior to certification for Substantial Performance.
- 1.2 Include in the arrangements for the attendance of the Consultant, Owner, jurisdictional authorities, and personnel assigned by the Owner for the operation of the systems and/or Products.
- 1.3 Demonstrations shall be conducted by the Subcontractor responsible for the installation of the systems and/or Product, assisted by representatives of the manufacturer or supplier. All personnel conducting the demonstration shall be completely knowledgeable of all conditions of the operating, functioning and maintenance of the systems and/or Products.
- 1.4 Owner's representative will acknowledge the successful completion of each demonstration on a form provided by the Contractor. The form shall be agreed to by the Owner, Consultant and Contractor prior to demonstration and testing.
- 1.5 Submit copies of letters from manufacturers of Systems and/or Products before making application for certificate of Substantial Performance to verify that the Products has been installed and connected correctly, and that it is operating in a satisfactory manner. The certification shall be based upon inspection and testing of the Products by competent technical personnel. Include in letter of certification the names of personnel conducting the testing and inspection, the methods of inspection utilized, and the location in the building of the Products certified.
- 1.6 Following submission of letters of certification and their acceptance by the Owner, the owner shall have the right to use the Products on a trial basis and for instructing their personnel in its use.
- 1.7 To read in conjunction with TDSB Requirements for close-out and commissioning.

## **2 FINAL INSPECTIONS AND CLOSE OUT**

- 2.1 Submit proposed closeout procedures and schedule of inspection to Consultant for approval before final demonstrations and inspections commence.
- 2.2 Arrange for, conduct and document final demonstrations, inspections, close-out and take-over at completion of the Work in accordance with procedures described in OAA/OGCA TAKE-OVER PROCEDURES, OAA/OGCA Document No. 100. Where "Architect" is referred to in Document No. 100 it shall mean Consultant.

**3 CERTIFICATE OF COMPLIANCE**

- 3.1 Submit Certificates of Compliance, prior to the application for Substantial Performance, for each of the following items.
- .1 An affidavit relative to the use of lead-free solder for all domestic water lines, regardless of location.
  - .2 Products for which Material Safety Data Sheets have been submitted and accepted.
  - .3 Other Work/Products identified in the Contract Documents as requiring a Certificate of Compliance.
- 3.2 Each Certificate of Compliance shall indicated names and addresses of the project, the Owner, the date of issue, product description including name, number, manufacturer, with a statement verifying that the Work/Product installed meets specified requirements and, if applicable, complies with the submitted and accepted Material Safety Data Sheets.
- 3.3 Each Certificate of compliance shall be issued on the subcontractor's letterhead, properly executed, under whose work the prospective Work/Product has been provided.
- 3.4 Each Certificate of Compliance shall be endorsed by the Contractor with his authorized stamp/signature. Ensure that submissions are made to allow sufficient time for review without delaying progress of scheduled completion.

END OF SECTION

1           **GENERAL**

- 1.1           Provide labour, Products, equipment, services, tools, and supervision necessary for cutting and patching work in accordance with the Contract Documents.
- 1.2           Obtain Consultant's approval prior to cutting, boring or sleeving load-bearing members.

2           **DEFINITION(S)**

- 2.1           The terms 'make good', 'making good', 'made good', 'restore to existing', 'patch', 'repair', or similar words or phrases are used in standards and these Contract Documents to mean the following, unless context provides otherwise:
  - .1           Make good materials and finishes which are damaged or disturbed during the process of additions and reconstruction under the Contract.
  - .2           Where existing work is to be made good, match new work exactly with the existing work in material, form, construction and finish unless otherwise noted or specified.
  - .3           Where existing work is to be made good, there shall be no visible difference in appearance, performance, or aesthetics between the existing work and the new work by the naked eye at a distance of 3 metres from the surface being made good.

3           **SUBMITTALS**

- 3.1           Submit written request in advance of cutting or alteration which affects:
  - .1           Structural integrity of any element of the Structure or Contract.
  - .2           Integrity of weather-exposed or moisture-resistant elements.
  - .3           Efficiency, maintenance, or safety of any operational element.
  - .4           Visual qualities of sight-exposed elements.
  - .5           Work of Owner's or Other Contractors.
- 3.2           Include in request:
  - .1           Identification of Contract.
  - .2           Location and description of affected Work.
  - .3           Statement of necessity for cutting or alteration.
  - .4           Description of proposed Work and products to be used.
  - .5           Alternatives to cutting and patching.

.6 Effect on work of Owner's or Other Contractors.

.7 Date and time Work will be executed.

3.3 Obtain Consultant's approval of proposed method of cutting prior to proceeding with the Work.

#### **4 PRODUCTS**

4.1 Same quality or better than Products incorporated in original installation.

#### **5 PREPARATION**

5.1 Inspect existing conditions, including elements subject to damage or movement during cutting and patching.

5.2 After uncovering, inspect conditions affecting performance of the Work.

5.3 Beginning of cutting or patching means acceptance of existing conditions.

5.4 Provide supports to assure structural integrity of surroundings; devices and methods to protect other portions of the project from damage.

5.5 Provide protection from elements for areas which may be exposed by uncovering Work; maintain excavations free of water.

5.6 Protect work such as floors, finishes, trim, etc., as completely as possible to hold the replacing of damaged work to a minimum.

5.7 Preparation for new finishes:

.1 Remove existing finishes, including painting.

.2 Fill cracks and depressions with suitable filler and finish smooth, as recommended by the manufacturer of the new finishes.

.3 Grind protrusions level with substrates and finish smooth.

.4 Remove all evidences of existing adhesive, grease, oil, soil and other encrustations of foreign material by washing, scraping and grinding if necessary.

.5 Clean and prepare substrates to receive new work.

#### **6 EXECUTION**

6.1 Execute Work to avoid damage to other Work.

6.2 Execute cutting, fitting and patching including excavation and fill to complete the Work.



- 6.3 Employ appropriate trades with skilled labour to perform cutting Work.
- 6.4 Fit Work segments together, to integrate with penetrations through surfaces and with other Work.
- 6.5 Remove and replace defective and non-conforming Work.
- 6.6 Do any drilling, cutting, fitting, patching and finishing that may be required to make the various classes and kinds of other Work fit together in a professional and finished manner. Make watertight connections with adjoining structures.
- 6.7 Provide openings in non-structural elements of Work for penetrations of mechanical and electrical Work.
- 6.8 Execute Work by methods to avoid damage to other Work and which will provide proper surfaces to receive patching and finishing.
- 6.9 Cut Products using proper equipment and methods. On rigid materials, use a masonry saw or core drill. Pneumatic or impact tools are not allowed on masonry work without prior approval.
- 6.10 Where new Work connects with existing structures, cut, patch and make good existing work to match original condition.
- 6.11 Be responsible for correct formation and bridging of openings in masonry and structural walls as required.
- 6.12 Ensure compatibility between installed Products and security of installation.
- 6.13 Restore Work with new Products in accordance with requirements of the Contract Documents.
- 6.14 Fit Work airtight to pipes, sleeves, ducts, conduits and other penetrations through surfaces.
- 6.15 Properly prepare surfaces to receive patching and finishing.
- 6.16 Refinish surfaces to match adjacent finishes; for continuous surfaces refinish to nearest intersection; for an assembly, refinish entire unit.

END OF SECTION

## **1      PROGRESS CLEANING**

- 1.1      Remove from finish work, spatters, droppings, soil, labels, and debris, before they set up.
- 1.2      Ensure that only cleaning materials are used which are recommended for the purpose by both the manufacturer of the surface to be cleaned and of the cleaning material.
- 1.3      Maintain building work areas "broom clean" at least on a daily basis, but shall also be done immediately before finishing work.
- 1.4      No waste material may be burned or buried at site. Remove as often as required to avoid accumulation, no less than, at the end of each working day.
- 1.5      Remove packaging materials and debris from the site immediately product and equipment is unwrapped or uncrated.
- 1.6      Ensure that volatile fluid wastes are not disposed of in storm or sanitary sewers, in open drain courses, or anywhere on site.
- 1.7      Do not allow waste material and debris to accumulate in an unsightly or hazardous manner. Sprinkle dusty accumulations with water. Provide containers in which to collect waste material and debris. Dispose of hazardous products in accordance with requirements of jurisdictional authorities.
- 1.8      Ensure that cleaning operations are scheduled to avoid deposits, of dust or other foreign matter on surfaces during finishing work and until wet or tacky surfaces are cured.
- 1.9      Provide instructions for final cleaning of finishing work, and for inclusion in Maintenance and Operating Manuals.

## **2      FINAL CLEANING**

- 2.1      Before final inspection, replace glass and mirrors broken, damaged, and etched during construction, or which are otherwise defective.
- 2.2      In addition to requirements for progress cleaning, Work shall include final cleaning by skilled cleaning specialists on completion of construction.
- 2.3      Remove temporary protections and make good defects before commencement of final cleaning.

- 2.4 Final cleaning shall remove dust, stains, paint spots, soil, grease, fingerprints, and accumulations of construction materials, interior and exterior to the building for all new work throughout new and existing Building. Work shall be done in accordance with manufacturer's instructions for each material. This work shall include:
- .1 Washing of concrete floors.
  - .2 Cleaning and polishing of glass, mirrors, porcelain, enamel and finish metals.
  - .3 Vacuum cleaning of ceilings, walls and floors.
  - .4 Cleaning and polishing of ceramic tile floors.
  - .5 Cleaning of resilient flooring.
  - .6 Buffing of resilient flooring followed by two light coats of wax, each buffed.
  - .7 Washing clean of glazed wall surfaces.
  - .8 Cleaning of hardware, mechanical fixtures, plumbing fixtures, lighting fixtures, cover plates, and equipment, including polishing of their finish metal, porcelain, vitreous, and glass components.
  - .9 Cleaning of windows and entrances, both interior and exterior surfaces.
- 2.5 Maintain cleaning until Owner has taken possession of building or portions thereof.

END OF SECTION

## **1 GENERAL**

- 1.1 Submit digital copy of closeout documents 15 days prior to any request for substantial completion for Consultants' review.
- 1.2 Hand over to the Owner two (2) copies of a comprehensive operations and maintenance manual and material suitable for the Owner's maintenance employees in hardcopy and one(1) digital copy in the form of USB. Manuals shall cover all Products supplied and installed under the Contract.
- 1.3 Submit digital draft of the operation and maintenance manuals for the Consultant's review at least 15 days before testing systems and equipment. Incorporate alterations and additions, as found to be necessary during testing, and prepare the final version of the manual from the corrected draft.
- 1.4 Submit final version of operation and maintenance manuals prior to substantial performance.
- 1.5 Testing of systems and equipment will not be deemed to be complete until the requisite number of copies of the final version of the manuals has been handed over to the Consultant and Owner.
- 1.6 If standard literature is incorporated into the operations and maintenance manual, any irrelevant information shall be deleted, or suitably noted.
- 1.7 The manuals shall have sufficient detail in order that the Owner can totally maintain the equipment without outside help.
- 1.8 Submit all material in English.
- 1.9 Refer to TDSB - General Conditions and Scope of Work for additional requirements for Contract Close-out and operation and maintenance manuals.

## **2 FORMAT**

- 2.1 Organize data in the form of an instructional manual.
- 2.2 Binders: Commercial quality, 219 x 279 mm, maximum "D" ring size.
- 2.3 When multiple binders are used, correlate data into related consistent groupings.
- 2.4 Cover: Identify each binder with type or printed title "Contract Record Documents"; list title of Contract, identify subject matter of contents.
- 2.5 Arrange content by systems or process flow, under Section numbers and sequence of Table of Contents.
- 2.6 Provide tabbed fly leaf for each separate Product and system, with typed description of Product and major component parts of equipment.

- 2.7 Text: Manufacturer's printed data, or typewritten data on 20 pound paper.
- 2.8 Drawings: Provide with reinforced punched binder tab. Bind in with text; fold larger drawings to size of text pages.
- 2.9 Digital binders to follow similar format at noted above.

### **3 CONTENTS**

- 3.1 Operation and maintenance manuals shall contain the following minimum information and data:
  - .1 Table of contents: Provide title of Contract; names, addresses, and telephone numbers of Consultants and Contractor with name of responsible parties; schedule of Products and systems, indexed to content of the volume.
  - .2 For each Product or system: List names, addresses and telephone numbers of Subcontractors, suppliers and service representatives, including local source of replacement supplies and parts including telephone numbers.
  - .3 Warranties: Warranties are between the Contractor and Owner. Warranties shall include, as a minimum:
    - .1 Description of warranty coverage.
    - .2 Date warranty starts (being date of Contract Completion).
    - .3 Date warranty expires.
    - .4 Contact name, address and phone number (the Contractor shall also be responsible for advising the Owner of changes in contact information during the warranty period).
    - .5 Equipment and components performance curves.
    - .6 Hydro certificates.
  - .4 Reports: For each Product or system provide the following:
    - .1 Manufacturer's certified reports
    - .2 Factory test reports.
    - .3 Field testing reports.
  - .5 Details of design, construction and/or fabrication features, component function and maintenance requirements, to permit effective start-up, operation, maintenance, repair, modification, extension and expansion of any portion or feature of the installation.
  - .6 Technical data, Product data, supplemented by bulletins, component illustrations, detailed views, technical descriptions of items and parts lists.
  - .7 Schematics, interconnection lists: Manuals shall be complete with schematic and wiring diagrams, wiring interconnection lists and diagrams fully cross referenced and coordinated, printed circuit board layouts including the component identification,

- component parts list with electronic substitution equivalent. Provide cross referenced components lists and sequence of operations.
- .8 Trouble shooting and fault location guide: Instructions to facilitate quick return of malfunctioning equipment to operation.
  - .9 Routine servicing and preventative maintenance schedule for Products and/or estimated hours required for routine servicing and preventative maintenance tasks.
  - .10 List of recommended spare parts and recommended quantity of each item to be stocked based on spare part availability and re-order time.
  - .11 Complete set of reviewed shop drawings.
  - .12 Product data: Mark each sheet to clearly identify specific Products and component parts, and data applicable to installation; delete inapplicable information.
  - .13 Drawings: Supplement Product data to illustrate relations of component parts of equipment and systems, to show control and flow diagrams and as required in the Specifications.
  - .14 Typed text: As required to supplement Product data. Provide logical sequence of instructions for each procedure, incorporating manufacturer's instructions and as required in the Specification.
  - .15 Refer to TDSB list of requirements and apply most stringent.

#### **4 RECORD DRAWINGS**

- 4.1 Consultant will prepare all required drawings on CAD, using AutoCAD. AutoCAD version to suite Owner's CAD requirements.
- 4.2 CAD drawings to meet the requirements of the Owners or Consultant's CAD Standards and Procedures and will be based in the red line prepared and provided by the Contractor .
- 4.3 Supply and hand over to the Consultant, one red line copy of the record contract documents as specified in section 01 78 00.
- 4.4 Prior to Contract Completion, supply and hand over to the Consultant, one complete set of CAD Drawing Files in AutoCAD format and one complete set of PDF Drawings on USB for each final drawing prepared under this Contract and one complete 11" x 17" hard copy set, including but not limited to circuit drawings, equipment layout drawings, and shop drawings.
- 4.5 Text files shall be written in word processing program acceptable to Owner.

**5 TRANSMITTAL**

- 5.1 Forward storage media to the Owner through the Consultant with a transmittal form. Transmittal shall contain the list of file names contained on the storage media.
- 5.2 Data forwarded to the Owner shall contain the following files in addition to the design information:
- .1 Library parts/cells used in the design files.
  - .2 Level convention used for each design file.
  - .3 Plotting instructions used to prepare hard copies including colour tables, pen tables and plot scale.
  - .4 Working units of the design files.
  - .5 Font library, if the standard is not used.

END OF SECTION

**1 EXTENDED OR SPECIAL WARRANTIES**

- 1.1 Conform to requirements of Warranty General Conditions.
- 1.2 Provide in writing, extended warranties having warranty periods greater than 1 year in duration.
- 1.3 Provide extended warranties for the stipulated Work and for duration's specified in each trade Section.
- 1.4 Wherever equipment manufacturers make available extended warranties/guarantees on parts and components of equipment, the Contractor shall be responsible for obtaining product extended warranties/guarantees on behalf of the Corporation from the manufacturers.

**2 LIST OF EXTENDED OR SPECIAL WARRANTIES**

- 2.1 The following is a compilation of extended or special warranties which extend beyond the 12 months required under the General Conditions of Contract or which have special conditions attached to them.
- 2.2 This list is given for convenience only and may not be complete. There may exist warranties in Specifications or elsewhere in Contract Documents, or warranties may be available for products supplied for the Work without such warranties being stipulated in the Contract Documents. All such warranties are applicable and in force whether listed in this summary or not.
- 2.3

SECTION	WORK, SYSTEM OR PRODUCT	WARRANTY PERIOD
06 20 00	Finish Carpentry	2 years
06 24 00	High Pressure Decorative Laminate	2 years
06 40 00	Architectural Wood Work	2 year AWMAC Guaranty or two year 100% maintenance bond
07 62 00	Sheet metal flashing and Trim	5 years
07 92 00	Joint Sealants	5 years
08 12 13	Hollow metal Frames	2 years
08 13 13	Hollow Metal Doors	2 years
08 31 00	Access Doors and Panels	5 years
08 71 00	<b>Door Hardware</b>  Mortise Hinges Locks (Mortise) Exit Devices Door closers –mechanical (4040XP) Door Operators - Electro mechanical Electric Hold Open Devices - Electro mechanical Overhead stops/holders	1 year 3 years 3 years 30 years 2 years 2 years 1 year 1 year



	Floor/Wall stops Electric Strikes/Key Switches/Power Supplies	1 year
08 80 00	<b>Glazing</b>	5 years
09 90 00	Paint and Coating	2 years or 100% maintenance bond
12 24 13.16	Manual Roller Window Shades	10 years

2.4 Refer to Divisions 22 and 23 Mechanical and 26 Electrical for warranty requirements.

END OF SECTION

## **1            PROGRESS RECORDS**

- 1.1            Maintain on site, permanent written records of daily progress of the Work. Records shall be open to review by Consultant and Owner at all times and a copy shall be furnished to Consultant on a weekly basis.
- 1.2            Records shall show dates of commencement, progress and completion of various trades and items of work. Particulars pertaining to number of employees of various trades and type and quantity of equipment employed daily, temperature, protection methods and other such data shall be noted.

## **2            AS -BUILT DRAWINGS**

- 2.1            Authorized deviations from drawings shall be marked in red accurately on one set of drawing prints in a neat, legibly printed manner and shall be dated. Prior to Substantial Performance application, neatly transfer the recorded information to a digital file (PDF) with red marking and submit the digital file to the Consultants for review.
- 2.2            Maintain record drawings up to date as Work progresses. Status of maintained record drawings may be considered as a condition for validation of applications for payment.
- 2.3            Identify each record drawing as "Contract As-Built Drawings" and maintain the record drawings in good condition. Make record drawings available to the Consultant at all times.
- 2.4            As-Built drawings shall include accurate dimensioned record of deviations and changes in Work from drawings.
- 2.5            As-Built drawings shall be signed and dated by Contractor.
- 2.6            Submit As- built drawing to Consultant for review and make corrections as directed by Consultant.
- 2.7            Record accurately all deviations in the Work.
- 2.8            Accurately record locations of concealed structure, mechanical and electrical services and similar Work not clearly in view, the location of which is required for maintenance, alteration Work and future additions. Do not conceal such Work until the location has been recorded.
- 2.9            Accurately record locations of equipment bases, anchors, concrete pads and roof curbs, sleeves, piping, conduits, ducts, maintenance holes and valves, etc. located either below, outside or within structure.
- 2.10            Where piping, conduits and ducts are underground, underfloor, embedded in concrete or otherwise in inaccessible locations, accurately record with respect to

- structure column lines or walls and elevations with respect to finished floor levels or grades referenced to the centre line of components.
- 2.11 Accurately record any components which will be in inaccessible locations for Consultant's review before the component is covered, or buried, or made inaccessible.
- 2.12 Clearly and prominently mark each drawing AS-BUILT DRAWING prepared by \_\_\_\_\_ (name of Contractor) for each discipline.

END OF SECTION

## 1 General

### 1.1 SECTION INCLUDES

1. Administrative and procedural requirements for instructing Owner's personnel, including the following:
  - 1.1. Demonstration of operation of systems, subsystems, and equipment.
  - 1.2. Training in operation and maintenance of systems, subsystems, and equipment.
  - 1.3. Demonstration and training video recordings.

### 1.2 DEMONSTRATION & TRAINING

1. Demonstrate start-up, operation, adjustment, control, servicing, trouble-shooting and maintenance of each item of equipment at agreed upon times, at locations designated by the owner. Arrange for demonstrations 15 calendar days prior to Take-Over date or Substantial Performance date. Submit Operation and Maintenance manuals for consultant review and acceptance before that.
2. Owner will prepare a list of personnel to receive instructions, and will coordinate their attendance at agreed upon times.
3. Prior to demonstrations, ensure equipment has been inspected and put into proper operation, including start-up, testing, adjusting and balancing.
4. Arrange for competent facilitators and instructors to perform demonstration and training.
5. Arrange for attendance of sub-contractors and Consultant or Sub-consultant where necessary.
6. Instruct personnel in phases of operation and maintenance using operation and maintenance manuals as the basis of instructions.
7. Review contents of operating and maintenance manual in detail to explain all aspects of operation and maintenance.
8. Allow Owner to video record demonstration and training instructions.
9. Prepare and insert additional data in operations and maintenance manuals when the need for additional data is apparent during instructions.

END OF SECTION

**Part 1 GENERAL**

**1.1 General**

- .1 A formal commissioning process is in place for this project. Work shall include but not limited to the implementation of coordinated commissioning activities, executed by the Contractor and Commissioning Provider (CxP).
- .2 This section describes the commissioning of the building components, equipment and systems and outlines the duties and responsibilities of the Commissioning Team.
- .3 The commissioning process shall be applied to listed building components, and all products, equipment and systems provided under Division 23 through Division 25.
- .4 The Commissioning Provider as directed by the Owner shall develop a Commissioning Plan.

**1.2 Related Sections**

- .1 Plumbing System Cx Section 22 08 00
- .2 HVAC System Cx Section 23 08 00
- .3 Integrated Automation System Cx Section 25 08 00
- .4 Communication system Cx section 27 08 00
- .5 Safety and Security Cx Section 28 08 00

**Part 2 PRODUCTS**

**2.1 Definitions**

- .1 Commissioning Team
  - .1 Personnel that will be directly involved in the building commissioning process. The Commissioning Team shall comprise of Commissioning Provider, Owner's Representatives, Contractors, the Consultants and Independent Third-Party Testing Agencies.
- .2 Commissioning Plan
  - .1 The Commissioning Plan defines the scope and approach to the Total Building Commissioning Program that is to be executed for the project.
  - .2 The Commissioning Provider shall develop the Commissioning Plan once the IFC drawings and specifications are ready.
- .3 General Contractor
  - .1 The contracting firm responsible for management of the construction process for the project.

- .4 Contractor
  - .1 The mechanical construction firms and their sub-contractors that are responsible for physical construction of the project.
- .5 Consultants
  - .1 The architects / engineers that are responsible for production of the design drawings and specifications for the project as well as the base contract administration, inspection, quality assurance and acceptance activities.
  - .2 The design consultants are not required to be involved in any of the commissioning verifications or performance testing programs, but may witness these activities at their discretion.
- .6 Third Party Testing Agencies
  - .1 Specialty firms or agencies retained to conduct acceptance tests on a system of component and provide a certificate of acceptance and conformance to governing standards.
- .7 Out of Contract Tests
  - .1 Testing requirements that are not covered as part of the construction documents but are required to be carried out by certified agencies. Examples would be high voltage testing programs, building envelope testing and air quality testing.
- .8 In Contract Tests
  - .1 Testing requirements that are defined in the contract documents and are the contractors responsibility to carry out. Tests may be witnessed by the Consultant, Owner's Representative and Commissioning Providers. Documented test results are turned over for review.
- .9 Commissioning Check Sheets
  - .1 Mechanical check sheets that are specific to systems and components for the project that are used for verifying and testing of the work. These shall be generated by the Commissioning Provider.
  - .2 The commissioning checksheets will be laid out to record three types of site information; technical equipment data, static installation checks and operation checks. Sample checksheets are included at the end of this section.
  - .3 The checksheets will have the equipment's specified and approved shop drawing information input by the Commissioning Provider. The Contractors shall be responsible for completing the technical data section by verifying through the equipment nameplates on site that the equipment installed matches the approved shop drawings.
  - .4 The checksheet manuals will be turned over to site following approval of shop drawings. Checksheets will be prepared for all mechanical systems with the exception of the BMS Controls.
  - .5 The Commissioning Provider will use copies of the BMS

Contractor's  
point verification forms for commissioning of the BMS Systems.

- .10 Contractor Start-Up Program
  - .1 Contractor / Supplier checking of the physical installation of the work and reviewing the completeness of system installation and readiness for start-up prior to Commissioning verification activities occurring.
  - .2 Contractor start-up program activities are conducted by the mechanical contractors or their sub-trades and their equipment suppliers, and may be witnessed by the Consultant and / or Commissioning Agents.
- .11 Static Inspections
  - .1 Systematic detailed inspections of mechanical systems and components carried out under the Commissioning Program by personnel from the Commissioning Team. Site personnel will utilize check sheets for recording installation readiness or deficiencies on a component and system bases. Timing of static inspections is tied to construction progress and occurs once contractor checks have been completed.
- .12 Acceptance Inspections
  - .1 A series of formal inspections carried out by the Consultants for systems that result in acceptance of the Work as complete.
- .13 Performance Testing
  - .1 Performance tests are specific hand-on tests conducted with test instruments, to prove that the systems as installed meet both the specified performance requirements for major pieces of equipment and that installed system performance meets the design intent and specified operating requirements.

## **2.2 The Commissioning Team**

- .1 The Commissioning Team shall consist of:
  - .1 The Commissioning Provider (retained by the Owner).
  - .2 Owner's Representatives
  - .3 The Consultant
  - .4 General Contractor
  - .5 Mechanical Contractors and Sub-Contractors

## **2.3 Duties of the Team**

- .1 Commissioning Provider:
  - .1 Assemble Commissioning Team and ensure coordination of activities with the team in carrying out the Commissioning Plan.
  - .2 Assists in the preparation of the Owner's Design Intent documentation and reviews the Consultant's Basis of Design Report.
  - .3 Conducts detail Design Reviews of the mechanical and control

- construction documents prior to project tender. Provide comments to the Owner and the Consultant. Track comments for resolutions (For the projects with construction budget above \$2M only).
- .4 Develop commissioning specifications for inclusion in tender package.
  - .5 Development of the Commissioning Plan including involvement of Owner's personnel, Out-of-Contract testing requirements, and overall commissioning team responsibilities.
  - .6 Convene and chair commissioning meetings.
  - .7 Review all mechanical equipment shop drawings and provide reports as necessary to the Owner and the Consultant. The BMS shop drawing requires a separate detail review and report submission. Track the issues and record resolutions.
  - .8 Liaison between Project Management, the Construction and Design Team and coordinates all related correspondence.
  - .9 Commissioning Agents shall witness major mechanical equipment start-up procedures. Witness equipment start-ups onsite and provide reports to the Owner. All findings shall be summarized in Master Issue Log.
  - .10 Issue Commissioning Reports on system completeness/deficiencies and after each site visit. All findings shall be summarized in Master Issue Log.
  - .11 Review all contractor's mechanical submittals including pressure test reports, cleaning/flushing reports, air/water balancing reports, O&M manual. A separate report shall be submitted to the Owner for each. All issues shall be recorded in Master Issue Log.
  - .12 Review the equipment installations in the field and complete and sign off equipment static checks on the commissioning checksheets after contractor completion.
  - .13 Adjusts as required the Commissioning Plan after Tender and prepares Commissioning Manuals complete with equipment check sheets and performance testing scopes for mechanical systems once shop drawings are approved.
  - .14 Perform detail Functional Performance Testing on each equipment and whole system together. The Commissioning Provider shall develop the functional testing scripts in the beginning of the construction phase and discuss the scenarios and steps with the respective contractors throughout the Commissioning Meetings.
  - .15 Verify, through performance testing, that systems operate as per design intent and contract documents. Document results in the operation checks section of the commissioning forms.
  - .16 The commissioning Provider shall document all findings in a Master Issue Log. The Commissioning Provider shall return on site to double check the issues and retest as necessary, record each item's resolution and report to the Owner.
  - .17 Development of a Commissioning Schedule in conjunction with the Construction Schedule.



- .18 Turnover of Final Commissioning Manual c/w with signed-off check sheets, verification results, system descriptions, and contractor testing documentation.
- .19 Issues a final commissioning summary report.
- .2 Owner's Representatives
  - .1 Copied with all commissioning reports
  - .2 Reviews and implements, as deemed necessary, all recommendations and suggestions identified in the commissioning reports.
  - .3 Review and comments on the Commissioning Reports as prepared by Commissioning Provider and follow up with the Contractors as needed.
- .3 Consultant
  - .1 Conduct periodic construction reviews to determine that the work is in general conformance with the contract documents.
  - .2 Review as-built records as required to the Contract Documents.
  - .3 Provide support to the Commissioning Provider as a part of the commissioning process. This shall include providing adequate space for equipment installation and maintenance.
  - .4 Prepare and submit the final as-built design intent and operation parameters documentation for inclusion in the O&M manuals.
  - .5 Review and approve the O&M manuals.
  - .6 Provide a design narrative and sequence documentation requested by the CxP, and assist in clarifying the operation and control of commissioned equipment in areas where the specifications, control drawings or equipment documentation is not sufficient for writing detailed testing procedures.
  - .7 The Design Professional retains responsibility for system evaluation, adequacy of the system to meet design intent, capacity of the system, quality check or any of the other elements of the design.
  - .8 Attend commissioning scoping meeting and other selected commissioning team meetings as necessary.
  - .9 Review as-built record as required by the Contract Documents and turn them over to the CxP for inclusion in final project documentation.
  - .10 Witness testing of selected pieces of equipment and systems
- .4 General Contractor and Contractors
  - .1 Cooperate fully with Commissioning Provider in execution of the Commissioning Plan.
  - .2 Provide copies of all shop drawings and equipment start-up reports to the Commissioning Provider.
  - .3 Coordinate with the Commissioning Provider and provide dates for commissioning activities for development of the commissioning schedule.

- .4 Prepare and issue the equipment start-up plan.
- .5 Provide advanced notice at least seven (7) days prior to commencement of each procedure or series of procedures to allow the Commissioning Provider to arrange for witnessing of tests as required.
- .6 Verify that equipment and system start-ups have been completed by the contractors / equipment representatives and notify the Commissioning Provider that commissioning of systems can commence.
- .7 Should Commissioning Provider arrive on-site for a scheduled site visit/testing, or be called to site, it is assumed that the contractors and all parties will be prepared for the proposed work and the commissioning activities can take place with no issue.
- .8 All commissioning activities and tasks are designed to take place once and are single occurrence. In the event that the Commissioning Provider arrives on site at a prearranged time and equipment is not ready or task has been cancelled without notifying the Commissioning Provider, the contractor will be charged for additional fees for missed readiness based on time and material.
- .9 Provide completed Start-up forms/reports to the Commissioning Provider within five (5) days after completion of the task.
- .10 Utilizing the equipment check sheets prepared by the Commissioning Provider, complete the contractor's portion of the commissioning checks by completing the technical data sections verifying the installed equipment matches the specified and shop drawing requirements.
- .11 Completion of deficiencies as listed on the Commissioning Reports.
- .12 Submit all required documents to the commissioning Provider, i.e. duct/pipe pressure test reports, pipe flushing/cleaning reports, chemical treatment, equipment start-up reports, air/water balancing reports, BMS point to point verification report, BMS sequence of operation verification report, O&M manual and as-built drawings etc to Commissioning Provider, the Owner and the Consultant.
- .13 Assign the required manpower onsite as necessary to perform all commissioning activities.
- .14 Respond to the Commissioning Provider's questions, reports and comments on timely fashion.
- .15 Assign the required manpower to retest the deficiency and provide resolutions.
- .16 Assign HVAC and BMS technicians onsite to work with Commissioning Provider to perform Functional Performance Testing. The technicians shall be familiar with project and have the site-specific information.
- .17 The Contractor is responsible for verifying that all installed equipment is as per the mechanical shop drawings. The Contractor is to initial and date the check sheets when the equipment technical checks are complete and also when equipment installations are complete (static checks). The Commissioning Provider will check-off that the

technical data is correct, and will fill in the site-specific data for all static and operation checks. When all deficiencies are complete and the piece of equipment is operating as designed, the Contractor and Commissioning Agents will sign off the form. Provide Record Drawings and

- .18 When thorough testing of loading, staging and capacities in the construction phase can't be completed during the initial functional testing, testing is deferred to the appropriate season or load condition during occupancy. General Contractor and Contractors shall assign the required manpower onsite as necessary to perform all commissioning activities, respond to the Commissioning Provider's questions, reports and comments on timely fashion. Shall provide technical support and assist within their contract scope to remedy issues. Conducting a final Warranty Review to ensure there is sufficient time to remedy any noted outstanding items issues relating to the commissioned equipment.
- .19 Subsequent to providing the O&M Manuals and draft as-built drawings and completing all commissioning tasks and prior to applying for a certificate of substantial completion, shall provide all specified trainings.
- .20 Record in digital video format all demonstrations and specified training sessions, and provide one (1) complete copy on a Flash Drive to the Board.

**Part 3 EXECUTION**

- .1 The Commissioning Provider shall plan, organize and implement the commissioning process.
- .2 Duties as outlined in section 2.3 Duties of the Team, .1 Commissioning Team.

**END OF  
SECTION**

1. **GENERAL**

1.1 **DESCRIPTION**

1.1.1 Comply with Division 01 General Requirements.

1.1.2 Work includes demolition and removal to the full extent required by the drawings and as required to install new materials and equipment in preparation for the proposed work in the areas to be altered. Including but not limited to; all site clearing, stripping and removal of existing surfaces and structures, as shown on drawings and as required permitting installation of new work by other trades, and the removal of rubble and debris from the site for disposal.

1.1.3 The Contractor shall ensure that a thorough check of possible hazards, (asbestos contamination, excessive dust, electrical cables, etc.) is done prior to removal of existing constructions. If hazards are encountered, the Contractor must notify the Board in writing, prior to proceeding with Work. The Board will direct the process for remedial action.

Asbestos and other hazardous materials encountered during demolition shall be removed using procedures as detailed in Ontario Regulation 654/85, under the Occupational Health and Safety Act, regulating Asbestos on Construction Projects.

1.1.4 Cutting of new and existing work to accommodate Mechanical and Electrical work, unless otherwise noted, will be executed by the Mechanical and Electrical trades. Patching will be carried out by General Contractor.

1.2 **SCOPE OF WORK**

1.2.1 The work of this Section is for the demolition, removal and repair of all items required by the work, including:

- a) Demolition and complete removal of existing areas to be renovated to the extent indicated, including all obsolete finishes and fittings, tack-boards, chalkboards including obsolete miscellaneous equipment and services. All exit corridors to remain functional throughout the demolition.
- b) Demolition, renovation and restoration of surrounding site. Access to the site and to all areas of the school property must be maintained per Board requirements and / or Authorities Having Jurisdiction.
- c) Demolition shall be carried out in an orderly and careful manner. The debris and refuse of demolition shall be removed from the building and from the site promptly and at frequent intervals and shall not be allowed to accumulate.
- d) Unless noted otherwise, building materials resulting from demolition shall become the property of the Contractor, to be removed from the site promptly by the Contractor.
- e) Demolition and removal work shall include all exterior walkways, paving, landscaping, fencing and curbs which require removal and / or relocation to suit the new Work.
- f) Remove existing windows, doors, frames and walls in existing building where indicated.
- g) Remove, replace and / or relocate all HVAC equipment, lighting fixtures, plumbing and all other items required for the new Work and as indicated throughout the specifications and on the Contract Drawings.
- h) Removal of existing ACT and existing ceiling as required for mechanical, electrical and structural work within the existing building including hazardous material removal and all misc. connections: the Contractor will carefully remove existing ceilings within the existing school areas for installation / connection of the new services. The Contractor shall protect the existing grid in place (or remove and reinstate as required) and repair any damaged areas to new condition throughout within the Base Contract. Non-damaged tiles will be stockpiled in a clean, dry, safe manner for reinstatement within the existing areas of the school. Tiles of different pattern nor new tiles will be mixed in with existing tiles in any one room. Damaged tiles (scored, marked, uneven

edges, etc.) will not be reinstated and shall be replaced. The Contractor shall be entitled to a maximum extra of 15% of the total reinstated area for replacement tiles from the specified cash allowance. Replacement of damaged tiles above and beyond the 15% will be the responsibility of the Contractor unless they can document that such damage occurred prior to the Contractors handling of the ACT. All work to modify existing or new replacement ACT tiles and grid to suit new conditions / services shall be included in the Base Contract.

1.2.2 **Owners Preparations:**

- a) Board will savage items at their discretion for use on other areas of the school. The Board will remove all furniture and contents of cupboards to be retained, prior to start of demolition. Furniture will be moved out once at start of Contract and moved in once at the conclusion of the Contract. Any other moving required by the Contractors failure to meet schedule or other deficiencies – the full cost will be charged to the Contractor.

1.2.3 **Contractors Preparations:**

- a) Demolition work shall not proceed until precautions have been taken to keep the structure weather tight and/or dustproof screens have been erected to protect adjoining areas. Provide suitable barricades and warning signs. Provide sealed dust-proof barriers for all air-handling ductwork entering the place of Work and other openings that could communicate dust from the work place to the adjoining school areas.
- b) Support all loads while demolishing and until new load bearing material is in situ.
- c) Demolition of existing floors, ceilings, partitions, or other construction shall include the relocation of existing mechanical and electrical services wherever shown on drawings and/or identifiable at the site.
- d) Removal of all existing floor finishes, including underlay to original sub-floor at locations where new floor finish is called for, ready for application of new finishes.
- e) Remove abandoned services such as conduits, pipes, wiring, ducts, fixtures, equipment, etc., where required for the work or indicated on the drawings.
- f) Removal of existing electrical items including fixtures, etc., where required for the work or indicated on the drawings and not required to be relocated within the School premises.
- g) Removal of all mechanical items including plumbing fixtures, services, etc., where required for the work or indicated on drawings and/or where not required to be relocated within the School premises.
- h) Removal of existing millwork and making good, where necessary.
- i) Removal shall mean removal from site and safe disposal in a legal manner.
- j) Making good of existing materials to provide smooth, dust and grease-free surfaces, ready for the installation of required finishes.
- k) Existing construction, equipment, and finishes which are to remain shall be protected. Otherwise make good.
- l) Contractor shall review with Consultant which materials removed during the demolition shall be handed over to the Owner. They shall be removed from the site to a storage location within the school, if directed by the Owner.
- m) Carefully clean and store all materials and equipment to be reused.
- n) Maintain the existing building secure at all times and provide temporary secure closures as required.
- o) The work of demolition or service shutdowns which could affect the operation of the school program, shall be undertaken outside school hours and with prior approval of Board and school officials only.

1.2.4 **Demolition as follows:**

- i) Cut new openings in existing masonry walls.
- ii)
  - 1. For the work of items i), and ii), use wet concrete or masonry saws and carry work to a neat clean junction with constructions which area to remain.
  - 2. Concrete slabs on grades shall be cut to half depth only and broken out with pneumatic hammers to avoid cutting under floor services and provide a key for the replacement slab.

Failure to comply with this requirement makes the Contractor responsible for under floor services.

- iii) Remove portions of existing roof construction including cants, flashing, and structure for joining new roof. Patch and seal as required ensuring water tightness. Maintain warranty on existing roof .
- iv) Remove ceiling acoustic boards, arrange for safe storage and reinstall in the finished work only where called for on the drawings, otherwise provide new tiles to all renovated areas.
- v) Remove and / or modify existing windows, doors and screens, complete in preparation for alterations..
- vii) Remove existing floor finishes in preparation for new flooring.
- viii) Remove existing partitions, doors and frames, as indicated on drawings.
- ix) Remove existing millwork, fixtures and fittings as required for new work.
- x) Removal, recapping, and diverting of mechanical and electrical services as required.
- xi) All cutting or grinding shall be done by safe "wet" means. No dust shall be made airborne by grinding or cutting.
- xii) Co-ordinate with mechanical and electrical trades for cutting and patching.
- xiii) Removal of all existing cabinets, chalkboards, tack-boards where required for new work.
- xiv) Removal of all metal shelving, cabinets, where required for new work - hand over to Owner.

1.2.5 Repair work to include:

- i) Included in the General Work are miscellaneous items and work required to complete the alterations as detailed; i.e. rough and finished carpentry, structural steel, miscellaneous metal, concrete work and mechanical-electrical work.
- ii) Provide miscellaneous lintels for installation under Division 4.
- iii) Provide caulking required to close between various finishes as required. Caulking to be acrylic grey coloured sealant "Mono" or equal.
- iv) Provide rough and finished carpentry required by the drawings.
- v) Provide and install access doors required by the drawings.
- vi) Provide and install new finishes as required by the drawings and schedule.
- vii) Provide and install pre-finished metal angles to close between lockers and masonry.
- viii) Disconnect and reinstall mechanical and electrical items as required.

1.2.6 Exterior Work: The Contractor shall include in the tender all miscellaneous work exterior to the building indicated on the drawings and/or identifiable at the site required to complete the full scope of the Contract Work.

1.2.7 Mechanical and Electrical Equipment: Further specified in Mechanical and Electrical Divisions.

- a) Mechanical and Electrical Contractors shall make safe all services, identify equipment to be retained, re-used or handed over to the Owner. Contractor to do demolition and disposal unless otherwise specified.
- b) Contractor shall maintain all services required for continuing use of the school and property.
- c) Patching and repair of any openings in exposed or finished surfaces shall be by the trade responsible for the finish surface under the coordination of the Contractor. The Contractor shall coordinate all cutting, openings and patch and repair to minimize interference between trades and existing services. Note required fire stopping to maintain existing required fire separations and fire separations indicated within the new Work.
- d) Removal of partitions and doors and installation of new partitions and making of new openings for doors, etc., will require the relocation of mechanical and electrical equipment and outlets. The Contractor shall be responsible to obtain complete information on such alterations and services and equipment required for relocation prior to tendering and all such Work shall be included in the Contract.
- e) Contractor shall be responsible for removing redundant equipment, electrical and otherwise unless specifically noted elsewhere.

1.2.8 Making Good Finishes and Joining of Existing and New Work.

- a) Floors of altered areas must be finished flush and ready for final finish applications with adjacent existing finishes to remain.
- b) Where floor slab is required to be cored / drilled for new services, care must be taken to install new openings clear of structural members and existing services to remain. After installation of new services, all openings must be made watertight.
- c) Where existing floor to be cut for new services, remove existing vinyl floor tile and supply and install new vinyl tile as per finish schedule / existing condition. Patching shall not be evident.
- d) At existing openings in concrete block walls shown to be blocked up, masonry shall be keyed in with units identical to existing adjacent units, so that coursing and bond are continuous. Blocks to match adjacent in size, shape and pattern. Salvaged blocks free of defects and or mortar may be used to infill existing openings only at the approval of the Architect. Similarly for existing brick walls requiring patching. Do not use any salvaged materials in the construction of the new openings.
- e) Where new openings are shown to be cut into existing walls, Contractor shall break open the wall to size required, provide new steel angle or lintel block over the opening (as specified) and patch all adjacent materials.
- f) Where openings are blocked up in existing painted walls, where new openings are made, or where millwork or equipment are removed from walls; surface shall be completely repainted to the next "inside" perpendicular corner per Section 09900. All other walls of the same colour in the same room as patched wall shall be painted with one finish coat of paint. No patch painting will be permitted.
- g) All new horizontal runs of ducts, pipes and conduits shall be concealed in ceiling spaces, unless specifically noted otherwise.
- h) All new duct drops and risers shall be concealed in ceiling spaces, bulkheads or furrout duct shafts. All new pipe and conduit drops and risers shall be furred out or buried in walls as indicated. New devices on walls shall be recessed and new devices on existing walls shall be surface mounted. Exposed conduit and wiremould shall be painted in with existing wall colour.
- i) All existing ceiling components and ceiling mounted equipment shall be carefully removed where required.
- j) Existing extra ceiling tiles which are removed shall be turned over to Board staff for re-use depending on condition.
- k) Existing concrete and painted concrete floors shall be prepared according to manufacturers' instructions for new adhesive applied finishes or new paint finish per Room Finish Schedule.
- l) Special care must be taken not to damage existing roof. Any damage must be repaired as recommended and approved by the Consultant.
- m) Cutting, patching and flashing of the roof must be done in conformity with existing construction and adjacent surfaces. Integrity of the existing and new roofs must not be compromised.
- n) Cuts through the existing steel deck must be reinforced. Provide stamped engineered shop drawings, showing locations and sizes of cuts and all reinforcement.
- o) Provide roof curbs at roof mounted mechanical equipment and install roofing, flashing and counter-flashing to ensure weather tight seal.

### 1.3 SITE EXAMINATION

- 1.3.1 Verify all site conditions, which affect the work of this Section, and immediately report, in writing, all discrepancies and conditions which are at variance with drawings and specifications and could adversely affect the performance of this Section. Failure to do the above will imply acceptance of all conditions by the Contractor.
- 1.3.2 Contractor is responsible to document by record photographs of the existing condition of the areas of the work and the areas adjacent to it prior to starting demolition and construction. Copy of record photographs to be submitted to Architect and Owner **PRIOR TO COMMENCEMENT OF THE WORK**. Failure to submit existing condition photographs shall require the Contractor accept responsibility for any and all damaged materials in and around the place of the Work and for the provisions required to make good all such damage.

- 1.3.3 Claims thereafter, on account of damages or extra costs resulting from such discrepancies will be rejected, unless they are the direct result from such conditions which could not be definitely ascertained before commencement of work.
- 1.3.4 Existing utility and service locations shown on drawings for information only. Verify on site all underground and above ground services, whether or not shown on drawings and be fully responsible for locating and staking of said services on the site by public utilities companies. Verify also with Owner's maintenance and operations department with respect to the Owner's service.
- 1.3.5 The Consultant does not assume any responsibility for the accuracy and completeness of the documentation of such services and where shown on drawings.
- 1.3.6 Various parts of the remaining mechanical and electrical equipment will require alterations, removal and / or replacement to suit the requirements of the new Work. It is the responsibility of each contractor to determine the full extent of such alterations before tendering.
- 1.4 **STANDARDS AND CODES**
- 1.4.1 In addition to complying with all applicable provincial and municipal codes and regulations, comply with the requirements of all insurance carriers providing coverage for this work.
- 1.4.2 The use of explosives will not be permitted.
- 1.4.3 To Ontario Fire Code, Part 8, Demolition, including not limited to :
- a) Shutting off and capping services,
  - b) Management of combustible salvage, waste and rubbish,
  - c) Protection of persons and property,
  - d) Maintenance of fire firefighters access,
  - e) Provision of fire extinguishing equipment,
  - f) Maintenance of existing and/or temporary exits.
- 1.4.4 To CSA S350-M80 'Code of Practice for Safety in Demolition of Structures, the Ontario Occupational Health and Safety Act, and regulations of authorities having jurisdiction.
- 1.4.5 **QUALITY ASSURANCE:** Work of this section shall include protection measures, consisting of materials, constructions and methods, required by jurisdictional authorities to save persons and property from harm.
- 1.5 **PROTECTION**
- 1.5.1 Student and public safety and required exiting from the existing school must be maintained at all times.
- 1.5.2 Construction fence must be installed and construction area secured PRIOR to any Work undertaken at the Site. Enclosure must conform to Ministry of Labour and Municipal requirements in addition to provisions specified hereunder.
- Construction gates to be manned and supervised for pedestrian access at walkways and play areas during school operation and as directed by school staff.
- 1.5.2 Take all necessary precautions to protect the existing building, remaining fitments and furniture, etc. and services from damage during demolition work. Accept responsibility for any damage which may occur and make good without cost to the Board. Determine location of services situated within, or adjacent to, the site before demolition work commences. Accept responsibility for damage to existing services and make good without cost to the Board.



- 1.5.3 Maintain fire protection and enforce proper fire prevention practices in accordance with the Board's requirements and Authorities Having Jurisdiction.
- 1.5.4 Be responsible for maintaining the existing building in a weather and watertight condition at all times until the completion and acceptance of the Work. All damage caused to the building interior and/or furnishings of the existing building by neglect of the Contractor or any of his forces shall be made good at his expense including all costs and charges which may be claimed by the Board for damages or inconvenience suffered. Protection shall be adequate to provide security.
- 1.5.5 Building is to be occupied during construction. Provide for heated enclosures at exterior as required. Open salamanders are not permitted.
- 1.5.6 Floors walls and other objects to be retained shall be repaired and made good from all damage / alteration by this Contract. Where existing openings are closed up and new openings are constructed make good all adjacent surfaces to new condition. Where existing classroom doors and frames are removed, provide new frames and doors and make good all surfaces.
- 1.5.7 Contractor is responsible to document by record photographs the existing condition of the area of the work and the areas adjacent to it prior to starting demolition and construction. Copy of record photographs to be submitted to Architect **PRIOR TO COMMENCEMENT OF WORK.**
- 1.5.8 Ensure that adjacent private and public properties, both within and without the premises, are protected from damage resulting from Work of this Section. Install protection consisting of fences, hoarding, braces, railings, warning signs, visual and audible signals, barricades, and substantial constructions providing physical protection. Property shall include but not be limited by, structures, and their finishes and appurtenances; site improvements; trees, planting and landscaping; furnishings, fixtures, hardware and equipment.
- 1.5.9 Prevent movement, settlement, or collapse of adjacent services, sidewalks, driveways, trees, building or building parts.
- 1.5.10 Protect existing services from damages. If necessary, relocate active services to ensure that they function continuously in safety and without risk of damage. Cap off and remove unused services encountered during demolition after approval is given by the utilities or Jurisdictional Authorities, whichever may apply, and the Consultant.
- 1.5.11 Protect existing items designated to remain and items designated for salvage. In the event of damage to such items, immediately replace or make repairs to approval of the Consultant and at no cost to the Owner.
- 1.5.12 Maintain security of areas in which demolition is proceeding by control of access through hoarding, enclosing fences, and barricades during times work is in progress, and by locking hardware otherwise.
- 1.5.13 Prevent spread of dust beyond the demolition area by wetting, or by other approved means, as it accumulates.
- 1.5.14 Keep sidewalks, streets, and highways free of dust and debris from demolition work. Clean up accumulations as they occur.
- 1.5.15 Remove protections and barricades only if and when directed.
- 1.5.16 Supply and installation of protection around existing trees and planting to remain in conformance with Authorities Having Jurisdiction. Immediately repair damage to trees, bench marks, structures, buried and above-ground services, and survey monuments should it occur as a result of this Section.

1.5.17 Be responsible for damages of any kind and making good to the Consultant's approval.

## 1.6 **DUST CONTROL**

1.6.1 Use all means necessary to prevent spread of dust during performance of the Work of this Section by dust control and temporary dust partitions. Thoroughly moisten all surfaces as required to prevent dust from being a nuisance to the public, neighbours and performance of other work on the site. Take precautions to avoid water damage during wetting down operations.

1.6.2 Dustproof partitions shall consist of construction grade wood 38 mm x 92 mm framing from floor to the underside of deck with one layer of 13 mm plywood sheathing covered with sealed and taped 10 mil polyethylene, caulked and sealed around the perimeter of the partition covered by two layers of 16 mm type X gypsum wall board with offset joints taped and filled with two coats of good quality paint - colour to Architects selection.

1.6.3 Dustproof partitions shall be erected outside of school operating hours and shall remain in place until the new addition is Substantially Complete and accepted by the Owner in writing.

1.6.4 Provide sealed dust-proof barriers for all air-handling ductwork entering the place of Work and other openings that could communicate dust from the work place to the adjoining school areas. Remove at the completion of all dust / odour producing Work, thoroughly clean adjacent duct-work etc. from all debris from construction and make good all finishes disturbed by the sealing procedures.

## 1.7 **TRAFFIC FLOW**

1.7.1 Conduct operations in such a manner as not to impede vehicular or pedestrian traffic normal to area adjacent to building or on streets, sidewalks or alleys given access to area or buildings in neighbourhood. Do not impede or create unsafe conditions for the surrounding public / play areas.

1.7.2 Do not place or store materials or equipment in such a way as to obstruct flow of traffic on thoroughfares, streets, sidewalks or space surrounding buildings.

## 2. **PRODUCTS**

### 2.1 **MATERIALS FROM DEMOLITION**

2.1.1 All materials from the demolition and preparatory work shall become the property of the Contractor and be removed from the site unless otherwise mentioned.

2.1.2 On-site burning will not be permitted.

2.1.3 Take over items for demolition and repairs in their condition on date that tender is accepted, irrespective of their condition prior to tendering.

2.1.4 Removal of hazardous substances, where required, shall be carried out in strict accordance with regulations of the authorities governing such substances.

2.1.5 Each trade, upon completion of work shall remove plant, equipment, surplus materials and debris resulting from the work. Any hazardous waste must be removed from the site and are not to be placed in the Owner's trash receptacle.

## 3. **EXECUTION**

### 3.1 **WORKMANSHIP**

3.1.1 **Do not start demolition without the approval of the Board.**

- 3.1.2 Before commencing demolition, have existing mechanical, electrical and other services in the areas being altered, cut off, capped at source, diverted, or removed as required. Protect and maintain services in the existing building without interruption during the periods when they are required for use. The capping or diverting of lines encountered within the area of alteration shall only be carried out within the time periods as directed by the Board's local representative.
- 3.1.3 Provide protection as required to enable existing building and equipment to remain in continuous and normal operation and maintain construction schedule.
- 3.1.4 Furnish all labour, materials, tools, plant and services necessary for or incidental to the work of this Section.
- 3.1.5 Retain and hand over to the Board's representative any items designated as the Board's property.
- 3.1.6 All repairs shall match existing quality.
- 3.1.7 Repairs to sidewalks, curbs, roads, etc. shall be to municipal standards.
- 3.1.8 All existing openings in concrete slabs which become unnecessary due to abandoned services shall be filled with concrete. Concrete repairs shall be neat and flush with exposed surfaces. Roughen sides of openings to provide keying for new concrete.
- 3.2 **PREPARATION**
- 3.2.1 Inspect the site with the Consultant and Board representative and verify the extent and location of items designated for removal, disposal, salvage and items to remain.
- 3.2.2 Locate and protect utilities. Preserve active utilities traversing site in operating condition.
- 3.2.3 Notify and obtain approval of utility companies before starting demolition.
- 3.3 **DEMOLITION**
- 3.3.1 Be responsible to obtain permission to enter, before starting work.
- 3.3.2 Do not use explosives or smashing type of mechanical wrecking devices without Consultants written approval.
- 3.3.3 The limits of demolition, and areas and phases of work, where shown on drawings, are approximate only, and shall be confirmed to the Consultant's approval.
- 3.3.4 Carry out demolition in a systematic manner as necessary to accommodate remedial, reconstruction or new work.
- 3.3.5 Remove items as indicated. Do not disturb items designated to remain in place. Repair and make good items damaged / disrupted by this Work scheduled to remain in place.
- 3.3.6 Remove existing concrete sidewalk and lines, curbs, asphalt, patios, walls, structures, etc. where shown on drawings and where existing work conflicts with new work.
- 3.3.7 In removal of pavements, curbs and gutters:  
a) Square up adjacent surfaces to remain in place by saw cutting or other method approved by Consultant.  
b) Protect adjacent joints and load transfer devices.  
c) Protect underlying and adjacent granular materials.

- 3.3.8 Use equipment and methods of removal and hauling which do not tear, gouge, break, or otherwise damage or disturb pavement to remain.
- 3.3.9 When removing pipes under existing or future pavement area, excavate at least 300 mm. below pipe invert.
- 3.3.10 Provide for suppression of dust generated by the removal process.
- 3.3.11 Remove surfaces to full depth, including granular base courses.
- 3.3.12 Remove surfaces only to extent of private property lines and structures and where shown to facilitate new work.
- 3.3.13 Pavement, structures, curbs, etc. slated for removal which are adjacent to existing pavement to remain, shall be neatly and accurately saw-cut prior to removal.
- 3.3.14 Small pieces of concrete and masonry may be used to back fill with the written permission of the Consultant. Do not use organic or metallic materials for back fill.
- 3.3.15 At the end of each days work, leave site in a safe condition so that no part is in danger of collapse. Do not stack salvaged materials or debris liable to overload any part of the structure.
- 3.3.16 Minimize dust during demolition. Keep dust dampened at all times.
- 3.3.17 Remove organic, metallic, contaminated or dangerous materials from the site and ensure safe disposal.
- 3.3.18 Salvage: items to be salvaged as indicated on drawings.
- 3.3.19 Carefully dismantle items containing materials for salvage and stockpile salvaged materials at locations designated.
- 3.3.20 Sealing: Seal pipe ends and walls of manholes or catch basins as indicated. Securely plug to form watertight seal.
- 3.3.21 Decommission septic, fuel or storage tanks under the most stringent requirements set out by the Ministry of Environment and/or other authority.
- 3.3.22 Service Connections for Removal: Disconnect, cap and seal electrical, telephone, cable TV, sewage, drainage, water and gas lines in accordance with the rules and regulations of the authorities having jurisdiction; employ tradesmen licensed to carry out this work.
- 3.3.23 Service Connections for Retention: Clearly paint, mark and post warning signs on lines to remain in service and promptly repair any damage to maintain active service.
- 3.4 **CLEARING**
- 3.4.1 Clear and remove all debris, asphalt, concrete, rocks, boulders and other useless materials within the project boundaries where necessary for the installation of new work.
- 3.4.2 Burying of useless materials on the site is not permitted.
- 3.4.3 Burning of useless materials will not be permitted.

3.4.4 Disposal of useless materials shall be off site and at the Contractor's expense. The Owner shall not be responsible to provide a disposal site.

### 3.5 **RESTORATION**

3.5.1 Restore areas and existing works outside areas of demolition to match condition of adjacent, undisturbed areas.

### 3.6 **DISPOSAL**

3.6.1 Remove completely from the site all debris resulting from demolition, except for specified salvage and debris used as specified to fill voids below grade.

3.6.2 Remove debris daily, immediately as it accumulates.

3.6.3 Do not overload trucks and otherwise take means to prevent spillage during travel.

3.6.4 Legally dispose of waste materials at certified Waste Management sites and assume all cost of disposal.

3.6.5 Do not sell at site, materials from demolition.

3.6.6 Notify the Owner immediately of any contaminated or dangerous materials.

3.6.7 Dispose of contaminated or dangerous materials immediately, and under the most stringent guidelines set out by the Ministry of Environment and to minimize all dangers.

### 3.7 **COMPLETION AND CLEANING**

3.7.1 Keep sidewalks, roadways, parking lots, streets, and highways free of dust and debris from demolition work. Clean up accumulations as they occur.

3.7.2 Clean exposed surfaces and adjacent areas ready for reconstruction operations.

3.7.3 Remove tools, equipment, trash, dust and dirt from the site of operations and leave in a broom clean condition.

3.7.4 Remove protections, barricades and other temporary construction on completion of demolition, except those to be maintained in place protecting access to open areas below grade and new construction work.

3.7.5 Upon completion of work, remove debris, trim surfaces and leave work site clean.

3.7.6 Sweep remaining surfaces clean of debris resulting from removal operations using rotary power brooms and hand brooming as required.

3.7.7 On completion of the work of this Section, remove all protection. Make good all damage to this work and to adjoining work due to lack of or failure of such protection. Remove from the site all debris, surplus materials, tools, plant and equipment and leave clean and tidy, in a good and workmanlike manner.

3.7.8 When work of this Section is completed in any given area, assume responsibility for protection. Make good any damaged work or broken glass until acceptance of the completed contract by the Owner.

3.7.9 Remove all debris from the site as work progresses on a daily basis.

3.8        **REPAIRS**

- 3.8.1       Repair and make good all property damaged by the Contractor during demolition which was due to negligence on the part of the Contractor at no extra cost to the Contract and to the approval of the Consultant or other Jurisdictional Authority.

END OF SECTION

- 1 General
- 1.1 RELATED SECTIONS
  - .1 Section 04 05 10 - Masonry Mortaring and Grouting.
  - .2 Section 04 05 19 - Masonry Anchorage and Reinforcing.
  - .3 Section 04 05 23 - Masonry Accessories.
  - .4 Section 04 21 00 - Clay Unit Masonry.
  - .5 Section 04 22 00 - Concrete Unit Masonry.
  - .6 Section 05 50 00 - Metal Fabrications.
- 1.2 REFERENCES
  - .1 CAN/CSA-A371-14 (R2019): Masonry Construction for Buildings.
  - .2 CSA S304-14: Design of Masonry Structures.
- 1.3 SAMPLES
  - .1 Submit samples as specified in Section 01 33 00.
  - .2 Samples: As follows:
    - .1 Two samples of each type of masonry unit specified, illustrating colour, texture and extremities of colour range;
    - .2 One sample of each type of masonry reinforcement and tie specified in Section 04 05 19;
    - .3 One sample of each type of masonry accessory specified in Section 04 05 23; and
    - .4 as required for testing purposes.
- 1.4 TEST AND EVALUATION REPORTS
  - .1 Submit test reports as specified in Section 01 33 00.
  - .2 Test Reports: Manufacturer's standard masonry analysis and testing reports, indicating compressive strength, initial rate of absorption, maximum water absorption, maximum saturation coefficient, and density for each type of masonry unit specified; prepared by independent agency.
- 1.5 QUALIFICATIONS
  - .1 Installer: A firm specializing in installing commercial masonry, having minimum 5 years documented experience, and a member of OMCA.
- 1.6 MOCK-UPS
  - .1 Construct mock-up as specified in Section 01 40 00.
  - .2 Mock-Up Panel: A 1 220 x 1 830 mm size mock-up panel, demonstrating veneer cladding types, textures and colours; mortar joint thickness, tooled profiles and colours. Include structural back-up materials, air/vapour barrier membrane materials, through-wall flashing and weephole vents, cavity wall insulation, wall ties and connectors, and movement joint.
  - .3 Report mortar colour loading rate for acceptable panel.
  - .4 Accepted mock-ups will be used as the standard for acceptance of the Work.

.5 Remove and replace installed Product that does not conform to accepted mock-up.

.6 Remove mock-ups from Place of the Work upon Ready-for-Takeover.

#### 1.7 DELIVERY, STORAGE AND HANDLING

.1 Refer to Section 01 60 00.

.2 Deliver Products to Place of the Work in dry condition.

.3 Keep Products dry until use.

.4 Store Products under waterproof cover on pallets or plank platforms held off ground by means of plank or timber skids.

.5 Protect masonry units from damage.

#### 1.8 AMBIENT CONDITIONS

.1 Conform to CAN/CSA-A371.

.2 Provide heated enclosures and heat as necessary during cold weather construction.

.3 Protect freshly laid masonry from drying too rapidly during hot weather, by means of waterproof, non-staining coverings.

### 2 Products

#### 2.1 SOURCE QUALITY CONTROL

.1 Perform shop testing by independent inspection agency as specified in Section 01 40 00.

.2 Refer to individual specification Sections for Product-specific shop testing requirements.

### 3 Execution

#### 3.1 QUALITY OF WORK

.1 Construct masonry plumb, level and true to line, with vertical joints in alignment.

.2 Lay out coursing and bond to achieve correct coursing heights, and continuity of bond above and below openings, with minimum of cutting.

.3 Maintain masonry courses to uniform width.

.4 Lay masonry in full bed of mortar, properly jointed with other work.

.5 Buttering corners of joints, and deep or excessive furrowing of mortar joints are not permitted.

.6 Maintain dry masonry beds and lay only dry masonry units. Do not pre-soak masonry units in cold weather.

.7 Fully bond intersections, and external corners.

.8 Do not use chipped, cracked or otherwise damaged units in exposed and loadbearing masonry walls.

.9 Build in items required to be built into masonry.

.10 Brace door frames to maintain plumb. Fill spaces between frame jambs and masonry with masonry grout.



- .11 Prevent displacement of built-in items during construction. Check plumb, location and alignment frequently, as work progresses.

### 3.2 JOINTING

- .1 Make vertical and horizontal joints equal and of uniform thickness.
- .2 Tooled Joints: Allow joints to set just enough to remove excess water, then tool joints with round jointer to result in a smooth, tightly compressed, uniformly concave profile.
- .3 Flush Joints: Strike flush joints that will be concealed within wall or which will receive a coating of plaster, tile, insulation, resilient base, bituminous foundation protection, or other joint-concealing finish. Do not strike flush mortar joints designated to receive painted or other thin finishes.

### 3.3 CUTTING

- .1 Cut out masonry neatly for recessed or built-in objects.
- .2 Make cuts straight, clean and free from uneven edges.
- .3 Make Good masonry which has cracked or broken as a result of cutting in built-in objects.

### 3.4 PROVISIONS FOR MOVEMENT

- .1 Unless specified or shown otherwise, Provide the following space to accommodate movement:
  - .1 Deflection Space Below Shelf Angles: 10 mm.
  - .2 Between Masonry and Vertical Structural Elements: 10 mm.
  - .3 Between Top of Non-loadbearing Partitions and Structural Elements: 12 mm.
- .2 Fill space with compressible material and seal both sides as specified in Section 07 92 00. Do not use wedges.
- .3 Provide continuous movement control joints, properly sealed with backing rod and joint sealant, as specified in Section 04 05 23.

### 3.5 LOOSE STEEL LINTELS

- .1 Install loose steel lintels.
- .2 Centre lintel over opening width.

### 3.6 TEMPORARY WALL BRACING

- .1 Provide engineered temporary bracing for masonry walls to resist wind pressure and other lateral loads during and after erection until permanent lateral support is in place.

### 3.7 PROTECTING MASONRY

- .1 Refer to Section 01 76 00.
- .2 Keep masonry dry using waterproof, non-staining coverings that extend over walls and down sides sufficient to protect walls from wind-driven rain, until masonry is completed and protected by flashings or other permanent construction.
- .3 Protect masonry and other work from marking and other damage.
- .4 Protect completed work from mortar droppings. Use non-staining coverings.

### 3.8 FIELD QUALITY CONTROL

- .1 Field Inspection: Consultant will inspect installed masonry and reject masonry that is chipped, cracked, or blemished (streaked, stained or otherwise damaged), as described below.
- .2 Unless specified otherwise, masonry will be inspected to be free of chips, cracks or other blemishes on the finished face or front edges of the masonry units exceeding 10 mm or that can be seen from a distance of 3 000 mm. Masonry units supplied with a rusticated face will be inspected for cracks and blemishes only.
- .3 Make Good rejected masonry as directed by Consultant.

### 3.9 TOLERANCES

- .1 Conform to CAN/CSA-A371.

### 3.10 CLEANING

- .1 Clean masonry as work progresses.
- .2 Allow mortar droppings on masonry to partially dry, then remove by means of brushing with a stiff fibre brush.
- .3 Post-Construction Cleaning: Test clean one-half of mock-up panel and leave for one week. Proceed with cleaning operations only if no harmful effects appear, and only after mortar and sealants have properly set and cured.
- .4 Clean masonry as follows:
  - .1 Remove large particles without damaging surface. Saturate masonry with clean water and flush off loose mortar and dirt.
  - .2 Scrub with solution of 25 mL trisodium phosphate and 25 mL household detergent dissolved in 1 Litre of clean water using stiff fibre brushes, then clean off immediately with clean water using hose.
  - .3 Repeat cleaning process as often as necessary to remove mortar and other stains.
- .5 Use alternative cleaning solutions and methods for difficult to clean masonry only after consultation with masonry unit manufacturer.

END OF SECTION

- 1 General
- 1.1 RELATED SECTIONS
  - .1 Section 04 21 00 - Clay Unit Masonry.
  - .2 Section 04 22 00 - Concrete Unit Masonry.
  - .3 Section 08 12 13 - Hollow Metal Frames.
- 1.2 REFERENCES
  - .1 ASTM C207-18: Standard Specification for Hydrated Lime for Masonry Purposes.
  - .2 ASTM C979/C979M-16: Standard Specification for Pigments for Integrally Colored Concrete.
  - .3 CAN/CSA-A179-14: Mortar and Grout for Unit Masonry.
  - .4 CSA A3001-18: Cementitious Materials for Use in Concrete.
  - .5 CSA A3002-18: Masonry and Mortar Cement.
  - .6 CSA S304-14: Design of Masonry Structures.
  - .7 NCMA TEK 3-2A-2005: Grouting Concrete Masonry Walls.
- 1.3 PRODUCT DATA
  - .1 Submit Product data as specified in Section 01 33 00.
  - .2 Product Data: On design mix, indicating Proportion or Property specification method used, required environmental conditions and admixture limitations.
- 1.4 SAMPLES
  - .1 Submit samples as specified in Section 01 33 00.
  - .2 Verification Samples: Two ribbons of mortar, illustrating colour and colour range.
    - .1 Complete upon acceptance, confirmation of site-mixed colour additive proportional to site-mixed batch.
    - .2 Prepare and submit sample colour ribbons for each days work for review of consistency.
- 1.5 FIELD QUALITY CONTROL SUBMITTALS
  - .1 Submit field quality control submittals as specified in Section 01 40 00.
  - .2 Verification Samples: Sample cubes for laboratory testing, to CAN/CSA-A179.
  - .3 Test Reports: Clearly indicating test result data, to CAN/CSA-A179.
- 1.6 DELIVERY, STORAGE AND HANDLING
  - .1 Refer to Section 01 60 00.
  - .2 Deliver Products in original unbroken and undamaged packages with manufacturer's name and brand clearly indicated.
  - .3 Store Products in a weatherproof shed until ready for use.
  - .4 Store or pile sand on a plank platform and protect from dirt and rubbish.
  - .5 Store Products in a manner to prevent deterioration or contamination by foreign materials.

1.7 AMBIENT CONDITIONS

- .1 Maintain materials and surrounding air temperature between 5 degrees C and 50 degrees C prior to, during, and 48 hours after completion of masonry installation.
- .2 Do not use anti-freeze, liquid salts or other substances to lower freezing point of mortar or grout. Conform to CAN/CSA-A179.

2 Products

2.1 MANUFACTURERS

- .1 Manufacturers of cement having Product considered acceptable for use:
  - .1 Essroc.
  - .2 Holcim.
  - .3 Lafarge Construction Materials.
  - .4 St. Marys Cement.
- .2 Manufacturers of hydrated lime having Product considered acceptable for use:
  - .1 Graymont Dolime (OH) Inc.
  - .2 Rockwell Lime Co.
- .3 Manufacturers of dry, plant-batched mortar mixtures having Product considered acceptable for use:
  - .1 Daubois.
  - .2 Graymont Dolime (OH) Inc.
  - .3 King Packaged Materials Company.
- .4 Manufacturers of mortar pigment having Product considered acceptable for use:
  - .1 Bayer Pigments.
  - .2 Elementis Pigments.
  - .3 Interstar.
  - .4 Hamburger Company.
- .5 Substitution Procedures: Refer to Section 01 25 00.

2.2 MATERIALS

- .1 Portland Cement: To CSA A3001, Type GU; Grey colour.
- .2 Masonry Cement: To CSA A3002, Type N.
- .3 Hydrated Lime: To ASTM C207, Type S-Special.
- .4 Mortar Aggregate: To CAN/CSA-A179, natural sand, standard masonry type; clean, dry, protected against dampness, freezing, and foreign matter.
- .5 Grout Coarse Aggregate: To CAN/CSA-A179, maximum 10 mm size; 27 percent by volume.
- .6 Grout Fine Aggregate: To CAN/CSA-A179, clean well graded sharp sand; 54 percent by volume.
- .7 Water: Potable, clean and free of deleterious amounts of acids, alkalies or organic materials.

## 2.3 ADMIXTURES

- .1 Plasticizer: Water reducing type, reducing porosity and absorption to increase bond strength.
- .2 Water Repellent: Mixture of calcium carbonate and hydrous magnesium aluminum silicate powders; eg. Hydrocide Powder by Degussa Building Systems.
- .3 Pigment: To ASTM C979/C979M; liquid-manufactured or natural oxide pigment, colours as selected by Consultant.

## 2.4 MORTAR MIXES

- .1 Mortar for Use with Loadbearing Concrete Unit Masonry: To CAN/CSA-A179, Type S using Property specification method; Portland cement-masonry cement-sand mix, having minimum compressive strength of 8.5 MPa at 28 days; complete with water repellent admixture.
- .2 Mortar for Use with Non-Loadbearing Concrete Unit Masonry: To CAN/CSA-A179, Type N using Property specification method; masonry cement-sand mix, having minimum compressive strength of 3.5 MPa at 28 days; complete with water repellent admixture.
- .3 Mortar for Use with Masonry Veneers: To CAN/CSA-A179, Type N using Proportion specification method; Portland cement-hydrated lime-sand mix, complete with integral colours as selected by Consultant.

## 2.5 MORTAR MIXING

- .1 Thoroughly mix ingredients in proper measured quantities needed for immediate use, to CAN/CSA-A179.
- .2 Pigmented Mortar: Pigment dosage as selected by Consultant, but not to exceed 10 percent of cement content by mass, as defined in ASTM C979/C979M.
- .3 Provide uniformity of mix and colour.
- .4 Take representative samples for testing consistency of strength and colour to CAN/CSA-A179.
- .5 Use mortar within 1-1/2 hours after mixing at temperature of 25 degrees C or higher, or 2-1/2 hours after mixing at temperatures less than 25 degrees C.
- .6 Discard mortars exceeding time limits specified above.

## 2.6 GROUT MIXES

- .1 Grout for Use in Spaces 50 mm or Wider: To CAN/CSA-A179, Coarse Grout using Property Specification method; Portland cement-sand-coarse aggregate mix.
- .2 Grout for Use in Spaces Narrower than 50 mm: To CAN/CSA-A179, Fine Grout using Property Specification method; Portland cement-sand mix,.
- .3 Match grout's 28 day compressive strength to compressive strength of concrete masonry unit being filled.

## 2.7 GROUT MIXING

- .1 Thoroughly mix ingredients accurately in proper measured quantities needed for immediate use, to CAN/CSA-A179.
- .2 Use grout within 1-1/2 hours after mixing.
- .3 Discard grout exceeding time limit specified above.

- 3 Execution
  - 3.1 EXAMINATION
    - .1 Refer to Section 01 71 00.
    - .2 Request Consultant inspection of spaces to be grouted.
  - 3.2 PREPARATION
    - .1 Apply bonding agent to existing concrete surfaces.
    - .2 Plug clean-out holes with masonry units to prevent leakage of grout materials.
    - .3 Brace masonry for wet grout pressure.
    - .4 Install grout dams below voids designated to be filled with grout. Keep dams 25 mm back from faces of units.
    - .5 Remove excess mortar from grout spaces.
  - 3.3 APPLICATION
    - .1 Install mortar as specified in Sections 04 21 00 and 04 22 00.
    - .2 Install grout to NCMA TEK 3-2A.
    - .3 Fill unit cores with grout fill where hollow concrete masonry units are used instead of solid concrete masonry units.
    - .4 Place grout as required to maintain an adequate level of structural bearing surface with no voids and to a depth as indicated on Drawings.
    - .5 Prevent grout from entering acoustically-insulated cores of acoustic concrete masonry units.
  - 3.4 FIELD QUALITY CONTROL
    - .1 Perform inspection and testing of mortar and grout mixes as specified in Section 01 40 00.
    - .2 Test Property specification mortars for compressive strength to CAN/CSA-A179, and as follows:
      - .1 Test three 50 mm cubes at 7 days and three 50 mm cubes at 28 days.
      - .2 Mortar for Concrete Unit Masonry: Perform one test for every 500 m<sup>2</sup> of wall, but not less than one set of tests for each storey height of each building.
    - .3 Test grout for slump and compressive strength to CAN/CSA-A179, and as follows:
      - .1 Slump at Time and Point of Placement: 225 mm, plus or minus 25 mm.
      - .2 Take one set of grout cylinders at least daily for each 20 m<sup>3</sup> of grout poured and whenever the mix design changes.
      - .3 Cylinder Sets: Comprised of minimum three cylinders.
      - .4 Test one cylinder at 7 days and two cylinders at 28 days.
  - 3.5 NON-CONFORMING WORK
    - .1 Make Good portions of the Work constructed with mortar or grout that does not meet specified criteria.
    - .2 Remove and reconstruct affected walls using new Product.

END OF SECTION

## General

### 1.1 RELATED SECTIONS

- .1 Section 04 05 00 - Common Work Results for Masonry.
- .2 Section 04 05 10 - Masonry Mortaring and Grouting.
- .3 Section 04 05 23 - Masonry Accessories.
- .4 Section 04 21 00 - Clay Unit Masonry.
- .5 Section 04 22 00 - Concrete Unit Masonry.
- .6 Section 05 40 00 - Cold-Formed Metal Framing.
- .7 Section 05 50 00 - Metal Fabrications.

### 1.2 REFERENCES

- .1 ASTM A123/A123M-17: Standard Specification for Zinc (Hot-Dip Galvanized) Coatings on Iron and Steel Products.
- .2 ASTM A153/A153M-16a: Standard Specification for Zinc Coating (Hot-Dip) on Iron and Steel Hardware.
- .3 ASTM A240/A240M-20a: Standard Specification for Chromium and Chromium-Nickel Stainless Steel Plate, Sheet, and Strip for Pressure Vessels and for General Applications.
- .4 ASTM A580/A580M-16: Standard Specification for Stainless Steel Wire.
- .5 ASTM A641/A641M-19: Standard Specification for Zinc-Coated (Galvanized) Carbon Steel Wire.
- .6 ASTM A951/A951M-16e1: Standard Specification for Steel Wire for Masonry Joint Reinforcement.
- .7 ASTM A1011/A1011M-18a: Standard Specification for Steel, Sheet and Strip, Hot-Rolled, Carbon, Structural, High-Strength Low-Alloy, High-Strength Low-Alloy with Improved Formability and Ultra-High Strength.
- .8 CSA A370-14 (R2018): Connectors for Masonry.
- .9 CAN/CSA-A371-14 (R2019): Masonry Construction for Buildings.
- .10 CSA G30.18-09 (R2014): Carbon Steel Bars for Concrete Reinforcement.
- .11 CSA S304-14: Design of Masonry Structures.

### 1.3 MOCK-UPS

- .1 Supply Product for construction of mock-up panel as specified in Section 04 05 00.

## 2 Products

## 2.1 MANUFACTURERS

- .1 Manufacturers of horizontal joint reinforcement and anchors having Product considered acceptable for use:
  - .1 Blok-Lok.
- .2 Manufacturers of wall ties having Product considered acceptable for use:
  - .1 Blok-Lok.
  - .2 Fero.
- .3 Substitution Procedures: Refer to Section 01 25 00.

## 2.2 MATERIALS

- .1 Steel Plate: To ASTM A1011/A1011M; galvanized finishes, sizes, and thicknesses as specified below.
- .2 Steel Wire: To ASTM A951/A951M; galvanized finishes and diameters as specified below.
- .3 Stainless Steel Plate: To ASTM A240/A240M, Type 304; sizes and thicknesses as specified below.
- .4 Stainless Steel Wire: To ASTM A580/A580M, Type 304; diameters as specified below.

## 2.3 HORIZONTAL JOINT REINFORCEMENT

- .1 Exterior Wall Horizontal Joint Reinforcement: To CSA A370, Ladder-type, Extra Heavy Duty; hot dipped galvanized steel wire; width to suit concrete masonry unit bed depth; BL-10 by Blok-Lok.
- .2 Interior Wall Horizontal Joint Reinforcement: To CSA A370, as follows:
  - .1 Loadbearing Walls, Multi-Wythe: Ladder-type, Extra Heavy Duty; mill galvanized steel wire; width to suit concrete masonry unit bed depths; BL-12 by Blok-Lok.
  - .2 Loadbearing Walls, Single-Wythe: Ladder-type, Extra Heavy Duty; mill galvanized steel wire; width to suit concrete masonry unit bed depth; BL-10 by Blok-Lok.
  - .3 Non-Loadbearing Walls, Single-Wythe: Ladder-type, Standard Duty; mill galvanized steel wire; width to suit concrete masonry unit bed depth; BL-10 by Blok-Lok.
- .3 Exterior Veneer Bed Joint Reinforcement: To CSA A370, single 4.8 mm OD stainless steel wire.

## 2.4 WALL TIES

- .1 Wall Tie (Steel Stud Back-up): Adjustable, dual component, rod adjustable plate tie system; eg. Fero Side Mounting RAP-Tie, comprised of:
  - .1 Flat Plate: 1.37 mm thick stainless-steel plate; length to suit air space dimension and stud width; complete with a series of five 5.8 mm OD holes punched along the leading edge to receive the V-Tie.
  - .2 V-Tie: 4.76 mm OD stainless steel wire; length to provide placement of tie legs at centerline of veneer.



- .3 Fasteners: Chromium-plated steel self-tapping TEK screws, complete with neoprene O- ring washer and hex washer head; 6.35 mm OD, 19 mm long; minimum two screws per tie.
- .2 Wall Tie (CMU Back-up): Adjustable, dual component, shear connector system; eg. Fero Block Shear Connector, comprised of:
  - .1 Block Plate: 1.61 mm thick stainless-steel plate; length to suit air space and CMU width dimension, less 6 mm; complete with a series of eight 5.8 mm OD holes punched along the leading edge to receive the V-Tie.
  - .2 V-Tie: 4.76 mm OD stainless steel wire; length to provide placement of tie legs at centerline of veneer.
- .3 Wall Tie (Concrete Back-up): Adjustable, dual component, rod adjustable plate tie system; eg. Fero RAP-Tie, comprised of:
  - .1 L-Plate: 1.37 mm thick stainless-steel plate; length to suit air space dimension; complete with a series of five 5.8 mm OD holes punched along the leading edge to receive the V- Tie.
  - .2 V-Tie: 4.76 mm OD stainless steel wire; length to provide placement of tie legs at centerline of veneer.
  - .3 Fastener: Tapcon-style hex head self-tapping screws, complete with blue climaseal coating; 6.35 mm OD, 83 mm long; minimum two screws per tie.
- .4 Wall Tie (Structural Steel Back-up): Adjustable, dual component, rod adjustable plate tie system; suitable for welded attachment; eg. Fero RAP-Tie, comprised of:
  - .1 L-Plate: 1.37 mm thick stainless-steel plate; length to suit air space dimension; complete with a series of five 5.8 mm OD holes punched along the leading edge to receive the V- Tie.
  - .2 V-Tie: 4.76 mm OD stainless steel wire; length to provide placement of tie legs at centerline of veneer.

## 2.5 ACCESSORIES

- .1 Reinforcing Steel: To CSA G30.18, Grade 400R; new billet steel, deformed bars; sizes as indicated on Drawings.
- .2 Strap Anchors: 6.0 mm thick, 38 mm wide steel plate with 50 mm long Z-shaped bends; hot dipped galvanized; lengths to suit application; eg. BLT-11Z by Blok-Lok.
- .3 Anchor-Type Fasteners: To CSA A370, hot dipped galvanized steel, purpose made for substrate.

## 2.6 FINISHES

- .1 Hot Dipped Galvanized Coating: To ASTM A123/A123M and ASTM A153/A153M, Class B2, minimum 458 g/m<sup>2</sup> zinc coating on all surfaces, except as specified below:
  - .1 Strap Anchors: To ASTM A123/A123M, minimum 503 g/m<sup>2</sup> zinc coating on all surfaces.
- .2 Mill Galvanized Coating: To ASTM A641/A641M, Regular; minimum 30 g/m<sup>2</sup> zinc coating on all surfaces.

## 3 Execution

### 3.1 PREPARATION

- .1 Supply metal anchors to the appropriate trades for placement. Direct correct placement.
- .2 Verify that anchorages embedded in concrete or attached to structural steel members are properly placed. Embed anchorages in every second joint.

### 3.2 INSTALLATION

- .1 Install masonry connectors and reinforcement to CSA A370.
- .2 Place horizontal joint reinforcement continuous in every second horizontal joint, with minimum 300 mm lap splices.
- .3 Place horizontal joint reinforcement in first and second horizontal joints above and below openings. Extend 600 mm minimum each side of opening.
- .4 Place horizontal joint reinforcement continuous in first and second joints below top of walls.
- .5 Reinforce joint corners and intersections with strap anchors spaced at 400 mm OC vertically.
- .6 Place horizontal bed joint reinforcement at 200 mm OC vertically in bed joints of stack bonded masonry units.
- .7 Provide reinforcing supported and secured against displacement as indicated on Drawings, and as follows:
  - .1 Maintain minimum clearance of 12 mm from masonry and not less than one bar diameter between bars.
  - .2 Provide two 15M reinforcing bars grouted vertically into CMU cores both sides of masonry openings.
  - .3 Provide clean out openings at the bottom of cores containing vertical reinforcement at each grout lift or pour.
- .8 Grout reinforcing and anchorages into masonry as specified in Section 04 05 10.
- .9 Secure wall ties to structural back-up at maximum 400 x 600 mm OC.
- .10 Secure wall ties to steel stud web using minimum two fasteners.
- .11 Double quantity of wall ties within 200 mm of wall corners, wall openings and along parapet walls.

END OF SECTION

1 General

1.1 RELATED SECTIONS

- .1 Section 04 05 00 - Common Work Results for Masonry.
- .2 Section 04 05 10 - Masonry Mortaring and Grouting.
- .3 Section 04 05 19 - Masonry Anchorage and Reinforcing.
- .4 Section 04 21 00 - Clay Unit Masonry.
- .5 Section 04 22 00 - Concrete Unit Masonry.
- .6 Section 05 50 00 - Metal Fabrications.
- .7 Section 07 21 00 - Thermal Insulation.
- .8 Section 07 21 19.13 - Foamed-in-Place Urethane Insulation.
- .9 Section 07 27 00 - Air Barriers.
- .10 Section 07 62 00 - Sheet Metal Flashing and Trim.
- .11 Section 07 92 00 - Joint Sealants.

1.2 REFERENCES

- .1 ASTM A123/A123M-17: Standard Specification for Zinc (Hot-Dip Galvanized) Coatings on Iron and Steel Products.
- .2 ASTM A153/A153M-16a: Standard Specification for Zinc Coating (Hot-Dip) on Iron and Steel Hardware.
- .3 ASTM A240/A240M-20a: Standard Specification for Chromium and Chromium-Nickel Stainless Steel Plate, Sheet, and Strip for Pressure Vessels and for General Applications.
- .4 ASTM A653/A653M-20: Standard Specification for Steel Sheet, Zinc-Coated (Galvanized) or Zinc-Iron Alloy-Coated (Galvannealed) by the Hot-Dip Process.
- .5 BIA Technical Note on Brick Construction 18A: Accommodating Expansion of Brickwork.
- .6 CAN/CSA-A371-14 (R2019): Masonry Construction for Buildings.
- .7 NCMA TEK 10-2C-2010: Control Joints for Concrete Masonry Walls - Empirical Method.

1.3 MOCK-UPS

- .1 Supply Product for construction of mock-up as specified in Section 04 05 00.

2 Products

2.1 MATERIALS

- .1 Flexible Membrane Flashing: 1.0 mm thick self-adhering SBS rubberized asphalt membrane with cross-laminated HDPE top surface, sheet width to suit application; eg. Bakor Blueskin TWF by Henry Company Canada.
- .2 Metal Drip Edge Flashing: To ASTM A240/A240M, Type 316; 0.61 mm thick stainless-

steel sheet.

- .3 Flashing Tape: 75 mm wide, self-adhesive sealing tape; eg. X-Seal Tape by Blok-Lok.
- .4 Cavity Firestops: To ASTM A240/A240M, Type 316; 1.2 mm thick stainless-steel sheet.
- .5 Mortar Dropping Control Device: Purpose made open weave nylon and polyester mesh, top hat profile, complete with insect barrier.
- .6 Weep Vent: Open weave polyester mesh complete with insect barrier, size to suit mortar joint width and depth; colour as selected by Consultant.
- .7 Cavity Wall Filler: To ASTM A240/A240M, Type 316; 1.2 mm thick stainless-steel sheet.
- .8 Nailing Inserts: To ASTM A653/A653M, Commercial Steel (CS), Types A, B, and C; 0.61 mm thick galvanized sheet steel inserts for setting in mortar joints.
- .9 Primer: As recommended by sheet membrane manufacturer.
- .10 Compressible Filler: Closed cell neoprene; eg. Neoprene Sponge by Blok-Lok.
- .11 Building Paper: No. 15 asphalt saturated felt.
- .12 Joint Sealant: Exterior weatherseal sealant, Type SEAL-EXT as specified in Section 07 92 00.

## 2.2 FINISHES

- .1 Galvanized Coating on Steel Components: To ASTM A123/A123M, Z275 hot dipped zinc alloy coating.
- .2 Galvanized Coating on Steel Hardware: To ASTM A153/A153M, Class B2 hot dipped zinc alloy coating.
- .3 Galvanized Coating on Steel Sheet: To ASTM A653/A653M, Z275 hot dipped zinc alloy coating.

## 3 Execution

### 3.1 PREPARATION

- .1 Apply primer to porous surfaces scheduled to receive self-adhering sheet membranes.

### 3.2 INSTALLATION

- .1 Install vertical cavity wall fillers at external corners to prevent wind driven moisture from crossing cavity. Seal filler to outer wythe with joint sealant.
- .2 Install nailing inserts in mortar joints at 400 mm OC each way, for attachment of wall strapping.
- .3 Provide vertical cavity firestops where indicated on Drawings, up to maximum 9 000 mm OC.
- .4 Provide horizontal cavity firestops at maximum 20 000 mm OC.
- .5 Provide mortar dropping control devices at base of wall cavities.
- .6 Provide weep vents in head joints, immediately above through-wall flashing membranes, spaced at maximum 800 mm OC.

- .7 Provide weep vents in head joints, along the top of wall cavities, spaced at maximum 800 mm OC.

### 3.3 FLASHING

- .1 Provide flashings in masonry to CAN/CSA-A371.
- .2 Install flashings under exterior masonry walls bearing on foundation walls or slabs; shelf angles, and steel lintel angles at wall openings, and as indicated on Drawings.
- .3 In double-wythe masonry walls and masonry veneers, carry flashings from front edge of masonry, under outer wythes, then up backing not less than 150 mm, and as follows:
  - .1 Masonry Backing: Embed flashing 25 mm in joint.
  - .2 Concrete Backing: Insert flashing into reglets and seal joint.
  - .3 Framed and Sheathed Backing: Secure flashing to sheathing behind air barrier.
- .4 Lap joints 150 mm and seal watertight.
- .5 Form flashing over openings with end dams at both ends to prevent water from travelling horizontally past the flashing ends.
- .6 Return horizontal base flashing a minimum of 100 mm around corner to overlap abutting flashing. Seal watertight.
- .7 Connect flexible membrane flashing to metal drip edge flashing within wall construction. Extend metal drip edge flashing 10 mm beyond face of masonry veneer.

### 3.4 MOVEMENT AND CONTROL JOINTS

- .1 Provide movement joints in masonry veneers to BIA Technical Note on Brick Construction 18A.
  - .1 Form movement joints by leaving head joints between stacked units void of mortar and reinforcing.
  - .2 Provide compressible filler in joint, set back from face to accommodate application of backer rod and joint sealant.
  - .3 Seal movement joints as specified in Section 07 92 00.
- .2 Provide control joints in concrete unit masonry walls and partitions to NCMA TEK 10-2C.
  - .1 Form control joints by installing a building paper bond breaker fitted to one side of the hollow contour of the block end.
  - .2 Fill the created core solid with grout.
  - .3 Rake joint at exposed faces to accommodate application of backer rod and joint sealant.
  - .4 Seal control joints as specified in Section 07 92 00.
- .3 Do not continue horizontal joint reinforcing across movement and control joints.
- .4 Size movement and control joints for sealant performance as specified in Section 07 92 00.

### 3.5 PROTECTION

- .1 Protect flashings from mortar droppings.

END OF SECTION

1 General

1.1 RELATED SECTIONS

- .1 Section 04 05 00 - Common Work Results for Masonry.
- .2 Section 04 05 10 - Masonry Mortaring and Grouting.
- .3 Section 04 05 19 - Masonry Anchorage and Reinforcing.
- .4 Section 04 05 23 - Masonry Accessories.
- .5 Section 04 21 00 - Clay Unit Masonry.
- .6 Section 05 50 00 - Metal Fabrications.
- .7 Section 07 21 00 - Thermal Insulation.
- .8 Section 07 21 19.13 - Foamed-in-Place Urethane Insulation.
- .9 Section 07 27 00 - Air Barriers.
- .10 Section 07 62 00 - Sheet Metal Flashing and Trim.
- .11 Section 07 92 00 - Joint Sealants.
- .12 Section 08 12 13 - Hollow Metal Frames.
- .13 Section 08 44 13 - Glazed Aluminum Curtain Wall.
- .14 Section 08 51 13 - Aluminum Windows.
- .15 Section 09 90 00 - Painting and Coating.

1.2 REFERENCES

- .1 ASTM C331/C331M-17: Standard Specification for Lightweight Aggregates for Concrete Masonry Units.
- .2 CSA A165 SERIES-14 (R2019): CSA Standards on Concrete Masonry Units.
- .3 CAN/CSA-A371-14 (R2019): Masonry Construction for Buildings.
- .4 CSA S304-14: Design of Masonry Structures.

1.3 SOURCE QUALITY CONTROL SUBMITTALS

- .1 Submit source quality control samples as specified in Section 01 40 00.
- .2 Verification Samples: To CSA S304.

1.4 QUALIFICATIONS

- .1 Manufacturers: A firm specializing in manufacturing concrete masonry units, having minimum 5 years documented experience, and a member of CCMFA.

1.5 MOCK-UPS

- .1 Supply Product for construction of mock-up panel as specified in Section 04 05 00.

1.6 DELIVERY, STORAGE AND HANDLING

- .1 Refer to Section 04 05 00.

1.7 AMBIENT CONDITIONS

- .1 Environmental Requirements: As specified in Section 04 05 00.

2 Products

2.1 MANUFACTURERS

- .1 Manufacturers of decorative concrete masonry units having Product considered acceptable for use:
  - .1 Permacon
  - .2 Brampton Brick.
  - .3 Day & Campbell Ltd.
  - .4 Richvale York Block Inc.
- .2 Substitution Procedures: Refer to Section 01 25 00.

2.2 MATERIALS

- .1 Concrete Masonry Units - Normal Weight (CMU): To CSA A165.1, using N aggregate; 190 mm face height, 390 mm face length, bed depth as indicated on Drawings; solid factory-finished ends with bull nosed corners for use at exposed wall corners, special shapes as required; types where indicated on Drawings, as follows:
  - .1 Hollow: Types H/15/A/M, H/20/A/M and H/30/A/M.
  - .2 Solid (75 percent): Types S/15/A/M, S/20/A/M and S/30/A/M.
  - .3 Solid (100 percent): Types S<sub>f</sub>/15/A/M, S<sub>f</sub>/20/A/M and S<sub>f</sub>/30/A/M.
- .2 Concrete Masonry Units - Lightweight (CMU-LWT): To CSA A165.1, using L<sub>2</sub>20S slag aggregate to ASTM C331/C331M; 190 mm face height, 390 mm face length, bed depth as indicated on Drawings; solid factory-finished ends with bull nosed corners for use at exposed wall corners, special shapes as required; types where indicated on Drawings, as follows:
  - .1 Hollow: Types H/15/C/M, H/20/C/M and H/30/C/M.
  - .2 Solid (75 percent): Types S/15/C/M, S/20/C/M and S/30/C/M.
  - .3 Solid (100 percent): Types S<sub>f</sub>/15/C/M, S<sub>f</sub>/20/C/M and S<sub>f</sub>/30/C/M.

2.3 ACCESSORIES

- .1 Mortar and Grout: As specified in Section 04 05 10.
- .2 Dry Pack Grout: Pre-mixed composition of non-metallic aggregate and cement with sufficient water to maintain its shape when made into a bar by hand and capable of attaining compressive strength of 35 MPa at 28 days.
- .3 Horizontal Joint Reinforcement: As specified in Section 04 05 19.
- .4 Reinforcing Steel: As specified in Section 04 05 19.
- .5 Wall Ties: As specified in Section 04 05 19.
- .6 Strap Anchors: As specified in Section 04 05 19.
- .7 Masonry Accessories: As specified in Section 04 05 23.

2.4 SOURCE QUALITY CONTROL

- .1 Perform laboratory testing of concrete masonry units, as specified in Section 01 40 00.
- .2 Conduct compressive strength tests and water absorption tests to CSA S304.

3 Execution

3.1 PREPARATION

- .1 Install dry-pack grout between masonry and prestressed hollow-core concrete slabs where slabs are parallel to loadbearing masonry walls.

3.2 INSTALLATION

- .1 Place masonry to lines and levels indicated, as specified in Section 04 05 00.
- .2 Except as specified below, lay concrete masonry units in half-running bond pattern.
- .3 Maintain 10 mm wide mortar joints in both directions.
- .4 Provide purpose made pilaster units, 90 and 45 degree corner return units, bullnose units, bond beam units, lintel units as required.
- .5 Provide bullnose concrete masonry units at all exposed corners, except at the first course at floor level and at the corresponding course located at the ceiling level.
- .6 Fully bond intersections, and external corners.
- .7 Extend and laterally support non-loadbearing partitions to underside of structural deck above. Maintain a minimum deflection space at the top of partitions as follows:
  - .1 Partition parallel to structural assembly: 44 mm.
  - .2 Partition perpendicular to structural member: 19 mm.
  - .3 Structural member penetrates partition: 19 mm.
  - .4 Ducts or piping supported from structural assembly that penetrate the partition: 19 mm.
  - .5 Fill deflection space with mineral fibre sound attenuating insulation.
- .8 Place horizontal joint reinforcement as specified in Section 04 05 19.
- .9 Install masonry flashings and accessories as specified in Section 04 05 23.
- .10 Install loose steel lintels as specified in Section 04 05 00
- .11 Install reinforced unit masonry lintels over openings where steel or precast concrete lintels are not scheduled. Construct lintels using grout fill and reinforcing. Maintain minimum 200 mm bearing on each side of opening.
- .12 Reinforce bond beams and pilasters as indicated on Drawings. Place and consolidate grout fill without disturbing reinforcing
- .13 At bearing points, fill masonry cores with grout minimum 300 mm from opening
- .14 Provide vertical and horizontal movement control joints as specified in Section 04 05 23
- .15 Ensure cores of acoustical concrete masonry units remain free of mortar to maintain sound transmission and noise reduction capabilities.

3.3 TOLERANCES

- .1 Variation from Unit to Adjacent Unit:  $\leq 1.5$  mm.
- .2 Variation of Joint Thickness:  $< 3$  mm per metre.



### 3.4 FIELD QUALITY CONTROL

- .1 Refer to Section 01 40 00.
- .2 Consultant Inspection: Consultant will inspect completed masonry walls and will reject walls that have chipped, cracked, or blemished (streaked, stained or otherwise damaged) finished surfaces, as described below.
  - .1 Masonry walls will be inspected to be free of chips, cracks or other blemishes on the finished face or front edges exceeding 10 mm or that can be seen from a distance of 3 000 mm.
  - .2 Masonry shall exhibit a texture approximately equal to the approved sample when viewed under diffused daylight illumination from a distance of 6 000 mm.
  - .3 Minor chipping resulting from shipment and delivery shall not be grounds for rejection. Minor chips shall not be obvious under diffused daylight illumination from a distance of 6 000 mm.
  - .4 Crazeing and efflorescence will not be cause for rejection.
- .3 Make Good rejected Products as directed by consultant.

### 3.5 CLEANING

- .1 Clean masonry as specified in Section 04 05 00.

### 3.6 PROTECTION

- .1 Protect concrete masonry units from damage resulting from subsequent construction operations. Refer to Section 04 05 00.
- .2 Remove protection materials upon Ready-for-Takeover, or when risk of damage is no longer present

END OF SECTION

1 General

1.1 RELATED SECTIONS

- .1 Section 03 30 00 - Cast-In-Place Concrete.
- .2 Section 04 05 19 - Masonry Anchorage and Reinforcing.
- .3 Section 04 22 00 - Concrete Unit Masonry.
- .4 Section 06 16 43 - Gypsum Sheathing.
- .5 Section 06 16 63 - Cementitious Sheathing.
- .6 Section 07 21 00 - Thermal Insulation.
- .7 Section 07 21 19.13 - Foamed-in-Place Urethane Insulation.
- .8 Section 07 26 00 - Vapour Retarders.
- .9 Section 07 27 36 - Sprayed Foam Air Barrier.
- .10 Section 07 42 13 - Metal Wall Panels.
- .11 Section 07 42 43 - Composite Wall Panels.
- .12 Section 07 42 93.23 - Linear Metal Soffits.
- .13 Section 08 12 13 - Hollow Metal Frames.
- .14 Section 08 41 13 - Aluminum-Framed Entrances and Storefronts.
- .15 Section 08 44 13 - Glazed Aluminum Curtain Wall.
- .16 Section 08 51 13 - Aluminum Windows.
- .17 Section 09 21 16 - Gypsum Board Assemblies.

1.2 DEFINITIONS

- .1 Camber: Deviation from straightness of a member or any portion of a member with respect to its major axis.
- .2 Sweep: Deviation from straightness of a member or any portion of a member with respect to its minor axis.

1.3 REFERENCES

- .1 ASTM A307-21: Standard Specification for Carbon Steel Bolts, Studs, and Threaded Rod 60 000 PSI Tensile Strength.
- .2 ASTM A563/A563M-21a: Standard Specification for Carbon and Alloy Steel Nuts (Inch and Metric).
- .3 ASTM A653/A653M-20: Standard Specification for Steel Sheet, Zinc-Coated (Galvanized) or Zinc-Iron Alloy-Coated (Galvannealed) by the Hot-Dip Process.
- .4 ASTM A792/A792M-21a: Standard Specification for Steel Sheet, 55% Aluminum-Zinc Alloy-Coated by the Hot-Dip Process.
- .5 ASTM C955-18e1: Standard Specifications for Cold-Formed Steel Structural Framing Members.

- .6 ASTM C1007-20: Standard Specification for Installation of Load-Bearing (Transverse and Axial) Steel Studs and Related Accessories.
  - .7 ASTM C1513-18: Standard Specification for Steel Tapping Screws for Cold-Formed Steel Framing Connections.
  - .8 ASTM F436/F436M-19: Standard Specification for Hardened Steel Washers Inch and Metric Dimensions.
  - .9 CAN/CGSB-7.1-98: Lightweight Steel Wall Framing Components.
  - .10 CSA S16-14: Design of Steel Structures.
  - .11 CSA S136-16: North American Specification for the Design of Cold-Formed Steel Structural Members.
  - .12 CSA S304-14: Design of Masonry Structures.
  - .13 CSA W47.1:19: Certification of Companies for Fusion Welding of Steel.
  - .14 CSA W55.3-08 (R2018): Certification of Companies for Resistance Welding of Steel and Aluminum.
  - .15 CSA W59-18: Welded Steel Construction.
  - .16 CAN/ULC-S101-14 (REV1): Standard Method of Fire Endurance Tests of Building Construction and Materials.
- 1.4 PRODUCT DATA
- .1 Submit Product data as specified in Section 01 33 00.
  - .2 Product Data: Manufacturer's standard data sheets, indicating mechanical fasteners, indicating sizes, load capacities and type of corrosion protection.
- 1.5 SHOP DRAWINGS
- .1 Submit Shop Drawings as specified in Section 01 33 00.
  - .2 Shop Drawings: Project-specific drawings, showing both design and installation requirements, and illustrating:
    - .1 Materials, sizes, locations, thicknesses exclusive of coating, and coatings.
    - .2 Connection details for attaching framing to itself and for attachment to structure. Show splice details where permitted.
    - .3 Dimensions, openings, requirements of related work and critical installation procedures. Show temporary bracing required for erection purposes.
    - .4 Design loads.
    - .5 Engineering calculations or data verifying capacity of framing members, including masonry connectors if specified, and ability of assemblies to meet design criteria.
  - .3 Shop Drawings must be stamped, signed, and dated by fabricator's design engineer.
- 1.6 SAMPLES
- .1 Submit samples as specified in Section 01 33 00.
  - .2 Verification Samples: Upon request, submit representative pieces of framing component parts including mechanical fasteners if used.
- 1.7 TEST AND EVALUATION REPORTS
- .1 Submit mill test reports as specified in Section 01 40 00.

- .2 Mill Test Reports: Five certified copies, covering chemical and mechanical properties, and coating designation of steel.
- 1.8 FIELD QUALITY CONTROL SUBMITTALS
  - .1 Submit test and inspection reports as specified in Section 01 40 00.
  - .2 Field Quality Control Reports: Manufacturer's field review and inspection reports.
  - .3 Independent Test Reports: Summary of inspection and test findings conducted by independent testing agency.
- 1.9 QUALIFICATIONS
  - .1 Fabricator's Design Engineer: A professional structural engineer experienced with designing, fabricating and erecting cold-formed metal framing assemblies, and licenced to practice at Place of the Work.
  - .2 Installers: A firm specializing in erecting cold-formed metal framing systems, having minimum 10 years documented experience, and a member of CSSBI.
  - .3 Welders: Workers certified by CWB to CSA W47.1 and CSA W55.3; and qualified for base material types and thicknesses being welded.
- 1.10 DELIVERY STORAGE AND HANDLING
  - .1 Refer to Section 01 60 00.
  - .2 Store Products protected from conditions that may cause physical damage or corrosion.
  - .3 Handle and lift prefabricated panels carefully to avoid permanent distortion to any member or collateral material.
- 2 Products
- 2.1 MANUFACTURERS
  - .1 Manufacturers having Products considered acceptable for use:
    - .1 Bailey Metal Products.
    - .2 Dietrich Metal Framing.
    - .3 MiTek Canada Inc.
  - .2 Substitution Procedures: Refer to Section 01 25 00.
- 2.2 DESCRIPTION
  - .1 Lateral Loadbearing Vertical Framing: Comprised of:
    - .1 Wall studs subjected to lateral loads (no axial loads other than self-weight and the weight of applied finishes).
    - .2 Steel bridging.
    - .3 Top and bottom track.
    - .4 Lintel, sill and jamb members for wall openings.
    - .5 Stud, bridging and track connections.
    - .6 Top and bottom connections to main structure including anchor clip angles, through-bolts and epoxy bolts, and detailing to accommodate floor or roof deflections.
  - .2 Loadbearing Horizontal Framing: Comprised of:
    - .1 Roof rafters and joists.
    - .2 Headers and trimmers for floor or roof openings.
    - .3 Bridging.

- .4 Closure channels.
- .5 Connections including web stiffeners.

## 2.3 DESIGN AND PERFORMANCE CRITERIA

- .1 Base design on Limit States Design principles using factored loads and resistances.
- .2 Loads and load factors shall be in accordance with applicable regulatory requirements.
- .3 For wind load calculations, the reference velocity pressure,  $q$ , shall be based on a 1 in 50 probability of being exceeded in any one year for strength design and for deflection.
- .4 Determine resistance and resistance factors in accordance with applicable regulatory requirements and CSA S136.
- .5 Conform to requirements of fire rated assemblies tested to CAN/ULC-S101. Provide fire resistance ratings as indicated on Drawings.
- .6 Member depths are shown on Drawings. Adjust material thicknesses and spacings, as required by design criteria. Use greater or lesser depths only if approved by Consultant.
- .7 Space studs at maximum 400 mm OC. Use lesser spacings if required by design criteria.
- .8 Space roof trusses and joists as noted on Drawings. Use lesser spacings if required by design criteria.
- .9 For studs, track, and joists, conform to minimum design thicknesses listed below. Use greater design thicknesses if required by design criteria.
  - .1 64 mm Width: 0.84 mm thick.
  - .2 92 mm Width: 0.84 mm thick.
  - .3 102 mm Width: 0.84 mm thick.
  - .4 140 mm Width: 0.84 mm thick.
  - .5 152 mm Width: 0.84 mm thick.
  - .6 184 mm Width: 0.91 mm thick.
  - .7 203 mm Width: 1.12 mm thick.
  - .8 235 mm Width: 1.22 mm thick.
  - .9 254 mm Width: 1.52 mm thick.
  - .10 286 mm Width: 1.52 mm thick.
  - .11 305 mm Width: 1.52 mm thick.
  - .12 356 mm Width: 1.91 mm thick.
- .10 For wall studs supporting brick veneer, minimum design thickness exclusive of coating shall be the greater of the design thicknesses listed above or 1.12 mm.
- .11 Minimum design thickness for bridging channel shall be 1.22 mm for studs and 1.52 mm for joists. Use greater bridging channel design thickness if required by design criteria.
- .12 Minimum design thickness for clip angles shall be 1.52 mm for studs and 1.91 mm for joists. Use greater clip angle thickness if required by design criteria.
- .13 Maximum flexural deflections under specified live or wind loads shall conform to:
  - .1 Design loadbearing vertical framing supporting masonry veneer to CSA S304 with lateral stud deflections limited to  $L/720$ .
  - .2 Design loadbearing vertical framing supporting other finishes to limit lateral deflections to  $L/360$ .
  - .3 Design loadbearing horizontal framing to limit deflection to  $L/360$ .
  - .4 Building Sway (due to all effects):  $1/400$  of building height or  $1/500$  of storey height.

- .14 For lateral loadbearing vertical framing:
  - .1 Design connections to accommodate vertical deflection movement of structure, frame shortening and vertical tolerances without imposing axial loads onto framing. Leave a minimum gap of 12 mm. Larger gaps may be required to accommodate structural movement. Coordinate with Consultant.
  - .2 Limit free play and movement in connections perpendicular to plane of framing to plus or minus 0.5 mm relative to building structure.
- .15 Design cold-formed metal framing components and assemblies to accommodate specified erection tolerances of structure.
- .16 Design bridging to prevent member rotation and member translation perpendicular to minor axis. Provide for secondary stress effects due to torsion between lines of bridging. Do not rely on collateral sheathing to help restrain member rotation and translation perpendicular to minor axis.
- .17 Design and Provide bridging as follows:
  - .1 Lateral Loadbearing Vertical Framing: 1 500 mm OC maximum.
  - .2 Loadbearing Horizontal Framing: 2 100 mm OC maximum.
  - .3 Space bridging at equal intervals over the span length of the member. Closer spacings may be required to satisfy structural requirements.
- .18 Design anchorage and splice details for bridging.
- .19 Design for local loading due to anchorage of cladding and interior wall mounted fixtures where shown.
- .20 Connect cold-formed metal framing members by bolting, welding or screwing.
- .21 Provide lintel, sill and jamb members and connections in stud walls to frame openings larger than 100 mm in any dimension.
- .22 Provide headers and trimmers and connections in joist assemblies to frame openings larger than 100 mm in any dimension.

## 2.4 MATERIALS

- .1 Steel: To CSA S136; identified on Shop Drawings as to specification, grade, mechanical properties, and coating type and thickness.
- .2 Machine Bolts: To ASTM A307, Grade A; galvanized.
- .3 Nuts: To ASTM A563/A563M, Grade A, Hex Style; carbon and alloy steel, galvanized.
- .4 Washers: To ASTM F436/F436M, Type 1 for interior applications, Type 3 for exterior applications; galvanized hardened steel washers; circular, bevelled and clipped types as required.
- .5 Screws: To ASTM C1513; galvanized steel, self-tapping type.
- .6 Welding Materials: To CSA W59.
- .7 Welding Electrodes: 480 MPa minimum tensile strength series; e.g. E480XX or ER480S-X.
- .8 Touch-up Paint: Zinc-rich, ready-mixed paint.

## 2.5 MANUFACTURED UNITS

- .1 Loadbearing Steel Studs, Joists, Tracks, and Bracing: To ASTM C955; finishes, sizes and thicknesses as identified on accepted Shop Drawings.

## 2.6 FABRICATION

- .1 Except as noted herein, fabricate wall framing components to CAN/CGSB-7.1 and in accordance with accepted Shop Drawings.
- .2 Where specified, Provide cut-outs centred in webs of members to accommodate services and though-the-knockout style bridging. Unreinforced cut-outs shall be limited to following dimensions. Limit distance from centreline of last unreinforced cut-out to end of member to be not less than 300 mm. Consider effect of cut-outs on strength and stiffness of members.
  - .1 92 mm and 102 mm Deep Members
    - .1 Perpendicular to Length of Member: 40 mm.
    - .2 Parallel to Length of Member: 105 mm.
    - .3 Centre to Centre Spacing: 600 mm.
  - .2 152 mm Deep Members
    - .1 Perpendicular to Length of Member: 65 mm.
    - .2 Parallel to Length of Member: 115 mm.
    - .3 Centre to Centre Spacing: 600 mm.
- .3 Length tolerances for members:
  - .1 Tracks: None.
  - .2 Lateral Loadbearing Vertical Framing: Plus or minus 3 mm.
  - .3 Loadbearing Horizontal Framing: Plus or minus 3 mm.
- .4 Cross sectional geometry tolerances for members shall conform to:
  - .1 Member Depth: Minus 1 mm, plus 2 mm.
  - .2 Flange depth: Minus 1 mm, plus 2 mm; minimum 31 mm width.
  - .3 Lip Length: Plus 4 mm.
  - .4 Thickness: To CSA S136.
  - .5 Corner Angles: Plus or minus 3 degrees.
- .5 Mark steel thickness, exclusive of coating, on each member by embossing, stamping with indelible ink or by colour coding.

## 2.7 FINISHES

- .1 Galvanized Coating on Sheet Steel: To ASTM A653/A653M, Z275 hot dipped zinc alloy coating.
- .2 Galvalumed Coating on Sheet Steel: To ASTM A792/A792M, AZM150 hot dipped aluminum-zinc alloy coating.
- .3 Concrete Anchors: Minimum zinc coating thickness of 0.008 mm. Other coatings providing equal or better corrosion protection may be used.
- .4 Powder-actuated and Low Velocity Fasteners: Minimum zinc coating thickness of 0.008 mm. Other coatings providing equal or better corrosion protection may be used.

## 3 Execution

### 3.1 FASTENERS AND WELDS

- .1 Ensure connected parts are in contact. Provide clamping before welding or installing screws as required.
- .2 Welds: To CSA S136, CSA W59 and ANSI/AWS D1.3, as applicable.
- .3 For material less than 3 mm thick, Shop Drawings may show nominal weld leg sizes. For such material, effective throats of welds shall not be less than thickness of thinnest connected part.

- .4 Sheet metal screws shall be of minimum diameter indicated on accepted Shop Drawings, but not less than #8.
- .5 Penetration of Sheet Metal Screws Beyond Joined Materials: Not less than three exposed threads.
- .6 Sheet metal screw thread types, drilling capability and installation shall conform to manufacturer's recommendations.
- .7 Provide sheet metal screws with low profile heads where covered by sheathing materials.
- .8 Install concrete anchors in accordance with manufacturer's recommendations.

### 3.2 ERECTION

- .1 Erect cold-formed metal framing to ASTM C1007.
- .2 Methods of construction may be either piece by piece (stick-built) or by fabrication into panels (panelized) either on- or off-site.
- .3 Erect cold-formed metal framing true and plumb within specified tolerances.
- .4 Employ temporary bracing wherever necessary to withstand loads to which structure may be subject during erection and subsequent construction. Leave temporary bracing in place as long as required for safety and integrity of structure. During construction, ensure margin of safety exists in uncompleted structure consistent with requirements of applicable regulatory requirements and CSA S136.
- .5 Seat studs into top and bottom tracks. Do not allow gap between end of stud and web of track to exceed 4 mm.
- .6 Align adjacent or abutting members in same plane to within plus or minus 0.5 mm.
- .7 Space studs within 3 mm either direction of design spacing. Cumulative error in spacing shall not exceed requirements of finishing materials.
- .8 Align web cut-outs in studs and joists as required for installation of through-the-knockout style bridging and services.
- .9 Take field measurements necessary to ensure proper fit of members.
- .10 Use either saws or shears to cut members. Do not torch cut material.
- .11 Reinforce cut-outs when distance from centre line of cut-out to end of member is less than 300 mm. Submit reinforcing detail to Consultant for approval.
- .12 Locate loadbearing horizontal framing members, and their end stiffeners, directly over axial loadbearing building elements. Alternately, Provide a load distribution member to transfer loads. Do not use cold-formed metal track as a load distribution member.
- .13 Replace members with localized damage.
- .14 Unless a closer spacing is shown on accepted Shop Drawings, anchor top and bottom tracks securely to structure at maximum 800 mm OC. Place one additional anchor within 100 mm of end of each piece of track and additionally as required by accepted Shop Drawings.
- .15 Install additional vertical framing members at abutting walls, openings, terminations against other materials and on each side at corners unless explicitly detailed otherwise on accepted Shop Drawings.
- .16 Insulate jamb and header assemblies that may become inaccessible after installation. Use self-expanding foam sealant as specified in Section 07 27 36.



### 3.3 TOLERANCES

- .1 Plumbness: 1/500th of member length.
- .2 Out-of-Straightness: Including camber and sweep:
  - .1 Vertical Framing: 1/1000th of member length.
  - .2 Joists: 1/1000th of member length.
  - .3 Track: Camber not to exceed 1/1000th of member length.

### 3.4 FIELD QUALITY CONTROL

- .1 Fabricator's design engineer will undertake periodic field review during construction and shall submit reports as described above.
- .2 Fabricator's Design Engineer Review: Include review of mill tests reports, welded and screwed connections, connections to main structure, member sizes, location and material thickness, coating thickness, erection tolerances, and field cutting.
- .3 Additional field inspection and testing will be conducted by independent testing and inspection agency, as specified in Section 01 40 00.
- .4 Independent inspection and testing will include:
  - .1 Checking mill test reports are properly correlated to materials.
  - .2 Sampling fabrication and erection procedures for general conformity to specified requirements.
  - .3 Checking welding conforms to Contract Documents.
  - .4 Checking fabricated members against specified member geometries.
  - .5 Visual inspection of welded connections including sample checking of joint preparation and fit-up.
  - .6 Sample checking of screwed and bolted joints.
  - .7 Sample checking tolerances are not exceeded during fit-up or erection.
  - .8 Additional inspection and testing of welded connections as required by CSA W59.
  - .9 General inspection of field cutting and alterations required by other Sections.
  - .10 Submission of reports to Consultant, Contractor and authorities having jurisdiction; covering work inspected with details of discovered deficiencies.

### 3.5 ADJUSTING

- .1 Touch-up welds and coatings damaged by welding with zinc rich paint.
- .2 Prior to touch-ups, prepare surface in accordance with paint manufacturer's recommendations.

END OF SECTION

1 General

1.1 RELATED SECTIONS

- .1 Section 03 30 00 - Cast-in-Place Concrete.
- .2 Section 04 22 00 - Concrete Unit Masonry.
- .3 Section 09 90 00 - Painting and Coating.

1.2 REFERENCES

- .1 AAMA 611-14: Voluntary Specification for Anodized Architectural Aluminum.
- .2 AAMA 2605-17a: Voluntary Specification, Performance Requirements and Test Procedures for Superior Performing Organic Coatings on Aluminum Extrusions and Panels (With Coil Coating Appendix).
- .3 ASTM A123/A123M-17: Standard Specification for Zinc (Hot-Dip Galvanized) Coatings on Iron and Steel Products.
- .4 ASTM A153/A153M-16a: Standard Specification for Zinc Coating (Hot-Dip) on Iron and Steel Hardware.
- .5 ASTM A240/A240M-20a: Standard Specification for Chromium and Chromium-Nickel Stainless Steel Plate, Sheet, and Strip for Pressure Vessels and for General Applications.
- .6 ASTM A269/A269M-15a(2019): Standard Specification for Seamless and Welded Austenitic Stainless Steel Tubing for General Service.
- .7 ASTM A276/A276M-17: Standard Specification for Stainless Steel Bars and Shapes.
- .8 ASTM A307-21: Standard Specification for Carbon Steel Bolts, Studs, and Threaded Rod 60 000 PSI Tensile Strength.
- .9 ASTM A449-14(2020): Standard Specification for Hex Cap Screws, Bolts and Studs, Steel, Heat Treated, 120/105/90 ksi Minimum Tensile Strength, General Use.
- .10 ASTM A492-95(2019): Standard Specification for Stainless Steel Rope Wire.
- .11 ASTM A563/A563M-21a: Standard Specification for Carbon and Alloy Steel Nuts (Inch and Metric).
- .12 ASTM A603-19: Standard Specification for Metallic-Coated Steel Structural Wire Rope.
- .13 ASTM A653/A653M-20: Standard Specification for Steel Sheet, Zinc-Coated (Galvanized) or Zinc-Iron Alloy-Coated (Galvannealed) by the Hot-Dip Process.
- .14 ASTM A780/A780M-09(2015): Standard Practice for Repair of Damaged and Uncoated Areas of Hot-Dip Galvanized Coatings.
- .15 ASTM A1008/A1008M-21: Standard Specification for Steel, Sheet, Cold-Rolled, Carbon, Structural, High-Strength Low-Alloy, High-Strength Low-Alloy with Improved Formability, Required Hardness, Solution Hardened, and Bake Hardenable.

- .16 ASTM B36/B36M-18: Standard Specification for Brass Plate, Sheet, Strip, and Rolled Bar.
  - .17 ASTM B103/B103M-19: Standard Specification for Phosphor Bronze Plate, Sheet, Strip, and Rolled Bar.
  - .18 ASTM B139/B139M-12: Standard Specification for Phosphor Bronze Rod, Bar and Shapes.
  - .19 ASTM B209/B209M-21: Standard Specification for Aluminum and Aluminum-Alloy Sheet and Plate.
  - .20 ASTM B221M-21: Standard Specification for Aluminum and Aluminum-Alloy Extruded Bars, Rods, Wire, Profiles, and Tubes (Metric).
  - .21 ASTM F436/F436M-19: Standard Specification for Hardened Steel Washers Inch and Metric Dimensions.
  - .22 ASTM F467M-06a(2012): Standard Specification for Nonferrous Nuts for General Use (Metric).
  - .23 ASTM F468M-06(2012): Standard Specification for Nonferrous Bolts, Hex Cap Screws, and Studs for General Use (Metric).
  - .24 ASTM F593-17: Standard Specification for Stainless Steel Bolts, Hex Cap Screws and Studs.
  - .25 ASTM F594-09(2020): Standard Specification for Stainless Steel Nuts.
  - .26 ASTM F1267-18: Standard Specification for Metal, Expanded, Steel.
  - .27 ASTM F3125/F3125M-19e2: Standard Specification for High Strength Structural Bolts and Assemblies, Steel and Alloy Steel, Heat Treated, Inch Dimensions 120 ksi and 150 ksi Minimum Tensile Strength, and Metric Dimensions 830 MPa and 1040 MPa Minimum Tensile Strength.
  - .28 CSA A500-16: Building Guards.
  - .29 CSA G40.20-13 (R2018): General Requirements for Rolled or Welded Structural Quality Steel.
  - .30 CSA G40.21-13 (R2018): Structural Quality Steel.
  - .31 CSA S136-16: North American Specification for the Design of Cold-Formed Steel Structural Members.
  - .32 CSA W47.1:19: Certification of Companies for Fusion Welding of Steel.
  - .33 CSA W47.2-11 (R2020): Certification of Companies for Fusion Welding of Aluminum.
  - .34 CSA W55.3-08 (R2018): Certification of Companies for Resistance Welding of Steel and Aluminum.
  - .35 CSA W59-18: Welded Steel Construction.
  - .36 CSA W59.2-M1991 (R2018): Welded Aluminum Construction.
- 1.3 SHOP DRAWINGS
- .1 Submit Shop Drawings as specified in Section 01 33 00.
  - .2 Shop Drawings: Project-specific drawings, prepared for each required custom-fabricated metal item, illustrating profiles, sizes, connection attachments, reinforcing, anchorage, size and type of fasteners, and accessories.

- .3 The work described in this Section consists of the supply and installation for miscellaneous metals, fabrication, assembling erection prime, finish and touch-up painting including the following items:

Counter brackets.  
Steel angle lintels.  
Steel post framing supports as indicated.  
Miscellaneous bulkhead support details.  
Steel stair and steel guard.  
and as indicated on drawings

#### 1.4 QUALIFICATIONS

- .1 Retain a Professional Engineer, licensed in the Province of Ontario, with experience in Work of comparable complexity and scope, to perform the following services as part of the Work of this Section:
- Design steel stairs, handrails and railings and metal fabrication items that are required to resist live, dead, lateral, wind, or seismic loads.
  - Review, stamp, date, and sign shop drawings.
- .2 Fabricator: A firm specializing in fabricating custom metal components, and having minimum 3 years documented experience. Welders: Workers certified by CWB to CSA W47.1, CSA W47.2 and CSA W55.3 as applicable.
- .3 Workmanship: Fabricate Work of this Section to meet the required class of workmanship indicated below in accordance with AMP 555, Section 8.
- .1 Class 1: for use on direct exposed to view fabricated items:
- .1 Exposed surfaces are finished smooth with pitts, mill marks, nicks, burrs, sharp edges, and scratches filled or ground off. Defects should not show when painted, polished, or finished.
- .2 Welds should be concealed where possible. Exposed welds are ground to small radius with uniform sized cove unless otherwise noted.
- .3 Distortions should not be visible to the eye.
- .4 Exposed joints are fitted to a hairline finish.

## 2 Products

### 2.1 DESIGN CRITERIA

- .1 Refer to Drawings for details of metal fabrication work and related items not specifically listed in this Section.
- .2 Where work is required to be built into work of other Sections supply such members to respective Sections.  
Provide metal fabrication items indicated below and items not indicated to be supplied under other Sections. The following items includes miscellaneous and metal fabrication including but not limited to the items listed below.
- .3 Design cold-formed steel fabrications to CSA S136.

### 2.2 MATERIALS

- .1 Galvanized Sheet Steel: To ASTM A653/A653M, Structural Steel (SS) Grade 230, Types 1 and 2; cold-rolled sheet steel, galvanized; thicknesses as indicated.
- .2 Sheet Steel: To ASTM A1008/A1008M, Structural Steel (SS) Grade 230, Types 1 and 2;

cold-rolled sheet steel, thicknesses as indicated.

- .3 Steel Sections and Plates: To CSA G40.20 and CSA G40.21, Grade 300W; profiles and sizes as indicated.
- .4 Hollow Structural Steel Sections: To CSA G40.20 and CSA G40.21, Grade 350W, Class H; sizes as indicated.
- .5 Stainless Steel Sheet, Sections and Plates: To ASTM A240/A240M, Type 304L for welded applications and Type 304 for other applications; thicknesses and sizes as indicated.
- .6 Stainless Steel Tubing: To ASTM A269/A269M, Grade TP316L; thicknesses, diameters and sizes as indicated.
- .7 Stainless Steel Bars and Shapes: To ASTM A276/A276M, Type 304L for welded applications and Type 304 for other applications; sizes and profiles as indicated.
- .8 Stainless Steel Rope Wire: To ASTM A492, Type 316.
- .9 Extruded Aluminum: To ASTM B221M, 6063 alloy, T6 temper; profiles and sizes as indicated.
- .10 Aluminum Sheet: To ASTM B209/B209M, 3003-H14 alloy for shop-painted material and 5005-H32 alloy for anodized material; thicknesses as indicated.
- .11 Brass: To ASTM B36/B36M, UNS C22000 alloy, hot rolled temper; profiles and sizes as indicated.
- .12 Bronze Plate, Strip and Sheet: To ASTM B103/B103M, UNS C53400; leaded phosphor type, profiles and sizes as indicated.
- .13 Cast Bronze: To ASTM B139/B139M; phosphor type, profiles and sizes as indicated.

## 2.3 ACCESSORIES

- .1 Stainless Steel Bolts: To ASTM F593, Group 1.
- .2 Stainless Steel Nuts and Washers: To ASTM F594, Group 1.
- .3 High-Strength Bolts: To ASTM F3125/F3125M, Type 1 for interior applications, Type 3 for exterior applications; quenched and tempered steel heavy hex structural bolts.
- .4 Medium-Strength Bolts: To ASTM A449, Type 1 for interior applications, Type 3 for exterior applications; quenched and tempered steel hex bolts.
- .5 Machine Bolts: To ASTM A307, Grade A; carbon and alloy steel, galvanized where noted.
- .6 Steel Nuts: To ASTM A563/A563M, Grade A, Heavy Hex Style for use with high strength bolts, and Hex Style for use with medium strength bolts and machine bolts; carbon and alloy steel; galvanized where noted.
- .7 Steel Washers: To ASTM F436/F436M, Type 1 for interior applications, Type 3 for exterior applications; hardened steel washers, circular, bevelled and clipped types as required.
- .8 Aluminum Bolts: To ASTM F468M, shop finished to match adjacent surfaces.
- .9 Aluminum Nuts and Washers: To ASTM F467M, including plain washers; shop finished to match adjacent surfaces.
- .10 Wire Rope Clips: To Fed. Spec. FF-C-450, Type 1, Class 1.
- .11 Wire Rope Hardware Fittings: Stainless steel clevis ends and threaded bolt ends, sizes necessary to accommodate stainless steel wire rope diameter, and as required to accommodate design loads; by Jakob Rope Systems.
- .12 Welding Materials: To CSA W59 and CSA W59.2.

## 2.4 PRIMERS

- .1 Primer for Ferrous Metal Surfaces: Red oxide type.
- .2 Primer for Galvanized Surfaces: Zinc-rich paint type.

## 2.5 FABRICATION

- .1 Prior to fabrication, verify existing conditions and take field measurements to ensure perfect fit of fabricated items.
- .2 Fabricate cold-formed steel components to CSA S136.
- .3 Fabricate metal guards, including balustrades, railings, and handrails to CSA A500.
- .4 Shop weld steel components to CSA W59.
- .5 Shop weld aluminum components to CSA W59.2.
- .6 Fit and shop assemble components in largest practical sections to accommodate delivery to Place of the Work.
- .7 Seal joints with continuous welds.
- .8 Grind visually-exposed joints flush and smooth with adjacent finish surface.
- .9 Make visually-exposed joints butt tight, flush and hairline.
- .10 Exposed Mechanical Fastenings: Flush countersunk screws or bolts; except where specifically noted otherwise.
- .11 Supply components required for anchorage of fabrications.

## 2.6 FINISHES

- .1 Shop Priming:
  - .1 Clean surfaces of rust, scale, grease, and foreign matter prior to shop priming.
  - .2 Do not prime surfaces designated to come into direct contact with concrete, or where field welding is required.
  - .3 Prime components using minimum two coats primer.
- .2 Galvanized Coating on Steel Components: To ASTM A123/A123M, Z275 hot dipped zinc alloy coating.
- .3 Galvanized Coating on Steel Hardware: To ASTM A153/A153M, Class B2 hot dipped zinc alloy coating.
- .4 Galvanized Coating on Sheet Steel: To ASTM A653/A653M, Z275 hot dipped zinc alloy coating.
- .5 Stainless Steel: To AISI No. 4 - Brushed.
- .6 Brass: To AISI No. 4 - Brushed.
- .7 Anodized Coating on Aluminum: To AAMA 611, AA-M12C22A31, Class II Clear Anodic Oxide treatment, No. 17.
- .8 Monochromatic Paint Coating on Aluminum: To AAMA 2605; two-coat thermosetting fluoropolymer PVDF liquid extrusion and coil coating, factory-applied to 0.03 mm dry film thickness; eg. Duranar by PPG Industries, Inc.; colours as selected by Consultant.
- .9 Metallic Paint Coating on Aluminum: To AAMA 2605; three-coat thermosetting fluoropolymer PVDF liquid extrusion and coil coating, complete with metal flakes incorporated in colour coat; factory-applied to 0.04 mm dry film thickness; eg. Duranar XL by PPG Industries, Inc.; colour as selected by Consultant.
- .10 Powder Coated Finish on Metal Components: To AAMA 2605; electrostatically sprayed

polymer powder, factory-applied to 0.05 mm dry film thickness; colours as selected by Consultant.

- .11 Monochromatic Paint Coating on Sheet Steel: Two-coat silicone modified polyester coil coating, factory-applied to 0.028 mm dry film thickness; eg. WeatherXL by Valspar, colours as selected by Consultant.

### 3 Execution

#### 3.1 PREPARATION

- .1 Make provision for erection loads with temporary bracing.
- .2 Clean and strip primed steel items to bare metal where site welding is required.
- .3 Supply items required to be cast into concrete and or embedded in masonry with setting templates, to appropriate Sections.

#### 3.2 INSTALLATION

- .1 Install components plumb and level, accurately fitted, free from distortion or defects.
- .2 Provide fasteners and anchors necessary to secure components rigidly in place.
- .3 Field weld steel components to CSA W59.
- .4 Field weld aluminum components to CSA W59.2.
- .5 Field bolt and weld to match shop bolting and welding.
- .6 Mechanically fasten joints butted tight, flush, and hairline.
- .7 Grind welds smooth and flush.
- .8 After erection, prime welds, abrasions, and surfaces not yet shop primed or galvanized, except surfaces to be in direct contact with concrete.
- .9 Make Good damaged galvanized coatings to ASTM A780/A780M.

#### 3.3 SCHEDULE

- .1 The following schedule is a list of principal items only. Refer to Drawings for items not specifically scheduled.
  - .1 Sleeves and Openings: Including templates and required information, supplied to appropriate Sections.
  - .2 Steel angle or channel framing supports as indicated, Miscellaneous bulkhead support details and as indicated on drawings
  - .3 Attachments: Anchor bolts, washers, nuts, lag screws, expansion shields, toggles, straps, sleeves, brackets, etc. as required and secured with sufficient self-tapping shake-proof screws with flat countersunk heads.
  - .4 Brackets: Fabricated from mild steel plate, sizes and configurations as required to support countertops, shelving, seating, benches, valances, coat hooks, and other similar components; pre-drilled for fastening of other components.
  - .5 Lateral Support Brackets for Masonry Partitions: 75 x 75 mm steel angles, 6 mm thick, as follows:
    - .1 Concealed Conditions: 200 mm long and spaced at 3 000 mm OC; minimum two anchors each.
    - .2 Exposed Conditions: Continuous lengths, anchored at 1 000 mm OC.
  - .6 And as indicated in the drawings.

END OF SECTION



1 General

1.1 RELATED SECTIONS

- .1 Section 06 20 00 - Finish Carpentry.
- .2 Section 06 40 00 - Architectural Woodwork.
- .3 Section 07 62 00 - Sheet Metal Flashing and Trim.

1.2 REFERENCES

- .1 ASTM A153/A153M-16a: Standard Specification for Zinc Coating (Hot-Dip) on Iron and Steel Hardware.
- .2 ASTM F593-17: Standard Specification for Stainless Steel Bolts, Hex Cap Screws and Studs.
- .3 ASTM F594-09(2020): Standard Specification for Stainless Steel Nuts.
- .4 ASTM F1667-21: Standard Specification for Driven Fasteners: Nails, Spikes and Staples.
- .5 CAN/CSA O80 Series-08 (R2012) Consolidated: Wood Preservation.
- .6 CAN/CSA-O86-09 Consolidated: Engineering Design in Wood.
- .7 CSA O112.9-10: Evaluation of Adhesives for Structural Wood Products (Exterior Exposure).
- .8 CSA O121-08 (R2013): Douglas Fir Plywood.
- .9 CSA O141-05 (R2009): Softwood Lumber.
- .10 CSA O151-09: Canadian Softwood Plywood.
- .11 NLGA Standard Grading Rules for Canadian Lumber, August 2017 Edition.
- .12 CAN/ULC-S102-2018 (REV1): Standard Method of Test for Surface Burning Characteristics of Building Materials and Assemblies.

1.3 QUALITY ASSURANCE

- .1 Lumber Identification: Grade stamp clearly identifying assigned grade, mill of origin, moisture content at time of manufacture, species or species group, and grading authority having jurisdiction over mill of origin.
- .2 Plywood Identification: Face or edge stamp depending on appearance requirement, clearly identifying panel grade, species designation, mill identification, certifying agency, and waterproof glue bond designation.

1.4 DELIVERY, STORAGE AND HANDLING

- .1 Refer to Section 01 60 00.
- .2 Deliver and store Products under waterproof cover.
- .3 Prevent damage to Products, existing property and to the Work.
- .4 Store Products where it does not hinder progress of the Work.

2 Products

2.1 MATERIALS

- .1 Dimension Lumber: To CSA O141, S4S; SPF species, kiln dried to S-DRY moisture content; preservative treated for exterior applications where noted on Drawings, sizes as indicated on Drawings; NLGA Light Framing Grade Category, Standard and Better Common Grade Mix.
- .2 Plywood - Exterior Applications: To CSA O121, DFP species, SHG Grade; veneer core, butt edge, unsanded faces; preservative treated, thicknesses as indicated on Drawings.
- .3 Plywood - Interior Applications: To CSA O151, CSP species, SHG Grade; veneer core, butt edge, unsanded faces; flame retardant treated where noted, thicknesses as indicated on Drawings.

2.2 ACCESSORIES

- .1 Nails: To ASTM F1667, Type I (NL); common wire type for general use and spiral type for structural connections; sizes necessary to ensure adequate securement; and as follows:
  - .1 For Use with Preservative Treated Wood: Type 304 or 316 stainless steel.
  - .2 For Use with Untreated Wood: Galvanized steel.
- .2 Spikes: To ASTM F1667, Type III (SP); common wire type for general use and spiral type for structural connections; sizes necessary to ensure adequate securement; and as follows:
  - .1 For Use with Preservative Treated Wood: Type 304 or 316 stainless steel.
  - .2 For Use with Untreated Wood: Galvanized steel.
- .3 Staples: To ASTM F1667, Type IV (ST); common wire; leg length necessary to ensure adequate securement; and as follows:
  - .1 For Use with Preservative Treated Wood: Type 304 or 316 stainless steel.
  - .2 For Use with Untreated Wood: Galvanized steel.
- .4 Screws: Bugle head, power driven type, sizes necessary to ensure adequate securement; types as follows:
  - .1 For Use with Preservative Treated Wood: Type 304 or 316 stainless steel.
  - .2 For Use with Untreated Wood: Galvanized steel.
- .5 Stainless Steel Bolts: To ASTM F593, Group 1.
- .6 Stainless Steel Nuts: To ASTM F594, Group 1.
- .7 Adhesive: To CSA O112.9.
- .8 Anchors: Toggle bolt type for anchorage to hollow masonry, expansion shield and lag bolt type for anchorage to solid masonry or concrete, or bolts or ballistic fasteners for anchorages to steel.
- .9 Touch-Up Wood Preservative: To CAN/CSA O80; brush-applied copper azole (CBA-A or CA-B) or alkaline copper quaternary (ACQ) preservative.
- .10 Touch-up Flame Retardant Coating: To CAN/CSA O80; brush-applied Dricon by Lonza.

2.3 FINISHES

- .1 Flame Retardant Treatment
  - .1 Flame Retardant Treatment: To CAN/CSA O80; chemically treated and pressure impregnated; as follows:
    - .1 Surface Burning Characteristics (CAN/ULC-S102): Flame Spread Index  $\leq 25$ .
    - .2 Manufacturer and Product Name: eg. Dricon by Lonza.
  - .2 Flame retardant treated materials must bear a ULC classification label.

- .2 Wood Preservative Treatment:
    - .1 Wood Preservative Treatment: To CAN/CSA O80; chemically treated and pressure impregnated using copper azole (CBA-A or CA-B) or alkaline copper quaternary (ACQ) preservative.
    - .2 Preservative treated materials must bear CSA classification label.
    - .3 Make preservative treated materials available for inspection by Consultant at place of treatment, before shipment to Place of the Work.
  - .3 Galvanized Coating on Steel Hardware: To ASTM A153/A153M; 610 g/m<sup>2</sup> hot dipped zinc alloy coating.
- 3 Execution
- 3.1 SITE APPLIED WOOD TREATMENT
- .1 When wood in contact with exterior cementitious materials, roofing and related metal flashings has not been previously preservative treated, brush apply two coats of touch-up wood preservative, to CAN/CSA O80.
  - .2 Apply two coats of touch-up wood preservative to sawn ends of preservative treated material, to CAN/CSA O80.
  - .3 Apply two coats of touch-up flame retardant coating to sawn ends of flame retardant treated material, to CAN/CSA O80.
- 3.2 INSTALLATION
- .1 Erect wood framing members level and plumb.
  - .2 Place horizontal members laid flat, crown side up.
  - .3 Construct framing members full length without splices.
  - .4 Secure plywood sheets perpendicular to framing members, with ends staggered and sheet edges secured directly over firm bearing.
  - .5 Provide wood blocking required for attachment of fitments and equipment by other Sections.
  - .6 Provide 19 mm thick flame retardant treated plywood backer board on flame retardant treated wood blocking for mounting electrical equipment where indicated on Drawings.
  - .7 Construct curb and cant members of single pieces per location.
  - .8 Curb roof openings except where prefabricated curbs are provided.
  - .9 Form corners by lapping side members alternately.
  - .10 Coordinate work with installation of decking and support of decking at openings.

END OF SECTION

1 General

1.1 RELATED SECTIONS

- .1 Section 05 40 00 - Cold-Formed Metal Framing.
- .2 Section 06 16 63 - Cementitious Sheathing.
- .3 Section 07 21 00 - Thermal Insulation.
- .4 Section 07 21 19.13 - Foamed-in-Place Urethane Insulation.
- .5 Section 07 27 00 - Air Barriers.
- .6 Section 07 92 00 - Joint Sealants.

1.2 REFERENCES

- .1 ASTM C475/C475M-17: Standard Specification for Joint Compound and Joint Tape for Finishing Gypsum Board.
- .2 ASTM C954-18: Standard Specification for Steel Drill Screws for the Application of Gypsum Panel Products or Metal Plaster Bases to Steel Studs From 0.033 in. (0.84 mm) to 0.112 in. (2.84 mm) in Thickness.
- .3 ASTM C1002-20: Standard Specification for Steel Self-Piercing Tapping Screws for Application of Gypsum Panel Products or Metal Plaster Bases to Wood Studs or Steel Studs.
- .4 ASTM C1177/C1177M-17: Standard Specification for Glass Mat Gypsum Substrate for Use as Sheathing.
- .5 ASTM C1264-19: Standard Specification for Sampling, Inspection, Rejection, Certification, Packaging, Marking, Shipping, Handling, and Storage of Gypsum Panel Products.
- .6 ASTM C1280-18: Standard Specification for Application of Exterior Gypsum Panel Products for Use as Sheathing.
- .7 CGC Gypsum Construction Handbook.
- .8 CAN/CGSB-71.25-M88: Adhesive, for Bonding Drywall to Wood Framing and Metal Studs.
- .9 GA-214-2015: Recommended Levels of Finish for Gypsum Board, Glass Mat and Fiber-Reinforced Gypsum Panels.
- .10 CAN/ULC-S102-2018 (REV1): Standard Method of Test for Surface Burning Characteristics of Building Materials and Assemblies.
- .11 ULC List of Equipment and Materials.

1.3 QUALIFICATIONS

- .1 Applicators: A firm specializing in applying gypsum sheathing, and having minimum 5 years documented experience.

1.4 DELIVERY, STORAGE AND HANDLING

- .1 Conform to ASTM C1264.

## 2 Products

### 2.1 MANUFACTURERS

- .1 Manufacturers having Product considered acceptable for use:
  - .1 CertainTeed Canada, Inc.
  - .2 CGC Inc.
  - .3 G-P Gypsum Corporation.
- .2 Substitution Procedures: Refer to Section 01 25 00.

### 2.2 MATERIALS

- .1 Gypsum Sheathing Board (GSB-1): To ASTM C1177/C1177M; as follows:
  - .1 Thickness 12.7 mm.
  - .2 Edges: Square.
  - .3 Core: Silicone-treated gypsum.
  - .4 Facers: Glass fiber mesh, both sides.
  - .5 Manufacturer and Product Name: e.g., DensGlass Exterior Sheathing by G-P Gypsum Corporation.
- .2 Gypsum Sheathing Board (GSB-2): To ASTM C1177/C1177M, Abuse Resistant; as follows:
  - .1 Thickness: 15.9 mm.
  - .2 Edges: Square.
  - .3 Core: Dense gypsum core(non-combustible) with high strength glass fibre reinforcement.
  - .4 Facers: Glass fiber mesh facers, both sides.
  - .5 Flame Spread Index (CAN/ULC-S102):  $\leq 10$ .
  - .6 Manufacturer and Product Name: e.g., **DensArmor Plus® Abuse-Resistant Interior Panel** by G-P Gypsum Corporation.
- .3 Gypsum Board - Ceiling Board (GB-CLG): To ASTM C1396/C1396M;
  - .1 Thickness: 12.7 mm thick; gypsum panel with water- and mould-resistant, paper- facers, eased edges; maximum 6.5 kg/m<sup>2</sup> weight;
  - .2 Manufacturer and Product Name: e.g., Sheetrock Brand Ultralight Interior Ceiling Board Sag-Resistant by CGC Inc.
- .3 Steel Drill Screws: To ASTM C954; galvanized steel, sheet metal type.
- .4 Self-Tapping Screws: To ASTM C1002, Type S, Fine Thread; galvanized steel.
- .5 Adhesive: To CAN/CGSB-71.25-M.
- .6 Joint Materials: To ASTM C475/C475M; reinforcing tape, joint compound, adhesive, water, fasteners.
- .7 Joint Sealant: Exterior weatherseal sealant, Type SEAL-EXT as specified in Section 07 92 00.

3 Execution

3.1 INSTALLATION

- .1 Install Products to ASTM C1280.
- .2 NOTE: Installation of Impact Resistant Gypsum Board requires steel studs complying with ASTM C645 and shall be not less than 33 mils (0.836 mm) design thickness and shall be in accordance with CSA-S136 and ASTM C645.
- .3 Install boards perpendicular to supports with ends staggered.
- .4 Secure board edges over firm bearing.
- .5 Screw fasten boards to furring or framing.
- .6 Finish boards to GA-214, Level 1.
- .7 Finished work shall be plane and free from depressions.

END OF SECTION

1 General

1.1 RELATED SECTIONS

- .1 Section 06 10 00 - Rough Carpentry.
- .2 Section 06 24 00 - High Pressure Decorative Laminate.
- .3 Section 06 40 00 - Architectural Woodwork.
- .4 Section 07 92 00 - Joint Sealants.
- .5 Section 08 14 00 - Wood Doors.
- .6 Section 08 71 00 - Door Hardware.
- .7 Section 09 90 00 - Painting and Coating.

1.2 REFERENCES

- .1 ANSI A135.4-2004: Basic Hardboard.
- .2 ANSI A208.1-2009: Particleboard.
- .3 ANSI A208.2-2009: Medium Density Fiberboard (MDF) for Interior Applications.
- .4 ASTM B456-11e1: Standard Specification for Electrodeposited Coatings of Copper Plus Nickel Plus Chromium and Nickel Plus Chromium.
- .5 ASTM F1667-21: Standard Specification for Driven Fasteners: Nails, Spikes and Staples.
- .6 AWMAC NAAWS 4.0-2021: North American Architectural Woodwork Standards.
- .7 CHPVA Official Grading Rules for Canadian Hardwood Plywood.
- .8 CSA O121-08 (R2013): Douglas Fir Plywood.
- .9 CSA O141-05 (R2009): Softwood Lumber.
- .10 CSA O151-09: Canadian Softwood Plywood.
- .11 ANSI/HPVA HP-1-2020: American National Standard for Hardwood and Decorative Plywood.
- .12 NHLA Grading Rules.

1.3 SAMPLES

- .1 Submit samples as specified in Section 01 33 00.
- .2 Verification Samples: Duplicate samples, as follows:
  - .1 Melamine Composite Panel: 300 x 300 mm size, illustrating laminate-clad face colour, pattern, and texture; core materials; and quality of PVC edge banding.
  - .2 Hardwood Plywood: 300 x 300 mm size, illustrating full panel sheet, edge, and joint trim.
  - .3 MDF Trim: 300 mm long, illustrating size and shape of profiles.
  - .4 Hardwood Trim: 300 mm long, illustrating size and shape of profiles, and quality of wood grain.

1.4 QUALIFICATIONS

- .1 Trim and Finish Carpenter: A firm employing workers specializing in finish carpentry work, and having minimum 3 years documented experience.

2 Products

2.1 MATERIALS

- .1 Dressed Lumber - Softwood (DL-SWD): To CSA O141; SPF species, kiln dried to maximum 7 percent moisture content, with mixed grain capable of receiving a high-quality opaque finish; sizes as indicated on Drawings.
- .2 Dressed Lumber - Hardwood (DL-HWD): Maple species, to NHLA Select and Better Grade; kiln dried to maximum 7 percent moisture content, with vertical grain capable of receiving a high-quality transparent finish; sizes as indicated on Drawings.
- .3 Plywood - Softwood (PLY-SWD): CSP to CSA O151; SEL TF Grade; SPF veneer core of minimum 9 plies; thicknesses as indicated on Drawings; capable of receiving a high-quality opaque finish.
- .4 Plywood - Softwood, Moisture-Resistant Core (PLY-SWD-MR): CSP to CSA O151; SEL TF Grade; composite core of moisture-resistant particle board to ANSI A208.1, Grade M-3 - Exterior Glue; thicknesses as indicated on Drawings; capable of receiving a high-quality opaque finish.
- .5 Plywood - Hardwood (PLY-HWD): To ANSI/HPVA HP-1, Architectural G1S, thicknesses as indicated on Drawings; as follows:
  - .1 Core: Hardwood veneer core, minimum 9 plies.
  - .2 Face Veneers: Maple species; Face Grade A; Plain-Sliced; of clear Pleasing match grain capable of receiving a high-quality transparent finish.
- .6 Plywood - Hardwood, Moisture-Resistant Core (PLY-HWD-MR): To ANSI/HPVA HP-1, Architectural G1S, thicknesses as indicated on Drawings; as follows:
  - .1 Core: Composite core, moisture-resistant particle board to ANSI A208.1, Grade M-3 - Exterior Glue.
  - .2 Face Veneers: Maple species; Face Grade A; Plain-Sliced; of clear Pleasing match grain capable of receiving a high-quality transparent finish.
- .7 Particleboard (PB): To ANSI A208.1, Grade M-2; made from 100 percent post-industrial wood fibres; minimum 635 kg/m<sup>3</sup> density and maximum 6 percent moisture content; no added urea formaldehyde (nauf); certified EPP by Composite Panel Association; thicknesses as indicated on Drawings.
- .8 Melamine Composite Panel (MCP): Particleboard core with factory-applied low-pressure laminate (LPL) thermo-fused to both faces; Premium quality; thicknesses as indicated on Drawings; colours, textures and patterns as selected by Consultant.
- .9 Medium Density Fiberboard (MDF): To ANSI A208.2, Grade MD; having minimum 740 kg/m<sup>3</sup> density and maximum moisture content between 4.5 - 8.0 percent; thicknesses as indicated on Drawings.
- .10 Hardboard (HB): To ANSI A135.4, Class 1 - Tempered; inter-felted ligno-cellulosic fibers consolidated under heat and pressure; minimum 500 kg/m<sup>3</sup> density; S1S surface finish; thicknesses as indicated on Drawings.



## 2.2 ACCESSORIES

- .1 Decorative Laminate: High pressure decorative laminate, Type HPDL as specified in Section 06 24 00.
- .2 Contact Adhesives: Water base type.
- .3 Wall Adhesive: Solvent release, cartridge type, compatible with wall substrate, capable of achieving durable bond.
- .4 Nails: To ASTM F1667, Type I (NL), galvanized steel, common wire; sizes necessary to ensure adequate securement.
- .5 Staples: To ASTM F1667, Type IV (ST); galvanized steel, common wire; leg length necessary to ensure adequate securement.
- .6 Screws: Galvanized steel, tapered head suitable for counter sunk applications; sizes necessary to ensure adequate securement.
- .7 Bolts, Nuts, Washers, Lags and Blind Fasteners: Size and type to suit application; plain finish.
- .8 Dimension Lumber: As specified in Section 06 10 00.
- .9 Primer: Alkyd primer sealer type.
- .10 Wood Filler: Solvent base, tinted to match surface finish colour.
- .11 Joint Sealant: Interior general-purpose sealant, Type SEAL-INT-GP as specified in Section 07 92 00.

## 2.3 FINISHES

- .1 Chrome/Nickel Plating on Metal Components: To ASTM B456, Type SC 2; electrodeposited nickel plus chromium coating; Polished.

## 3 Execution

### 3.1 INSTALLATION

- .1 Install Products to AWMAC NAAWS 4.0, Custom Grade.
- .2 Set and secure Products in place; straight, plumb and level.
- .3 Unless noted otherwise, install Products with nails, screws, or bolts with blind fasteners spaced at 400 mm OC, or adhesive as required by specific installation requirements.
- .4 Finish exposed edges of veneer-clad panels with 3.2 mm thick hardwood edge trim, glued and nailed.
- .5 Finish exposed edges of laminate-clad panels with 1.0 mm thick decorative laminate edge banding, applied using hot melt adhesive.
- .6 Apply decorative laminate to core materials as specified in Section 06 24 00.
- .7 Install MCP shelf and metal tube closet rod where indicated on Drawings.
- .8 Install coat hooks where indicated on Drawings.
- .9 Install wood doors as specified in Section 08 14 00.
- .10 Install door hardware as specified in Section 08 71 00.

.11 Seal gaps and joints as specified in Section 07 92 00.

3.2 ADJUSTING AND CLEANING

.1 Set exposed fasteners.

.2 Apply wood filler over exposed nail and staple indentations. Allow to dry and sand smooth.

.3 Conceal countersunk fasteners with matching hardwood dowels, sanded smooth and flush to adjacent surface.

.4 Clean and prepare surfaces for site finishing. Coordinate with Section 09 90 00.

3.3 EXTENDED WARRANTY

.1 Submit a extended warranty for plastic laminate work of this Section in accordance with General Conditions, except that warranty period is extended to 2 years from date of Substantial Performance of the Work.

.2 Warrant against defects in material and workmanship including but not limited to opening of joints, cracking, shrinkage, warpage, and delamination of plastic laminate.

.3 Coverage: Complete replacement including affected adjacent Work.

END OF SECTION

1 General

1.1 RELATED SECTIONS

- .1 Section 03 30 00 - Cast-in-Place Concrete.
- .2 Section 03 40 00 - Precast Concrete Slabs.
- .3 Section 04 22 00 - Concrete Unit Masonry.
- .4 Section 05 50 00 - Metal Fabrications.
- .5 Section 07 81 00 - Applied Fireproofing.
- .6 Section 07 92 00 - Joint Sealants.
- .7 Section 08 44 13 - Glazed Aluminum Curtain Wall.
- .8 Section 09 21 16 - Gypsum Board Assemblies.

1.2 REFERENCES

- .1 ASTM C303-21: Standard Test Method for Dimensions and Density of Preformed Block and Board-Type Thermal Insulation.
- .2 ASTM C1104/C1104M-19: Standard Test Method for Determining the Water Vapor Sorption of Unfaced Mineral Fiber Insulation.
- .3 ASTM E84-21a: Standard Test Method for Surface Burning Characteristics of Building Materials.
- .4 ASTM E119-20: Standard Test Methods for Fire Tests of Building Construction and Materials.
- .5 ASTM E814-13a(2017): Standard Test Method for Fire Tests of Penetration Fire Stop Systems.
- .6 ASTM E2174-20a: Standard Practice for On-Site Inspection of Installed Firestop Systems.
- .7 ASTM E2393-20a: Standard Practice for On-Site Inspection of Installed Fire Resistive Joint Systems and Perimeter Fire Barriers.
- .8 CAN/ULC-S101-14 (REV1): Standard Method of Fire Endurance Tests of Building Construction and Materials.
- .9 CAN/ULC-S102-2018 (REV1): Standard Method of Test for Surface Burning Characteristics of Building Materials and Assemblies.
- .10 CAN/ULC-S114-2018: Standard Method of Test for Determination of Non-Combustibility in Building Materials.
- .11 CAN/ULC-S115-2018: Standard Method of Fire Tests of Firestop Systems.
- .12 CAN/ULC-S129-15 (REV1): Standard Method of Test for Smoulder Resistance of Insulation (Basket Method).
- .13 CAN/ULC-S702.1-14 (R2019): Standard for Mineral Fibre Thermal Insulation for Buildings, Part 1: Material Specification.
- .14 ULC List of Equipment and Materials.

### 1.3 PREINSTALLATION MEETINGS

- .1 Prior to commencement of firestopping, arrange and conduct a preinstallation meeting as specified in Section 01 31 00.
- .2 Preinstallation Meeting: Discuss proposed methods and materials to be used in instances.
- .3 Representatives of Owner, Consultant, Contractor, Subcontractor, manufacturer and authority having jurisdiction are to be in attendance.
- .4 Do not conduct meeting unless identified parties are present.

### 1.4 PRODUCT DATA

- .1 Submit Product data as specified in Section 01 33 00.
- .2 Product Data: Sealant manufacturer's standard installation instructions and standard drawings, indicating ULC or WHI test designations.

### 1.5 SHOP DRAWINGS

- .1 Submit Shop Drawings as specified in Section 01 33 00.
- .2 Shop Drawings: Project-specific drawings, illustrating sizes of openings, nature of penetrations, and tested method of firestop and smoke seal protection being proposed.
  - .1 Shop Drawings are to be sealed, signed and dated by manufacturer's design engineer.
  - .2 Submit Shop Drawings to Consultant and to authority having jurisdiction for review and acceptance.

### 1.6 CERTIFICATES

- .1 Submit certification as specified in Section 01 33 00.
- .2 Certificate: Sealant manufacturer's letter of certification verifying Products meet or exceed specified requirements.

### 1.7 TEST AND EVALUATION REPORTS

- .1 Submit test reports as specified in Section 01 33 00.
- .2 Test Reports: Manufacturer's standard test results indicating Products meet specified performance criteria, prepared by independent testing agency, and current within past two years.

### 1.8 FIELD QUALITY CONTROL SUBMITTALS

- .1 Submit manufacturer's field inspection reports as specified in Section 01 40 00.
- .2 Manufacturer's Field Inspection Reports: Manufacturer's written acceptance of installation based on regular inspections.

### 1.9 QUALIFICATIONS

- .1 Manufacturer's Design Engineer: A professional engineer having minimum 10 years documented experience designing firestop and smoke seal systems, and licensed to practice at Place of the Work.
- .2 Installer: A firm specializing in installing firestopping and smoke seal systems, and approved or certified as an installer by manufacturer.

#### 1.10 MOCK-UPS

- .1 Construct mock-ups as specified in Section 01 40 00.
- .2 Mock-ups: One example of each fire-resistant joint and penetration fire stop required on Project, including representative substrates and penetrating components, for each fire rating required at each type of wall, floor and roof construction.
- .3 Comply with project requirements as to thickness and density of application to achieve required fire rating.
- .4 Accepted mock-ups will be used as the standard for acceptance of the Work.
- .5 Remove and replace installed Product that does not conform to accepted mock-up.
- .6 Remove mock-ups from Place of the Work upon Ready-for-Takeover.

#### 1.11 DELIVERY, STORAGE AND HANDLING

- .1 Refer to Section 01 60 00.
- .2 Deliver Products to Place of the Work in original unopened packages.
- .3 Store Products in an enclosed shelter, preventing damage to containers.

#### 1.12 AMBIENT CONDITIONS

- .1 Do not apply sealants when temperature of substrate material and surrounding air is below 5 degrees C.
- .2 Maintain sealant at minimum 18 degrees C for best workability.

### 2 Products

#### 2.1 MANUFACTURERS

- .1 Manufacturers having Product considered acceptable for use:
  - .1 3M Company Canada.
  - .2 AD Fire Protection.
  - .3 Hilti Canada.
  - .4 Nuco Inc.
  - .5 Specified Technologies Inc.
  - .6 Tremco.
  - .7 EMASEAL
- .2 Substitution Procedures: Refer to Section 01 25 00.

#### 2.2 DESIGN AND PERFORMANCE CRITERIA

- .1 Seal empty holes and penetrations at floors, fire rated walls and smoke barrier walls.
- .2 Seal holes accommodating penetrating items such as cables, cable trays, pipes, ducts and conduits.
- .3 Design firestopping system to maintain integrity of time rated construction by providing a seal against spread of heat, flame and smoke.
- .4 Fire Rated seismic expansion joint. Fire-Rated, Watertight, Traffic Bearing, 100% Movement, Quiet, Non-Invasive Anchoring, UL/ULC 2079 Certified for Decks and Floors.
- .5 Systems shall be ULC or ULI classified or listed by WHI for appropriate required time rating.

- .6 Provide firestopping and smoke sealing systems to CAN/ULC-S115 and as described below:
  - .1 Asbestos free materials and systems fully capable of maintaining an effective barrier against gases, flame and smoke in compliance with CAN/ULC-S115, not exceeding opening sizes stated.
  - .2 Service Penetration Assemblies: Certified by CAN/ULC-S115 and used by ULC Guide 40 U19. Service components listed as certified in this guide are noted under Label Service of ULC.
- .7 Fire resistance rating of firestopping assembly must meet or exceed fire resistance rating of floor or wall being penetrated.
- .8 Provide elastomeric seal at openings around penetrations for pipes, ductwork and other mechanical items requiring sound and vibration control. Do not use cementitious or rigid seals at such locations.
- .9 Damming and back up materials, supports and anchoring devices shall be to manufacturer's recommendations, and in strict accordance with tested assembly being installed as acceptable to authorities having jurisdiction.
- .10 Firestopping compounds shall not contain volatile solvents or require special application to protect plastic pipe from firestopping compound.

### 2.3 MATERIALS

- .1 Primer: As recommended by sealant manufacturer for specific material, substrate and end use.
- .2 Firestop Accessories: Firestop foams, boards, blocks, collars, wraps, putty's and plugs; to CAN/ULC-S115; ULC labelled; types as listed in tested assemblies.
- .3 Firestop Insulation: To CAN/ULC-S702.1, Type 2; mineral fibre manufactured from rock or slag, suitable for manual application; and having the following physical properties when tested to the identified standard:
  - .1 Density (ASTM C303):  $\geq 72 \text{ kg/m}^3$ .
  - .2 Combustibility (CAN/ULC-S114): Noncombustible.
  - .3 Melt Temperature:  $> 1\ 175$  degrees C.
  - .4 Surface Burning Characteristics: To CAN/ULC-S102, as follows:
    - .1 Flame Spread Index  $\leq 0$ .
    - .2 Smoke Developed Index  $\leq 0$ .
  - .5 Moisture Sorption (ASTM C1104/C1104M): 0.04 percent.
  - .6 Smoulder Resistance (CAN/ULC-S129): 0.01 percent.
- .4 Firestop Sealants: To CAN/ULC-S115; ULC labelled; non-sagging type for vertical applications; types as listed in tested assemblies.
- .5 Fire Rated seismic expansion joint system. ie. SJS-FR1 (1-hour rated) from emseal

### 3 Execution

#### 3.1 EXAMINATION

- .1 Refer to Section 01 71 00.
- .2 Confirm compatibility of surfaces to receive sealant materials.
- .3 Verify surfaces of openings are sound, clean, dry and ready to receive application of sealant.

- .4 Verify penetrating elements are securely fixed and properly located.

### 3.2 PREPARATION

- .1 Protect adjacent surfaces and equipment from damage.
- .2 Clean contact surfaces of dirt, dust, grease, oil, loose material, or other matter which may affect bond of sealant.
- .3 Remove incompatible materials which affect bond by scraping, brushing, water or solvent cleaning, or sandblasting.

### 3.3 APPLICATION

- .1 Install firestop insulation in compacted thicknesses required by ULC design. Compress insulation approximately 33 percent.
- .2 Apply sealant in strict accordance with ULC certification.
- .3 Coordinate and cooperate with adjacent, contiguous and related Subcontractors to ensure a proper and timely installation.
- .4 Seal holes and voids made by penetrating items to ensure an effective fire and smoke barrier.
- .5 Seal intersections and penetrations of floors, ceilings, walls and columns.
- .6 Seal around cutouts for facility services.
- .7 Wrap non-insulated heated pipes that may be subject to movement with non-combustible smooth material to permit pipe to move without damaging firestopping and smoke seal.
- .8 Maintain integrity of insulation and vapour retarders on insulated pipes and ducts at fire separation.
- .9 Where floor openings exceed 100 mm in width and may be subjected to traffic or loading, install cover plate systems capable of supporting same loading as floor.

### 3.4 FIELD QUALITY CONTROL

- .1 Perform field testing and inspection as specified in Section 01 40 00.
- .2 Inspect penetration firestop systems to ASTM E2174.
- .3 Inspect fire-resistant joint systems to ASTM E2393.
- .4 Examine finished penetrations to ensure proper installation before concealing or enclosing any areas of work.
- .5 Keep areas of work accessible until inspection has been completed.
- .6 Manufacturer's Field Service: Inspect and confirm completed installation is in strict accordance with ULC requirements.
- .7 Correct defective work and re-inspect to verify compliance with requirements.

### 3.5 CLEANING

- .1 Refer to Section 01 74 00.

- .2 Immediately remove spots, smears, stains, residues, adhesives, and other disfigurements from installation, including from adjacent surfaces.
- .3 Do not use Products containing volatile solvents.
- .4 Leave the Work in a clean and satisfactory condition.

3.6 PROTECTION

- .1 Refer to Section 01 76 00.
- .2 Protect firestopping assemblies from damage until Ready-for-Takeover.
- .3 Make Good damaged firestopping assemblies.

END OF SECTION



1 General

1.1 RELATED SECTIONS

- .1 Section 03 30 00 - Cast-in-Place Concrete.
- .2 Section 04 05 23 - Masonry Accessories.
- .3 Section 06 20 00 - Finish Carpentry.
- .4 Section 06 40 00 - Architectural Woodwork.
- .5 Section 07 13 26 - Self-Adhering Sheet Waterproofing.
- .6 Section 07 26 00 - Vapour Retarders.
- .7 Section 07 27 00 - Air Barriers.
- .8 Section 07 27 36 - Sprayed Foam Air Barrier.
- .9 Section 07 42 13 - Metal Wall Panels.
- .10 Section 07 62 00 - Sheet Metal Flashing and Trim.
- .11 Section 07 84 00 - Firestopping.
- .12 Section 08 12 13 - Hollow Metal Frames.
- .13 Section 08 44 13 - Glazed Aluminum Curtain Wall.
- .14 Section 08 51 13 - Aluminum Windows.
- .15 Section 08 80 00 - Glazing.
- .16 Section 08 90 00 - Louvers and Vents.
- .17 Section 09 21 16 - Gypsum Board Assemblies.
- .18 Section 09 30 00 - Tiling.
- .19 Section 09 51 23 - Acoustical Tile Ceilings.
- .20 Section 22 44 13 - Plumbing Fixtures.

1.2 REFERENCES

- .1 ASTM C919-19: Standard Practice for Use of Sealants in Acoustical Applications.
- .2 ASTM C920-18: Standard Specification for Elastomeric Joint Sealants.
- .3 ASTM C1193-16: Standard Guide for Use of Joint Sealants.
- .4 ASTM C1481-12(2017): Standard Specification for Use of Joint Sealants with Exterior Insulation and Finish Systems (EIFS).
- .5 ASTM C1521-19(2020): Standard Practice for Evaluating Adhesion of Installed Weatherproofing Sealant Joints.
- .6 CAN/CGSB-19.13-M87: Sealing Compound, One Component, Elastomeric, Chemical Curing.
- .7 CAN/CGSB-19.17-M90: One Component Acrylic Emulsion Base Sealing Compound.

1.3 SAMPLES

- .1 Submit samples as specified in Section 01 33 00.

- .2 Selection Samples: Duplicate samples of each specified joint sealant, illustrating available colour selections.
- 1.4 MANUFACTURER REPORTS
  - .1 Submit manufacturers' reports as specified in Section 01 40 00.
  - .2 Manufacturers' Reports: Manufacturer field review reports, as specified below.
- 1.5 QUALIFICATIONS
  - .1 Applicators: Workers experienced with applying joint sealants, and having minimum 3 years documented experience.
- 1.6 DELIVERY, STORAGE AND HANDLING
  - .1 Refer to Section 01 60 00.
  - .2 Deliver Products in manufacturer's sealed packages.
  - .3 Store Products in warm, dry conditions.
- 1.7 AMBIENT CONDITIONS
  - .1 Do not install solvent curing sealants in enclosed building spaces.
  - .2 Maintain temperature and humidity recommended by the sealant manufacturer during and after installation.
- 1.8 WARRANTY
  - .1 Submit extended warranty in accordance with General Conditions of the Contract.
  - .2 Extended Warranty: For a period of 5 years, including coverage of installed sealants and accessories which fail to achieve air tight and watertight seal, exhibit loss of either adhesion or cohesion, or do not cure.
- 2 Products
  - 2.1 MANUFACTURERS
    - .1 Manufacturers of joint sealants having Product considered acceptable for use:
      - .1 Dow Chemical Company.
      - .2 General Electric.
      - .3 Master Builders Solutions Canada, Inc.
      - .4 Tremco.
    - .2 Manufacturers of flashing sealant having Product considered acceptable for use:
      - .1 Henry Company Canada.
      - .2 Tremco.
      - .3 W. R. Meadows of Canada Limited.
    - .3 Manufacturers of interior tiling sealants having Product considered acceptable for use:
      - .1 Mapei.
    - .4 Substitution Procedures: Refer to Section 01 25 00.
  - 2.2 PERFORMANCE CRITERIA
    - .1 Seal gaps between dissimilar Products, visible or otherwise.
    - .2 Protect building components from air infiltration and moisture penetration.

## 2.3 EXTERIOR SEALANTS

- .1 Weatherseal Sealant (SEAL-EXT): To ASTM C920, Type S, Grade NS, Class 35, Use NT, M, A and O; one-part, moisture curing, low modulus polyurethane sealant; accommodating joint movement of plus or minus 35 percent, with a 30- to 90-minute skin time; eg. Dymonic FC by Tremco, colours as selected by Consultant.
- .2 Weatherseal Sealant - High Movement (SEAL-EXT-HM): To ASTM C920, Type S, Grade NS, Class 50, Use NT, T, M, A, O, and I; one-part medium modulus, low VOC, UV stable, non-sag polyurethane sealant; accommodating joint movement of plus 100 percent and minus 50 percent, with a 120-minute skin time; eg. Dymonic 100 by Tremco, colours as selected by Consultant.
- .3 Weatherseal Sealant - Flashing (SEAL-EXT-FL): To ASTM C920, Type S, Grade NS, Class 25, Use NT, M, A and O; one-part, moisture curing, low modulus polyurethane sealant; accommodating joint movement of plus or minus 25 percent; eg. Dymonic by Tremco, colour as selected by Consultant.

## 2.4 GLAZING SEALANTS

- .1 Glazing Sealant (SEAL-GLZ): To CAN/CGSB-19.13-M, Type MG-2-25-A-L; one-part, moisture curing, acetoxysilicone sealant; eg. Proglaze by Tremco, Clear colour.

## 2.5 INTERIOR SEALANTS

- .1 Interior Sealant - General Purpose / Acoustical (SEAL-INT-GP): To CAN/CGSB-19.17-M; one-part, siliconized acrylic latex, mildew-resistant, accommodating joint movement of plus or minus 12-1/2 percent; eg. Tremflex 834 by Tremco, colours as selected by Consultant.
- .2 Interior Sealant - Mildew-Resistant (SEAL-INT-MR): To ASTM C920, Type S, Grade NS, Class 25, Use NT, G, A, and O; one-part, acetoxysilicone sealant, complete with integral fungicide; eg. Tremsil 200 by Tremco, colours as selected by Consultant.
- .3 Interior Sealant - Floor Tiling (SEAL-INT-FT): Premium grade, sanded siliconized acrylic; Keracaulk S by Mapei, colours to match adjacent tile grout colours.
- .4 Interior Sealant - Wall Tiling (SEAL-INT-WT): Premium grade, unsanded siliconized acrylic; Keracaulk U by Mapei, colours to match adjacent tile grout colours.

## 2.6 ACCESSORIES

- .1 Primer: Non-staining type, recommended by sealant manufacturer to suit application.
- .2 Joint Cleaner: Non-corrosive and non-staining type, recommended by sealant manufacturer; compatible with joint forming materials.
- .3 Backer Rod: Open cell polyethylene foam core wrapped in a closed cell polyethylene skin.
- .4 Bond Breaker: Pressure-sensitive tape recommended by sealant manufacturer to suit application.

## 3 Execution

### 3.1 PREPARATION

- .1 Clean and prime joints to requirements of manufacturer's instructions.
- .2 Remove loose materials and foreign matter which might impair adhesion of sealant.

### 3.2 APPLICATION

- .1 Install joint sealants to ASTM C1193.
- .2 Install acoustical sealants to ASTM C919.

- .3 Install joint sealants in direct-applied finish systems to ASTM C1481.
- .4 Apply sealant with pressure gun having proper size nozzle and extrusion nozzle where required.
- .5 Use sufficient pressure to fill joints solid to joint filler.
- .6 Shape nozzle to finish sealant in a neat concave bead.
- .7 Apply sealant sufficiently in from normal face of joints to form a positive shadow line.
- .8 Tool sealant smooth and slightly concave, free from ridges, wrinkles, air pockets and embedded impurities.
- .9 Ensure proper configuration and depth achieved. Depth of sealant at point of adhesion shall be not more than one-half the width.
- .10 Install high movement weatherseal sealant (SEAL-EXT-HM) in areas where anticipated differential movement exceeds the movement capabilities of other specified exterior weatherseal sealants.

### 3.3 FIELD QUALITY CONTROL

- .1 Inspect completed sealant joints for adhesion and cohesion to ASTM C1521.
- .2 Inspect completed sealant joints for holes, gaps, and areas where leaks could become present.
- .3 Reject failed joints, joints filled with only a skin bead, and joints having an insufficient volume of sealant.
- .4 Remove material from rejected joints, clean, and re-seal to attain proper width-to-depth joint coverage.

### 3.4 MANUFACTURER SERVICES

- .1 Arrange for sealant manufacturer's representative to be present prior to commencement of sealant installation.
- .2 Consult with manufacturer's representative as to joint conditions.
- .3 Arrange for manufacturer's representative to regularly inspect joint sealant application (minimum twice per week).
- .4 Submit written field review reports, confirming sealant installation is in strict accordance with manufacturer's recommendations.

### 3.5 CLEANING

- .1 Refer to Section 01 74 00.
- .2 Remove excess sealant and droppings using cleaner which will not damage adjacent surfaces.
- .3 Make Good surfaces defaced or disfigured as a result of sealant application.

END OF SECTION

1 General

1.1 RELATED SECTIONS

- .1 Section 04 05 10 - Masonry Mortaring and Grouting.
- .2 Section 04 22 00 - Concrete Unit Masonry.
- .3 Section 07 26 00 - Vapour Retarders.
- .4 Section 07 27 00 - Air Barriers.
- .5 Section 07 27 36 - Sprayed Foam Air Barrier.
- .6 Section 07 92 00 - Joint Sealants.
- .7 Section 08 13 13 - Hollow Metal Doors.
- .8 Section 08 14 00 - Wood Doors.
- .9 Section 08 71 00 - Door Hardware.
- .10 Section 08 80 00 - Glazing.
- .11 Section 09 21 16 - Gypsum Board Assemblies.
- .12 Section 09 90 00 - Painting and Coating.

1.2 REFERENCES

- .1 AAMA/WDMA/CSA 101/I.S. 2/A440-17: North American Fenestration Standard / Specification for Windows, Doors and Skylights.
- .2 ASTM A653/A653M-20: Standard Specification for Steel Sheet, Zinc-Coated (Galvanized) or Zinc-Iron Alloy-Coated (Galvannealed) by the Hot-Dip Process.
- .3 ASTM E283-19: Standard Test Method for Determining Rate of Air Leakage Through Exterior Windows, Curtain Walls, and Doors Under Specified Pressure Differences Across the Specimen.
- .4 CSA W59-18: Welded Steel Construction.
- .5 CSDMA Canadian Fire Labeling Guide for Commercial Steel Door and Frame Products.
- .6 CSDMA Canadian Metric Conversion Guide for Steel Doors and Frames (Modular Construction).
- .7 CSDMA Guide Specification for Installation and Storage of Hollow Metal Doors and Frames.
- .8 CSDMA Recommended Dimensional Standard for Steel Doors and Frames.
- .9 CSDMA Recommended Specifications for Commercial Steel Door and Frame Products.
- .10 NFPA 80-2007: Fire Doors and Other Opening Protectives.
- .11 ANSI/NFRC 100-2017: Procedure for Determining Fenestration Product U-factors.
- .12 ANSI/NFRC 200-2017: Procedure for Determining Product Solar Heat Gain Coefficient and Visible Transmittance at Normal Incidence.
- .13 CAN/ULC-S104-15 (R2020): Standard Method for Fire Tests of Door Assemblies.

- .14 CAN/ULC-S106-15 (R2020): Standard Method for Fire Tests of Window and Glass Block Assemblies.
- .15 ULC List of Equipment and Materials.
- 1.3 PRODUCT DATA
  - .1 Submit Product data as specified in Section 01 33 00.
  - .2 Product Data: Manufacturer's standard data sheets indicating frame components, available ratings, sizes and thicknesses.
- 1.4 SHOP DRAWINGS
  - .1 Submit Shop Drawings as specified in Section 01 33 00.
  - .2 Shop Drawings: Project-specific drawings, illustrating opening sizes, frame configurations, fire ratings, anchor types and spacings, locations of cut outs, reinforcing, and shop finishes.
- 1.5 DELIVERY, STORAGE AND HANDLING
  - .1 Refer to Section 01 60 00.
  - .2 Store Products to CSDMA Guide Specification for Installation and Storage of Hollow Metal Doors and Frames.
- 1.6 WARRANTY
  - .1 Submit extended warranty in accordance with General Conditions of the Contract.
  - .2 Extended Warranty: For a period of two years, covering against twisting, buckling, weld failure and corrosion.
- 2 Products
  - 2.1 MANUFACTURERS
    - .1 Manufacturers having Product considered acceptable for use:
      - .1 All Steel Doors 2000 Limited.
      - .2 Artek Door (1985) Limited.
      - .3 Baron Metal Industries Inc.
      - .4 Daybar Industries Limited.
      - .5 Fleming Door Products Ltd.
      - .6 Gensteel Doors.
      - .7 Metal Door Limited.
      - .8 Trillium Steel Doors Limited.
      - .9 Vision Hollow Metal Limited.
    - .2 Substitution procedures Refer to section 01 25 00

## 2.2 REGULATORY REQUIREMENTS

- .1 Fire Rated Frame Assemblies : Permanently labelled to NFPA standards for fire rated class

## 2.3 PERFORMANCE CRITERIA

- .1 Exterior Hollow Metal Frames :To AAMA/WDMA/CSA 101/I.S 2/A440,and meeting the following performance criteria.
  - .1 Air Leakage of Glazed Frames (ASTM E283):  $\leq 1.0 \text{ L/s}\cdot\text{m}^2 @ 75 \text{ Pa}$ .
  - .2 Assembly Thermal Transmittance (ANSI/NFRC 100):  $U \leq 2.15 \text{ W/m}^2 \text{ degrees C}$ .
  - .3 Assembly Solar Heat Gain Coefficient (ANSI/NFRC 200):  $\text{SHGC} \leq 0.40$ .

## 2.4 MATERIALS

- .1 Sheet Steel: To ASTM A653/A653M, Commercial Steel (CS) Type B; cold-rolled sheet steel, with regular and paintable galvanneal coatings as noted; thicknesses as indicated.
- .2 Bituminous Coating: Fibrous asphalt emulsion.
- .3 Air Sealant Foam: As specified in Section 07 27 36.
- .4 Touch-up Primer: Zinc-rich alkyd primer.
- .5 Welding Materials: To CSA W59.
- .6 Joint Sealant: As specified in Section 07 92 00, types as follows:
  - .1 Exterior Applications: Exterior weatherseal sealant, Type SEAL-EXT.
  - .2 Interior Applications: Interior general purpose sealant, Type SEAL-INT-GP.

## 2.5 MANUFACTURED UNITS

- .1 Exterior Hollow Metal Multi-Opening Frame: Sheet steel, 1.60 mm nominal coated thickness, with paintable galvanneal finish; two-piece construction with continuous thermal break; sizes and configurations as indicated on Drawings; eg. Therma-Series Frame by Fleming Door Products Ltd.
- .2 Interior Hollow Metal Door Frame: Sheet steel, 1.60 mm nominal coated thickness, with paintable galvanneal finish; fire rating as scheduled; sizes as indicated on Drawings; eg. F- Series Frame by Fleming Door Products Ltd.
- .3 Interior Hollow Metal Double Egress Door Frame: Sheet steel, 1.60 mm nominal coated thickness, with paintable galvanneal finish; fire rating as scheduled; sizes as indicated on Drawings; eg. DE-Series Frame by Fleming Door Products Ltd.
- .4 Interior Hollow Metal Multi-Opening Frame: Sheet steel, 1.60 mm nominal coated thickness, with paintable galvanneal finish; fire rating as scheduled; sizes and configurations as indicated on Drawings; eg. ST-Series Frame by Fleming Door Products Ltd.

## 2.6 ACCESSORIES

- .1 Reinforcements: Cold-rolled commercial quality steel, regular galvanneal finish, nominal coated thicknesses as follows:
  - .1 Flush Bolt, Lock and Strike Reinforcement: 1.60 mm
  - .2 Hinge Reinforcements: 3.51 mm.
  - .3 Door Closer and Holder Reinforcements: 2.74 mm.
- .2 Anchors: Cold-rolled commercial quality steel, regular galvanneal finish, nominal

coated thicknesses as follows:

- .1 T-Strap Type: 1.30 mm.
  - .2 Stirrup-strap Type: 50 x 250 mm size, 1.60 mm thick.
  - .3 Jamb Floor Type: 1.60 mm thick.
  - .4 Stud Type: 1.00 mm thick.
- .3 Jamb Spreaders: 1.00 mm nominal coated thickness, cold-rolled commercial quality steel, regular galvanized finish.
  - .4 Mortar Guard Boxes: 0.84 mm nominal coated thickness, cold-rolled commercial quality steel, regular galvanized finish.
    - Glazing Stops: Rolled steel channel shape, butted corners; prepared for countersink style tamper-proof screws.
  - .5 Threshold Saddles: Thermally broken aluminum threshold; 273x3AFG Thermal Barrier Saddle by Pemko.
  - .6 Bumpers: Resilient rubber.
  - .7 Thermal Break: Rigid neoprene or polyvinyl chloride (PVC) extrusion.

## 2.7 FABRICATION

- .1 Fabricate frames as welded units, for knock down field assembly or for drywall slip-on type, as indicated on Drawings.
- .2 Conform to CSDMA Recommended Specifications for Commercial Steel Door and Frame Products.
- .3 Fabricate fire-rated frames to CSDMA Canadian Fire Labeling Guide for Commercial Steel Door and Frame Products.
- .4 Fabricate frames with fixed/removable mullions, to profiles shown, with hardware reinforcement plates welded in place.
- .5 Welding
  - .1 Perform welding to CSA W59.
  - .2 Fill open joints, seams, and depressions with filler or by continuous brazing or welding.
  - .3 Grind exposed welds smooth and flush, to true sharp arrises and profiles.
  - .4 Sand welds to a smooth, true, uniform finish.
- .6 Mitre corners of frames. Cut frame mitres accurately and weld continuously on inside of frame.
- .7 Protect strike and hinge reinforcements and other openings with mortar guard boxes welded to frame.
- .8 Reinforce frames wider than 1 220 mm with roll formed steel channels fitted tightly into frame head, flush with top.
- .9 Fit frames with channel or angle spreaders, minimum two per frame, to ensure proper frame alignment. Install stiffener plates to spreaders between frame trim where required to prevent bending of trim and to maintain alignment when setting and during construction.
- .10 Provide adjustable T-strap anchors in frames to be installed in masonry openings, spaced at 600 mm OC.
- .11 Where frames are required to terminate at finished floor, Provide plates for anchorage to floor slab.



- .12 Prepare interior door frames for single stud door silencers, as follows:
  - .1 Single Door Frames: Three on strike jamb.
  - .2 Double Egress Door Frames: Two on head for each door leaf.
- .13 Fabricate frames and screens to accommodate scheduled glazing. Secure glazing stops to frames with counter sunk oval head sheet metal screws.
- .14 Prepare frames for scheduled door hardware and building security system devices. Blank, mortise, reinforce, drill and tap components.
- .15 Thermally-Broken Frames:
  - .1 Provide wall and floor anchors suitable for installation, purpose made not to permit thermal conductivity.
  - .2 Do not fix sections together with screws, grommets or other thermally conductive fastening device.
  - .3 Provide full frame width drip caps.
  - .4 Conform to accepted Shop Drawings.

## 2.8 FINISHES

- .1 Paintable Galvanneal Coating: To ASTM A653/A653M, ZF120 wiped zinc-iron coating, with streak-free matte grey appearance.
- .2 Regular Galvanneal Coating: To ASTM A653/A653M, ZF75 wiped zinc-iron coating, with streak-free matte grey appearance.

## 3 Execution

### 3.1 INSTALLATION

- .1 Install Products to CSDMA Guide Specification for Installation and Storage of Hollow Metal Doors and Frames.
- .2 Install Products plumb, square, aligned, without twist, and at correct elevation.
- .3 Install threshold saddles across bottom of exterior door frames.
- .4 Coordinate with masonry and wallboard construction for anchor placement.
- .5 Fill designated frames set in masonry walls and partitions solid with non-shrink grout or mortar, as specified in Section 04 05 10.
- .6 Connect exterior frames to air/vapour barrier transition sheet membranes to achieve an airtight seal.
- .7 Fill gaps between exterior frames and adjacent wall assemblies with air sealant foam, as specified in Section 07 27 36.
- .8 Seal gaps between frames and walls with joint sealant, as specified in Section 07 92 00.

END OF SECTION

1 General

1.1 RELATED SECTIONS

- .1 Section 08 12 13 - Hollow Metal Frames.
- .2 Section 08 71 00 - Door Hardware.
- .3 Section 08 80 00 - Glazing.
- .4 Section 09 90 00 - Painting and Coating.

1.2 REFERENCES

- .1 AAMA/WDMA/CSA 101/I.S. 2/A440-17: North American Fenestration Standard / Specification for Windows, Doors and Skylights.
- .2 ASTM A653/A653M-20: Standard Specification for Steel Sheet, Zinc-Coated (Galvanized) or Zinc-Iron Alloy-Coated (Galvannealed) by the Hot-Dip Process.
- .3 ASTM E283-19: Standard Test Method for Determining Rate of Air Leakage Through Exterior Windows, Curtain Walls, and Doors Under Specified Pressure Differences Across the Specimen.
- .4 CSA W59-18: Welded Steel Construction.
- .5 CSDMA Canadian Fire Labeling Guide for Commercial Steel Door and Frame Products.
- .6 CSDMA Canadian Metric Conversion Guide for Steel Doors and Frames (Modular Construction).
- .7 CSDMA Guide Specification for Installation and Storage of Hollow Metal Doors and Frames.
- .8 CSDMA Recommended Dimensional Standard for Steel Doors and Frames.
- .9 CSDMA Recommended Specifications for Commercial Steel Door and Frame Products.
- .10 NFPA 80-2007: Fire Doors and Other Opening Protectives.
- .11 ANSI/NFRC 100-2017: Procedure for Determining Fenestration Product U-factors.
- .12 ANSI/NFRC 200-2017: Procedure for Determining Product Solar Heat Gain Coefficient and Visible Transmittance at Normal Incidence.
- .13 CAN/ULC-S104-15 (R2020): Standard Method for Fire Tests of Door Assemblies.
- .14 CAN/ULC-S702.1-14 (R2019): Standard for Mineral Fibre Thermal Insulation for Buildings, Part 1: Material Specification.
- .15 CAN/ULC-S705.1-18: Standard for Thermal Insulation - Spray Applied Rigid Polyurethane Foam, Medium Density - Material Specification.
- .16 ULC List of Equipment and Materials.

1.3 PRODUCT DATA

- .1 Submit Product data as specified in Section 01 33 00.
- .2 Product Data: Manufacturer's standard data sheets, indicating materials, component sizes and thicknesses, and available finishes.

- 1.4 SHOP DRAWINGS
  - .1 Submit Shop Drawings as specified in Section 01 33 00.
  - .2 Shop Drawings: Project-specific drawings, illustrating door elevations and sizes, internal reinforcement, fire ratings, closure method, size and location of cut outs, and shop finishes.
- 1.5 DELIVERY, STORAGE AND HANDLING
  - .1 Refer to Section 01 60 00.
  - .2 Store hollow metal doors to CSDMA Guide Specification for Installation and Storage of Hollow Metal Doors and Frames.
- 1.6 WARRANTY
  - .1 Submit extended warranty in accordance with General Conditions of the Contract.
  - .2 Extended Warranty: For a period of two years, covering against twisting, buckling, delamination of steel stiffeners, weld failure and corrosion.
- 2 Products
  - 2.1 MANUFACTURERS
    - .1 Manufacturers having Product considered acceptable for use:
      - .1 All Steel Doors 2000 Limited.
      - .2 Artek Door (1985) Limited.
      - .3 Baron Metal Industries Inc.
      - .4 Daybar Industries Limited.
      - .5 Fleming Door Products Ltd.
      - .6 Gensteel Doors.
      - .7 Metal Door Limited.
      - .8 Trillium Steel Doors Limited.
      - .9 Vision Hollow Metal Limited.
    - .2 Substitution Procedures: Refer to Section 01 25 00.
  - 2.2 REGULATORY REQUIREMENTS
    - .1 Fire Rated Doors: Permanently labelled to NFPA standards for fire rated class indicated, as tested to CAN/ULC-S104.
  - 2.3 PERFORMANCE CRITERIA
    - .1 Exterior Hollow Metal Doors: To AAMA/WDMA/CSA 101/I.S. 2/A440, and meeting the following performance criteria:
      - .1 Air Leakage of Glazed Doors (ASTM E283):  $\leq 5.1 \text{ L/s}\cdot\text{m}^2 @ 75 \text{ Pa}$ .
      - .2 Assembly Thermal Transmittance (ANSI/NFRC 100):
        - .1 Glazed Doors:  $U \leq 3.94 \text{ W/m}^2 \text{ degrees C}$ .
        - .2 Opaque Doors:  $U \leq 2.56 \text{ W/m}^2 \text{ degrees C}$ .
      - .3 Assembly Solar Heat Gain Coefficient (ANSI/NFRC 200):  $\text{SHGC} \leq 0.40$ .
  - 2.4 MATERIALS
    - .1 Sheet Steel: To ASTM A653/A653M, Commercial Steel (CS) Type B; cold-rolled sheet steel, with regular and paintable galvaneal coatings as noted; thicknesses as indicated.
    - .2 Foamed-in-Place Insulation: To CAN/ULC-S705.1; injected polyurethane foam having

a LTTR thermal resistance of  $RSI \geq 0.9 @ 25 \text{ mm}$  thick.

- .3 Semi-Rigid Board Insulation: To CAN/ULC-S702.1, Type 1; mineral fibre semi-rigid board having an aged thermal resistance of  $RSI \geq 0.68 @ 25 \text{ mm}$  of thick.
- .4 Honeycomb Filler: Structural small cell kraft paper honeycomb; 36.3 kg per ream; 16.5  $\text{kg/m}^3$  minimum density; sanded to required thickness.
- .5 Temperature Rise Rated Board: Solid, non-combustible, inorganic composite board; ULC labelled; capable of limiting temperature rise on unexposed side of door in accordance with applicable regulatory requirements.
- .6 Touch-up Primer: Zinc-rich alkyd primer.
- .7 Welding Materials: To CSA W59.

## 2.5 MANUFACTURED UNITS

- .1 Exterior Hollow Metal Flush Doors: 45 mm thick, constructed as follows:
  - .1 Door Faces: Sheet steel panels, 1.30 mm nominal coated thickness, flush design, paintable galvanneal finish.
  - .2 Vertical Steel Stiffeners: Sheet steel profiles, 0.76 mm nominal coated thickness, 22 mm deep, interlocking design, regular galvanneal finish.
  - .3 Door Edges: Mechanically interlocked.
  - .4 Glazing Stops: Rolled steel channel shape, butted corners; prepared for countersunk tamper-proof screws.
  - .5 Core: Foamed-in-place insulation.
  - .6 Manufacturer and Product Name: eg. Trio-E by Fleming Door Products Ltd.
- .3 Interior Hollow Metal Flush Doors - Heavy Duty, Fire Rated: 45 mm thick, fire rating as scheduled; constructed as follows:
  - .1 Door Faces: Sheet steel panels, 1.60 mm nominal coated thickness, flush design, paintable galvanneal finish.
  - .2 Vertical Steel Stiffeners: Sheet steel profiles, 1.00 mm nominal coated thickness, 44 mm deep, interlocking design, regular galvanneal finish.
  - .3 Door Edges: Continuously welded.
  - .4 Glazing Stops: Rolled steel channel shape, butted corners; prepared for countersunk tamper-proof screws.
  - .5 Core: Semi-rigid board insulation.
- .4 Interior Hollow Metal Flush Doors - Heavy Duty, Non-Rated: 45 mm thick; constructed as follows:
  - .1 Door Faces: Sheet steel panels, 1.60 mm nominal coated thickness, flush design, paintable galvanneal finish.
  - .2 Vertical Steel Stiffeners: Sheet steel profiles, 1.00 mm nominal coated thickness, 44 mm deep, interlocking design, regular galvanneal finish.
  - .3 Door Edges: Continuously welded.
  - .4 Glazing Stops: Rolled steel channel shape, butted corners; prepared for countersunk tamper-proof screws.
  - .5 Core: Semi-rigid board insulation.

## 2.6 ACCESSORIES

- .1 Reinforcements: Commercial quality steel, regular galvanneal finish, nominal coated thicknesses as follows:
  - .1 Flush Bolt, Lock and Strike Reinforcement: 1.60 mm
  - .2 Hinge Reinforcements: 3.51 mm.

.3 Door Closer and Holder Reinforcements: 2.74 mm.

## 2.7 FABRICATION

- .1 Conform to CSDMA Recommended Specifications for Commercial Steel Door and Frame Products.
- .2 Fabricate fire-rated doors to CSDMA Canadian Fire Labeling Guide for Commercial Steel Door and Frame Products.
- .3 Provide continuous faces free from joints, tool markings and abrasions; with hardware reinforcement plates welded in place.
- .4 Welding
  - .1 Perform welding to CSA W59.
  - .2 Fill open joints, seams, and depressions with filler, or by continuous brazing, or welding.
  - .3 Grind exposed welds smooth and flush, to true sharp arrises and profiles.
  - .4 Sand welds to a smooth, true, uniform finish.
- .5 Fabricate doors to accommodate scheduled glazing. Secure glazing stops to doors with counter sunk oval head sheet metal screws.
- .6 Prepare doors for scheduled door hardware and building security system devices. Blank, mortise, reinforce, drill and tap components.
- .7 Reinforce and stiffen designated doors with vertical steel stiffeners spaced at 152 mm OC, continuous for full height of door, laminated as follows:
  - .1 Exterior Doors: To inner door face.
  - .2 Interior Doors: To both door faces.
- .8 Completely fill door cores with specified core materials.
- .9 Reinforce door edges with channel reinforcing.
- .10 Bevel stiles minimum 3 mm.
- .11 Tack Welded Door Edges: Tack weld door edge seams at 150 mm OC and fill remaining seam with body filler.
- .12 Continuously Welded Door Edges: Continuously weld door edge seams to a smooth, seamless appearance.
- .13 Mechanically Interlocked Door Edges: Mechanically interlock door edge seams with hemmed vertical edges.
- .14 Provide flush top edge and bottom closures on exterior doors, sealed watertight.

## 2.8 FINISHES

- .1 Paintable Galvanneal Coating: To ASTM A653/A653M, ZF120 wiped zinc-iron coating, with streak-free matte grey appearance.
- .2 Regular Galvanneal Coating: To ASTM A653/A653M, ZF75 wiped zinc-iron coating, with streak-free matte grey appearance.

## 3 Execution

### 3.1 INSTALLATION

- .1 Install doors to CSDMA Guide Specification for Installation and Storage of Hollow Metal Doors and Frames.

3.2 TOLERANCES

- .1 Diagonal Distortion:  $\leq 1.5$  mm measured with straight edge, corner to corner.

END OF SECTION

- 1 General
- 1.1 RELATED SECTIONS
  - .1 Section 04 22 00 - Concrete Unit Masonry.
  - .2 Section 05 50 00 - Metal Fabrications.
  - .3 Section 09 21 16 - Gypsum Board Assemblies.
  - .4 Section 09 90 00 - Painting and Coating.
- 1.2 REFERENCES
  - .1 ASTM A1008/A1008M-21: Standard Specification for Steel, Sheet, Cold-Rolled, Carbon, Structural, High-Strength Low-Alloy, High-Strength Low-Alloy with Improved Formability, Required Hardness, Solution Hardened, and Bake Hardenable.
  - .2 ASTM B221M-21: Standard Specification for Aluminum and Aluminum-Alloy Extruded Bars, Rods, Wire, Profiles and Tubes (Metric).
  - .3 ASTM E119-20: Standard Test Methods for Fire Tests of Building Construction and Materials.
  - .4 NFPA 80-2007: Fire Doors and Other Opening Protectives.
  - .5 CAN/ULC-S702.1-14 (R2019): Standard for Mineral Fibre Thermal Insulation for Buildings, Part 1: Material Specification.
  - .6 ULC List of Equipment and Materials.
- 1.3 SHOP DRAWINGS
  - .1 Submit Shop Drawings as specified in Section 01 33 00.
  - .2 Shop Drawings: Project-specific drawings, illustrating materials, profiles, accessories, locations, and dimensions.
- 1.4 CERTIFICATIONS
  - .1 Submit certification reports as specified in Section 01 33 00.
  - .2 Fire Test Certification Report: Certifying performance within specified fire rating.
- 1.5 DELIVERY, STORAGE AND HANDLING
  - .1 Refer to Section 01 60 00.
  - .2 Store Products in a dry, protected, well-vented area.
  - .3 Remove protective wrapping immediately after installation.
- 1.6 WARRANTY
  - .1 Submit extended warranty in accordance with General Conditions of the Contract.
  - .2 Manufacturer's Extended Warranty: For a period of 5 years, covering parts against defects.

2 Products

2.1 MANUFACTURERS

- .1 Manufacturers having Product considered acceptable for use:
  - .1 Acudor Access Doors.
  - .2 Bilco Canada.
  - .3 Cendrex.
  - .4 The Williams Brothers Corporation.
- .2 Gypsum Board Wall Access Panel - Non-Rated: Suitable for vertical installation in gypsum board partitions; sizes as indicated on Drawings; and meeting the following characteristics:
  - .1 Door: 1.9 mm thick sheet steel, recessed design to receive gypsum board infill.
  - .2 Box Return Frame: 1.6 mm thick sheet steel, complete with 25 mm wide, 0.61 mm thick galvanized steel perforated flange.
  - .3 Hinge: Full length piano hinge, 110 degree opening.
  - .4 Latch: Flush, stainless steel cam designed to be operated with a screwdriver.
  - .5 Manufacturer and Product Name: eg. Model WB-RDW Access Door for Drywall Surfaces by The Williams Brothers Corporation.
- .3 Gypsum Board Ceiling Access Panel - Non-Rated: Suitable for horizontal installation in gypsum board ceilings; sizes as indicated on Drawings; and meeting the following characteristics:
  - .1 Door: 2.0 mm thick extruded aluminum, complete with 16 mm thick moisture resistant gypsum board infill, brush gasket, and safety chain.
  - .2 Box Return Frame: 2.0 mm thick extruded aluminum, concealed flange of depth to match adjacent ceiling board thickness.
  - .3 Hinge: Concealed pivot hinge, allowing for door removal.
  - .4 Latch: Push to open latch.
  - .5 Manufacturer and Product Name: eg. Model WB-NTG Recessed Drywall Access Door by The Williams Brothers Corporation.
- .4 Masonry Wall Access Panel - Fire-Rated: 1-1/2 hour B-label with maximum temperature rise of 110 degrees C; suitable for both horizontal or vertical installation; and meeting the following characteristics:
  - .1 Door and Trim: 48 mm deep, 1.9 mm thick sheet steel, with rolled safety edge on inside of door; insulated with non-rigid mineral fibre insulation, completely filling door cavity.
  - .2 Return Frame: 1.5 mm thick sheet steel, complete with 4 masonry strap anchors.
  - .3 Closer: Automatic, spring-type.
  - .4 Hinge: Continuous piano hinge, 180 degree opening.
  - .5 Latch: Self-latching keyed cylinder paddle latch, opposite hinge.
  - .6 Manufacturer and Product Name: eg. Model WB-FR Premium Ultra Fire-Rated Access Door by The Williams Brothers Corporation.
- .5 Masonry Wall Access Panel - Non-Rated: Suitable for both horizontal or vertical installation in masonry or concrete partitions or bulkheads; and meeting the following characteristics:
  - .1 Door: 1.9 mm thick sheet steel.
  - .2 Return Frame: 1.2 mm thick sheet steel, complete with 4 masonry strap anchors.
  - .3 Hinge: Fully concealed, piano type.
  - .4 Latch: Flush, stainless steel cam designed to be operated with a screwdriver.
  - .5 Manufacturer and Product Name: eg. Model WB-GP Premium General Purpose Access Door by The Williams Brothers Corporation.



2.5 FINISHES

- .1 Aluminum: Standard factory mill finish.
- .2 Baked Enamel Primer on Steel: Electrostatically-applied baked enamel primer over rust-inhibiting phosphate treatment; paintable; Gray colour.

3 Execution

3.1 PREPARATION

- .1 Coordinate installation of access panels in masonry walls with Section 04 22 00.
- .2 Coordinate installation of access panels in gypsum board partitions and ceilings with Section 09 21 16.
- .3 Coordinate locations of access panels with facility services Subcontractors.

3.2 INSTALLATION

- .1 Install Products straight, plumb, and level; flush with adjacent surfaces.
- .2 Install Products for long life under hard use.

END OF SECTION

1 General

1.1 **SECTION INCLUDES**

- .1 Labour, Products, equipment and services necessary for finish hardware work in accordance with the Contract Documents.
- .2 Supply and installation of brass construction cores.

1.2 **REFERENCES**

- .1 BHMA, Builders Hardware Manufacturing Association.
- .2 NFPA 80, Standard for Fire Doors and Other Opening Protectives.

1.3 **SUBMITTALS**

- .1 Product data: Submit manufacturer's Product data in accordance with the Conditions of the Contract indicating compliance with reference standards, transportation, storage, handling and installation requirements.
- .2 Shop Drawings:
  - .1 Submit Shop Drawings and 3 complete hardware lists in accordance with the Conditions of the Contract indicating:
    - .1 Door locations, sizes, hardware manufacturer's catalogue numbers, finish symbols and quantities required.
    - .2 Locations and mounting heights of each type of hardware.
  - .2 Supply templates and required information to door and frame manufacturer to enable accurate sizes, locations of cut-outs and reinforcement for hardware.
  - .3 Submit templates to required trade to arrange for provisions for accurate setting and fitting of hardware.
- .3 Samples:
  - .1 Submit 2 samples in accordance with the Conditions of the Contract of each item that is different from hardware specified and include manufacturer's parts lists and installation instructions.
  - .2 Submit hardware component samples illustrating style, colour and finish. Tag samples identifying applicable Specification article number, brand name and number, finish, building location, date and catalogue number.
  - .3 Do not order hardware until samples have been accepted. Submit new samples to replace rejected samples. Supply hardware and finishes identical to each accepted sample.
- .4 Closeout submittals:
  - .1 Submit the following in accordance with the Conditions of the Contract for each Product for incorporation into Operation and Maintenance Manual:
    - .1 Maintenance data.
    - .2 Operating instructions and safety precautions.

- .3 Parts list with name and address of supplier.
- .4 Lubrication schedule and type of lubricant recommended.
- .5 Keys, tools and special devices.
- .6 Inspection procedures related to preventive maintenance.

#### **1.4 QUALITY ASSURANCE**

- .1 General:
  - .1 Manufacturers: Companies specializing in manufacturing door hardware and registered with BHMA.
  - .2 Hardware supplier: Company specializing in supplying commercial door hardware and acceptable to the manufacturer from the list of TDSB pre-approved suppliers:
    - 1. City Wide Hardware
    - 2. Commercial Doors and Hardware
    - 3. Empire Hardware Co. Ltd.
    - 4. Rivett Hardware
    - 5. Upper Canada Hardware
- .2 Certifications:
  - .1 Employ an Architectural Hardware Consultant to inspect completed installation and certify that hardware has been installed in accordance with manufacturer's printed instructions, Authorities having Jurisdiction and as specified.
  - .2 Submit manufacturer's certificate that finish hardware and fire rated hardware meets specified requirements.

#### **1.5 DELIVERY, STORAGE, AND HANDLING**

- .1 Be responsible for packaging of hardware, on a set by set basis. As material is received from various manufacturers identify it to correspond to Hardware List symbols.
- .2 Label packages legibly, indicating manufacturer's number, types, sizes, opening number and Hardware List reference number. Wrap hardware and include in package, screws, bolts and fastening necessary for correct installation. If hardware package is not complete, pay additional charges incurred by installer.
- .3 Deliver hardware to Site packaged, labelled and cross-referenced to hardware list for each item and its scheduled installation location.
- .4 Accept Products of this Section on Site and ensure that each item is undamaged.
- .5 Catalogue and store hardware in secure area.

#### **2 Products**

#### **2.1 GENERAL**

- .1 Provide hardware schedule to Consultant for approval indicating products, materials and finishes. Do not order products until schedule has been approved by Consultant.
- .2 Carefully check and verify Hardware List against Contract Drawings to ensure that hardware listed can be used as specified. Inform Consultant of concerns regarding quality, quantity, operation or function of hardware selected:
  - .1 Verify hand of doors, examine details on Contract Drawings and at Site to ensure hardware supplied can be correctly installed and is correct for Work as constructed.
  - .2 Select hardware in accordance with applicable codes and regulations and to approval of local Fire Marshal.
  - .3 Replace and pay for defective hardware including hardware which was incorrectly selected, and remedial and installation costs.
- .3 Ensure that hardware selected will function correctly, meets Contract requirements and Ontario Building Code and authorities having jurisdiction.
- .4 Ensure that each hardware item is of same type, design and by same manufacturer.
- .5 Manufacturer's names or trade marks are not permitted on exposed surfaces of hardware.
- .6 Include in packing slip a list of parts, name of supplier and door number in which lock is to be installed.
- .7 Hardware for fire rated and labelled door and frame assemblies: ULC listed or as accepted by authorities having jurisdiction.
- .8 Fire rated assemblies:
  - .1 Hardware: Selected and installed in accordance with applicable codes and regulations, NFPA-80 and to approval of [Ontario] Fire Marshal.
  - .2 Fire rated doors: ULC labelled hardware. Submit written certification of conformance to ULC requirements for each type of hardware prior to delivery.
  - .3 Locksets and latchsets on fire rated doors: 19 mm throw minimum.

## **2.2 ACCESSORIES**

- .1 Items to be attached to masonry or concrete with expandable shields, lag screws, bolts or other fastening devices as required. Exposed screws: Stainless steel, Phillips or Robertson heads.

## **2.3 FINISHES**

- .1 Metal finishes: Free from defects, clean, unstained and of a uniform colour for each type of finish required. Exposed surfaces and anchors: Specified finish symbol of item.

3 Execution

3.1 **EXAMINATION**

- .1 Verify condition and dimensions of previously installed Work upon which this Section depends. Report defects to Consultant. Commencement of Work means acceptance of existing conditions.

3.2 **INSTALLATION**

- .1 Install hardware in accordance with reviewed Shop Drawings, manufacturer's installation instructions, and applicable Codes and regulations.
- .2 Install hardware in accordance with hardware templates.
- .3 Adjust fixed and operable hardware for correct clearances and function.
- .4 Mount hardware measured from finished floor to centre of hardware, unless indicated otherwise or required by Code:
- .1 Top hinge: 250 mm from head of door to top.
  - .2 Bottom hinge: 265 mm from finished floor to bottom of hinge.
  - .3 Intermediate hinge: Equal distance between top and bottom hinge.
  - .4 Locksets, latchsets: 1000 mm.
  - .5 Panic device crossbar: 1000 mm.
  - .6 Push plates: 1100 mm to bottom of plates.
  - .7 Guard bars: 1100 mm.
  - .8 Door pulls: 1100 mm to bottom of pulls.
  - .9 Blank strike: 1450 mm.
  - .10 Blank fronts: 1450 mm.
- .5 Include for supply and installation of wiring for electric strikes from electrical junction box to electric strike hardware.
- .6 Locate door stops to contact doors 75 mm from latch edge.
- .7 Install hardware and trim square and plumb to doors.
- .8 Replace wrappings for hardware provided by manufacturer after installation.
- .9 Safeguard keys to keep them out of unauthorized hands, tag them with door number, and deliver them to person designated by Consultant at building completion.

3.3 **FIELD QUALITY CONTROL**

- .1 Have hardware inspected after installation by hardware supplier's representative, obtain certification in writing that hardware has been supplied and installed in accordance with Specifications and hardware manufacturer's instructions and is functioning correctly.

.2 Inspect fire rated openings to ensure they are installed in compliance with NFPA 80 requirements and Authorities having Jurisdiction.

.3 Test access control system and electrified hardware devices for proper operation. Verify electric door release hardware operates properly upon activation of fire alarm system.

### 3.4 **ADJUSTING**

.1 Verify under work of this Section, that installed hardware functions properly.

.2 Adjust hardware so that latches and locks operate smoothly and without binding, and closers act positively with the least possible resistance in use. Lubricate hardware if required by manufacturer's instructions.

.3 Adjust doors with self closing devices or automatic closing devices for proper operation after the HVAC system is balanced and adjusted. Verify spring power of non sized door closers is properly adjusted.

### 3.5 **CLEANING**

.1 Remove wrappings at completion of the Project and clean hardware in accordance with manufacturer's instructions.

### 3.6 **HARDWARE SCHEDULE**

.1 Refer to Hardware Schedule appended to the specification.

END OF SECTION

1 General

1.1 RELATED SECTIONS

- .1 Section 03 30 00 - Cast-in-Place Concrete.
- .2 Section 04 22 00 - Concrete Unit Masonry.
- .3 Section 05 40 00 - Cold-Formed Metal Framing.
- .4 Section 06 16 43 - Gypsum Sheathing.
- .5 Section 06 20 00 - Finish Carpentry.
- .6 Section 07 92 00 - Joint Sealants.
- .7 Section 08 12 13 - Hollow Metal Frames.
- .8 Section 08 31 00 - Access Door and Panels.
- .9 Section 09 30 00 - Tiling.
- .10 Section 09 51 23 - Acoustical Tile Ceilings.
- .11 Section 09 81 00 - Acoustic Insulation.
- .12 Section 09 90 00 - Painting and Coating.
- .13 Section 21 13 13 - Wet Pipe Fire Suppression.
- .14 Section 23 37 13 - Diffusers, Registers, and Grilles.
- .15 Section 26 51 13 - Lighting Equipment.

1.2 REFERENCES

- .1 ASTM A641/A641M-19: Standard Specification for Zinc-Coated (Galvanized) Carbon Steel Wire.
- .2 ASTM A653/A653M-20: Standard Specification for Steel Sheet, Zinc-Coated (Galvanized) or Zinc-Iron Alloy-Coated (Galvannealed) by the Hot-Dip Process.
- .3 ASTM A792/A792M-21a: Standard Specification for Steel Sheet, 55% Aluminum-Zinc Alloy- Coated by the Hot-Dip Process.
- .4 ASTM C475/C475M-17: Standard Specification for Joint Compound and Joint Tape for Finishing Gypsum Board.
- .5 ASTM C514-04(2020): Standard Specification for Nails for the Application of Gypsum Board.
- .6 ASTM C645-18: Standard Specification for Nonstructural Steel Framing Members.
- .7 ASTM C754-20: Standard Specification for Installation of Steel Framing Members to Receive Screw-Attached Gypsum Panel Products.
- .8 ASTM C840-20: Standard Specification for Application and Finishing of Gypsum Board.
- .9 ASTM C954-18: Standard Specification for Steel Drill Screws for the Application of

Gypsum Panel Products or Metal Plaster Bases to Steel Studs From 0.033 in. (0.84 mm) to 0.112 in. (2.84 mm) in Thickness.

- .10 ASTM C1002-20: Standard Specification for Steel Self-Piercing Tapping Screws for Application of Gypsum Panel Products or Metal Plaster Bases to Wood Studs or Steel Studs.
- .11 ASTM C1047-19: Standard Specification for Accessories for Gypsum Wallboard and Gypsum Veneer Base.
- .12 ASTM C1178/C1178M-18: Standard Specification for Coated Glass Mat Water-Resistant Gypsum Backing Panel.
- .13 ASTM C1264-19: Standard Specification for Sampling, Inspection, Rejection, Certification, Packaging, Marking, Shipping, Handling, and Storage of Gypsum Panel Products.
- .14 ASTM C1396/C1396M-17: Standard Specification for Gypsum Board.
- .15 ASTM C1629/C1629M-19: Standard Classification for Abuse-Resistant Nondecorated Interior Gypsum Panel Products and Fiber-Reinforced Cement Panels.
- .16 ASTM C1658/C1658M-19e1: Standard Specification for Glass Mat Gypsum Panels.
- .17 ASTM E90-09(2016): Standard Test Method for Laboratory Measurement of Airborne Sound Transmission Loss of Building Partitions and Elements.
- .18 CGC Gypsum Construction Handbook.
- .19 CAN/CGSB-71.25-M88: Adhesive, for Bonding Drywall to Wood Framing and Metal Studs.
- .20 CISCA Ceiling Systems Handbook, 2012 Edition.
- .21 GA-214-2015: Recommended Levels of Finish for Gypsum Board, Glass Mat and Fiber- Reinforced Gypsum Panels.
- .22 GA-226-2019: Application of Gypsum Board to Form Curved Surfaces.
- .23 CAN/ULC-S101-14 (REV1): Standard Method of Fire Endurance Tests of Building Construction and Materials.
- .24 ULC List of Equipment and Materials.

### 1.3 QUALIFICATIONS

- .1 Installers: A firm specializing in erecting metal support framing and installing gypsum board, and having minimum 5 years documented experience.
- 2. Delegated Design: Engage a qualified Specialty Structural Engineer to design cold-formed steel framing. Provide Engineer stamped drawings for stud framing design.

### 1.4 DELIVERY, STORAGE AND HANDLING

- .1 Conform to ASTM C1264.

### 2 Products



## 2.1 MANUFACTURERS

- .1 Manufacturers of metal framing having Product considered acceptable for use:
  - .1 Bailey Metal Products Limited.
  - .2 CGC Inc.
  - .3 Dietrich Metal Framing.
- .2 Manufacturers of gypsum board and coated tile backer board having Product considered acceptable for use:
  - .1 CertainTeed Canada, Inc.
  - .2 CGC Inc.
  - .3 G-P Gypsum Corporation.
- .3 Substitution Procedures: Refer to Section 01 25 00.

## 2.2 DESCRIPTION

- .1 Interior Partitions: Vertical non-load bearing metal stud framing clad with wall boards mechanically-fastened or adhered on one or both sides, and including acoustical insulation and accessories where indicated.
- .2 Suspended Ceilings: Horizontal non-load bearing channels and framing carrying mechanically-fastened ceiling boards, and including acoustical insulation and accessories where indicated.
- .3 A non-load bearing (non-structural) member is defined as a member in a steel-framed system which is limited to transverse (out-of-plane) load of not more than 480 Pa, a superimposed axial load, exclusive of sheathing materials, of not more than 1 460 N/m, or a superimposed axial load of not more than 890 N.
- .4 A load bearing (structural) stud may be used in a non-load bearing application; however, non-load bearing members (studs or track) may never be used in a load bearing (axial or lateral loading) application.

## 2.3 PERFORMANCE CRITERIA

- .1 Provide metal wall framing systems with maximum design limit of 240 Pa and maximum allowable deflection of L/360.
- .2 Provide metal ceiling framing systems with maximum allowable deflection of L/240.
- .3 Fire-Resistance Rated Assemblies: Provide Products and construction identical to those tested in the listed assemblies; to CAN/ULC-S101.
- .4 Sound Rated Assemblies: Provide Products and construction identical to those tested in listed assemblies; to ASTM E90.

## 2.4 METAL FRAMING

- .1 Metal Studs and Tracks - Standard Duty: To ASTM C645; 0.455 mm thick sheet steel; galvanized or galvalume finish; C-Shape with 32 mm wide flange, complete with serrated faces and knock-outs for electrical fitments; depths as indicated on Drawings.
- .2 Metal Studs and Tracks - Heavy Duty: To ASTM C645; 0.836 mm thick sheet steel; galvanized or galvalume finish; C-Shape with 32 mm wide flange, complete with serrated faces and knock-outs for electrical fitments; depths as indicated on Drawings.
- .3 Structural Steel Studs: Conforming to ASTM C955, 14ga, 16ga, 18ga hot dipped

galvanized steel sheet; flanges minimum 1 1/4" (32mm) edge bent back 90 degrees and doubled to form 1/4" (6mm) minimum return. Face to be knurled. Width 4" or 6" (100mm or 150mm) nominal unless otherwise noted on drawings.

- .4 Metal Shaft Wall Studs: To ASTM C645; 0.836 mm thick sheet steel; galvanized or galvalume finish; CH- and E-Shapes, complete with serrated faces and knock-outs for electrical fitments; depths as indicated on Drawings.
- .5 Metal Deflection Track: To ASTM C645; 0.455 mm thick sheet steel; galvanized or galvalume finish; U-Shape with long legs, designed to accommodate structural deflections; depths as indicated on Drawings.
- .6 Furring Members: To ASTM C645; 0.455 mm thick sheet steel; galvanized or galvalume finish; and as described below:
  - .1 C-Shaped Furring Channels: 13 mm wide flange, 19 mm deep unless noted otherwise on Drawings.
  - .2 Hat-Shaped Furring Channels: 13 mm wide flange, 22 mm deep unless noted otherwise on Drawings.
  - .3 Z-Shaped Furring: With slotted or non-slotted web, 32 mm face flange, 22 mm wall attachment flange; depth as indicated on Drawings.
  - .4 Resilient Furring Channels: Designed to reduce sound transmission; 13 mm deep unless noted otherwise on Drawings.
- .7 Carrying Channels: To ASTM C754; 1.37 mm thick cold-formed steel with galvanized or galvalume finish; having minimum yield strength of 228 MPa; C-Shape with 13 mm flange width, 38 mm deep unless noted otherwise on Drawings.
- .8 Furring Brackets: 0.79 mm thick sheet steel; galvanized or galvalume finish; adjustable, with corrugated-edge.
- .9 Flat Strap and Backing Plates: 0.455 mm thick sheet steel; galvanized or galvalume finish; lengths and widths as indicated on Drawings.
- .10 Channel Bridging: 0.455 mm thick sheet steel; galvanized or galvalume finish; 13 mm wide flange, 19 mm deep unless noted otherwise on Drawings.
- .11 Hanger Wire: To ASTM A641/A641M; zinc-coated, soft-annealed, 3.77 mm OD steel wire.
- .12 Tie Wire: To ASTM A641/A641M; zinc-coated, soft-annealed, 1.21 mm OD steel wire.

## 2.5 BOARDS

- .1 Gypsum Board - Moisture/Mould Resistant (GB-MR-1): To ASTM C1396/C1396M, Type X; 15.9 mm thick Type X gypsum panel with water- and mould-resistant gypsum core and paper facers, tapered edges; eg. Sheetrock Brand Mold Tough Panels FireCode X by CGC Inc.
- .2 Gypsum Board - Fire-Rated (GB-FR): To ASTM C1396/C1396M, Type C; fire-rated gypsum panel with water- and mould-resistant gypsum core and paper facers, tapered edges, ULC labelled; thicknesses as indicated on Drawings; eg. Sheetrock Brand Mold Tough Panels FireCode C by CGC Inc.
- .3 Gypsum Board - Abuse-Resistant (GB-AR): To ASTM C1629/C1629M, Type X; Level II - Mild to Moderate Duty; 15.9 mm thick gypsum abuse-resistant panel with water- and mould-resistant gypsum core and paper facers, tapered long edges and square ends; eg. Sheetrock Brand Panels Mold Tough AR FireCode X by CGC Inc.
- .4 Gypsum Board - Shaft Liner (GB-SL): To ASTM C1658/C1658M, Type X; 25 mm thick; double bevelled edges; silicone treated gypsum core, with coated glass mat facers both

sides; eg. Sheetrock Brand Glass-Mat Liner Panels by CGC Inc.

- .5 Gypsum Board - Ceiling Board (GB-CLG): To ASTM C1396/C1396M; 12.7 mm thick; gypsum panel with water- and mould-resistant, paper- facers, eased edges; maximum 6.5 kg/m<sup>2</sup> weight; eg. Sheetrock Brand Ultralight Interior Ceiling Board Sag-Resistant by CGC Inc.

## 2.6 ACCESSORIES

- .1 Foam Gasket: 3.2 mm thick adhesive-backed, closed-cell vinyl foam strips that allow fastener penetration without foam displacement; width to suit track depth.
- .2 Corner Beads, Casing Beads, Control Joints and Edge Trim: To ASTM C1047; metal type.
- .3 Reveals and Trim Reglets: To ASTM C1047; extruded aluminum profiles; as indicated on Drawings.
- .4 Nail Fasteners: To ASTM C514; galvanized steel.
- .5 Steel Drill Screws: To ASTM C954; galvanized steel.
- .6 Self-Tapping Screws: To ASTM C1002, Type S, Fine Thread; galvanized steel.
- .7 Adhesive: To CAN/CGSB-71.25-M.
- .8 Joint Tape - Mould Resistant: Fiberglass joint tape, 50 mm wide, self-adhering type; eg. Mould Resistant Fiberglass Drywall Tape by CGC Inc.
- .9 Joint Compound - Mould Resistant: Ready-mixed drying type drywall compound, to ASTM C475/C475M; eg. Synko Brand Classic All Purpose Drywall Compound by CGC Inc.
- .10 Acoustic Insulation: Mineral fibre acoustical batt insulation, as specified in Section 09 81 00.
- .11 Sealant: Interior general purpose / acoustical sealant, Type SEAL-INT-GP as specified in Section 07 92 00.
- .12 Water: Potable.

## 2.7 MIXING

- .1 Thoroughly mix joint and skim coat materials to a homogenous mixture, of trowel able consistency.

## 2.8 FINISHES

- .1 Galvanized Coating on Metal Framing Components: To ASTM A653/A653M, Z120 hot dipped zinc alloy coating.
- .2 Galvalume Coating on Metal Framing Components: To ASTM A792/A792M, AZM150 hot dipped aluminum-zinc alloy coating.

## 3 Execution

### 3.1 PREPARATION

- .1 Suspended Assemblies: Coordinate installation of suspension systems with installation of overhead structure.
  - .1 Ensure inserts and other provisions for anchorages to building structure have

been installed to receive hangers at required spacings.

- .2 Supply concrete inserts and other devices to other related Sections for installation in advance.
- .2 Before sprayed fireproofing is applied, attach offset anchor plates or ceiling track to surfaces designated to receive sprayed fireproofing. Where offset anchor plates are required, Provide continuous plates fastened to structure at maximum 600 mm OC.
- .3 Once sprayed fireproofing has been applied, remove them only to the extent necessary for installation of non-load bearing steel framing. Do not reduce thickness for sprayed fireproofing below that required for fire-resistance ratings indicated. Protect adjacent sprayed fireproofing from damage.

### 3.2 METAL WALL FRAMING

- .1 Install metal wall framing to ASTM C754 and CGC Gypsum Construction Handbook.
- .2 Where metal framing is installed directly against exterior masonry walls or dissimilar metals at exterior walls, Provide foam gasket between metal framing and exterior wall.
- .3 Install studs such that flanges within framing system point in same direction.
- .4 Space metal studs along straight runs at maximum 400 mm OC.
- .5 Install track floors and overhead supports. Extend framing full height to structural supports or substrates above suspended ceilings, except where partitions are indicated to terminate at suspended ceilings. Continue framing around ducts penetrating partitions of structure.
- .6 Where framing extends to overhead structural supports, Provide deflection track to create a slip-type head joints to produce joints at tops of framing system that prevent axial loading of finished assemblies due to deflection of structure.
- .7 Screw vertical studs at door opening jambs to jamb anchor clips at door frames. Install track section for cripple studs at head and secure to jamb studs.
  - .1 Provide two studs at each jamb.
  - .2 Provide cripple studs at head adjacent to each jamb stud, with minimum 13 mm clearance from jamb stud to allow for installation of control joint in finished assembly.
- .8 Provide framing below sills of openings to match framing required above opening heads.
- .9 Fire-Resistance-Rated Partitions:
  - .1 Install framing to comply with fire-resistance-rated assembly indicated.
  - .2 Support closures and make partitions continuous from floor to underside of solid structure.
- .10 Sound-Rated Partitions: Install framing to comply with sound-rated assembly indicated.
- .11 Curved Partitions: Conform to GA-226, as follows:
  - .1 Bend track to uniform curve and locate straight lengths so they are tangent to arcs.
  - .2 Begin and end each arc with a stud, and space intermediate studs equally along arcs.
  - .3 Provide studs spaced at 150 mm OC.
  - .4 On straight lengths of not less than two studs at ends of arcs, place studs at 150 mm OC.
- .12 Direct Furring: Attach furring to concrete or masonry with stub nails, screws designed

for masonry attachment, or power-driven fasteners spaced at 610 mm OC.

- .13 Z-Furring Members:
  - .1 Erect insulation vertically and hold in place with Z-furring members spaced at 610 mm OC.
  - .2 Except at exterior corners, securely attach narrow flanges of furring members to wall with concrete stub nails, screws designed for masonry attachment, or power-driven fasteners spaced at 610 mm OC.
  - .3 At exterior corners, attach wide flange of furring members to wall with short flange extending beyond corner; on adjacent wall surface, screw-attach short flange of furring channel to web of attached channel.
  - .4 At interior corners, space second member no more than 305 mm from corner and butt insulation to fit.
- .14 Unless indicated otherwise, Provide supplementary framing and furring to conceal pipes, conduit and ducts.
- .15 Provide supplementary framing and blocking to support fixtures, equipment services, heavy trim, grab bars, toilet accessories, furnishings and similar construction.
- .16 Install bracing at terminations in assemblies.
- .17 Do not bridge building control joints and expansion joints with non-load bearing steel framing members. Frame both sides of joints independently.
- .18 Installation Tolerances: Install framing members so fastening surfaces vary not more than 3 mm from plane formed by faces of adjacent framing members.

### 3.3 SUSPENDED CEILING FRAMING

- .1 Install ceiling framing to ASTM C754 and CISCA installation standards.
- .2 Isolate suspension system from building structure. Prevent transfer of loading imposed by structural movement.
- .3 Install hangers plumb and free from contact with insulation or other objects within ceiling plenum.
- .4 Size supplemental suspension members and hangers to support ceiling loads within established performance limits.
- .5 Where width of ducts and other construction within ceiling plenum produces hanger spacings that interfere with locations of hangers required to support standard suspension system members, install supplemental suspension members and hangers in the form of trapezes or similar devices.
- .6 Secure wire hangers by looping and wire tying, either directly to structure or to inserts, eye screws, or other devices and fasteners that are secure and appropriate for substrate; and in a manner that will not cause hangers to fail or deteriorate.
- .7 Do not attach hangers to steel roof decking, or to rolled-in hanger tabs of composite steel floor decking.
- .8 Do not attach hangers to permanent metal forms. Furnish cast-in-place hanger inserts that extend through forms.
- .9 Do not connect or suspend steel framing from ducts, pipes or conduit.

- .10 For fire-resistance-rated assemblies, wire tie furring channels to supports.
- .11 Installation Tolerances: Level to within 3 mm in 3 600 mm, measured lengthwise on each member that will receive finishes and transversely between parallel members that will receive finishes.

### 3.4 ACOUSTICAL ACCESSORIES

- .1 Install resilient channels at maximum 600 mm OC.
- .2 Place acoustical insulation in partitions tight within spaces, around cut openings, behind and around electrical and mechanical items within or behind partitions, and tight to items passing through partitions.
- .3 Install acoustical sealant within designated sound-rated partitions.

### 3.5 BOARD INSTALLATION

- .1 Install board Products to ASTM C840 and the CGC Gypsum Construction Handbook.
- .2 Install gypsum ceiling board perpendicular to supports.
- .3 Screw fasten boards to furring or framing.
- .4 Install abuse-resistant gypsum board on heavy duty metal stud and track framing.
- .5 Install shaft liner gypsum board on metal shaft wall stud and track framing.
- .6 Install flexible gypsum board on curved walls using multiple layers to achieve total thickness indicated on Drawings.
- .7 Double Layer Applications: Use gypsum backing board for first layer, place perpendicular to framing or furring members. Place second layer perpendicular to first layer.
- .8 Place corner beads at external corners. Place edge trim where gypsum board abuts dissimilar materials. Fasten with nail attachment, unless specified otherwise.
- .9 Provide bulkheads where changes of ceiling or height occur.
- .10 Install access panels when and where directed by affected Subcontractors. Refer to Section 08 31 00.

### 3.6 BOARD FINISHING

- .1 Tape, fill, and sand exposed joints, edges, and corners to a smooth surface.
- .2 Leave surfaces smooth, even, plumb and true, ready to receive final finishes specified in other Sections.
- .3 Except as specified below, finish gypsum board to GA-214, Level 4.
  - .1 Provide Level 1 finish on concealed surfaces, such as in plenum spaces above ceilings, and behind casework.
  - .2 Provide Level 2 finish on surfaces designated to receive tile finishes.
  - .3 Provide Level 5 finish on glass mat faced gypsum surfaces designated to receive a painted finish.

### 3.7 CONTROL JOINTS

- .1 Provide control joints where indicated on Drawings, and where:

- .1 Ceiling, partition or furring abuts a structural element,
  - .2 Ceiling, partition or furring abuts dissimilar construction,
  - .3 Construction changes within plane of the partition or ceiling,
  - .4 Partition or furring run exceeds 9 000 mm,
  - .5 Ceiling dimensions exceed 15 000 mm in either direction,
  - .6 Wings of "L-", "U-" and "T"-shaped ceiling areas are joined, and
  - .7 Expansion or control joints occur in the structural elements of the building.
- .2 Break continuity of gypsum board and framing system at control joints.
  - .3 Provide continuous control joint profile.
- 3.8 RELIEF JOINTS
- .1 Provide relief joints where indicated on Drawings, and where gypsum board assemblies abut dissimilar construction.
  - .2 Stop gypsum board 6 mm from abutting construction at dissimilar building elements, unless indicated otherwise.
  - .3 Provide a thermal break where gypsum board comes into contact with frames. Adhere self- adhering tape to casing bead and compress during installation of gypsum board.
  - .4 Provide reveal mouldings where gypsum board ceilings meet curved wall surfaces, and where indicated on Drawings.

END OF SECTION

1 General

1.1 RELATED SECTIONS

- .1 Section 03 30 00 - Cast-in-Place Concrete.
- .2 Section 04 22 00 - Masonry.
- .3 Section 06 10 00 - Rough Carpentry.
- .4 Section 07 92 00 - Joint Sealants.
- .5 Section 09 21 16 - Gypsum Board Assemblies.
- .6 Section 09 65 19 - Resilient Tile Flooring.

1.2 REFERENCES

- .1 ANSI A108.01-2016: General Requirements: Subsurface and Preparations by Other Trades.
- .2 ANSI A108.4-2009: Installation of Ceramic Tile with Organic Adhesives or Water Cleanable Tile-Setting Epoxy Adhesive.
- .3 ANSI A108.5-1999: Installation of Ceramic Tile with Dry-Set Portland Cement Mortar or Latex-Portland Cement Mortar (Reaffirmed 2010).
- .4 ANSI A108.10-1999: Installation of Grout in Tilework (Reaffirmed 2010).
- .5 ANSI A108.13-2005: Installation of Load Bearing, Bonded, Waterproof Membrane for Thin- Set Ceramic Tile and Dimension Stone (Reaffirmed 2016).
- .6 ANSI A108.17-2005: Installation of Crack Isolation Membranes for Thin-Set Ceramic Tile and Dimension Stone (Reaffirmed 2016).
- .7 ANSI A118.1-2012: Specifications for Dry-Set Portland Cement Mortar.
- .8 ANSI A118.4-2012: Specifications for Modified Dry-Set Cement Mortar.
- .9 ANSI A118.7-2010: Specifications for Polymer Modified Cement Grouts for Tile Installation (Reaffirmed 2016).
- .10 ANSI A118.10-2014: Specifications for Load Bearing, Bonded, Waterproof Membranes for Thin-Set Ceramic Tile and Dimension Stone Installation.
- .11 ANSI A118.12-2014: Specifications for Crack Isolation Membranes for Thin-Set Ceramic Tile and Dimension Stone Installation.
- .12 ANSI A136.1-2008: Specifications for Organic Adhesives for Installation of Ceramic Tile (Reaffirmed 2013).
- .13 ANSI A137.1-2012: Specifications for Ceramic Tile.
- .14 ASTM C144-18: Standard Specification for Aggregate for Masonry Mortar.
- .15 ASTM C207-18: Standard Specification for Hydrated Lime for Masonry Purposes.
- .16 ASTM C627-18: Standard Test Method for Evaluating Ceramic Floor Tile Installation Systems Using the Robinson-Type Floor Tester.
- .17 ASTM C847-18: Standard Specification for Metal Lath.
- .18 ASTM F1869-16a: Standard Test Method for Measuring Moisture Vapor Emission Rate of Concrete



Subfloor Using Anhydrous Calcium Chloride.

- .19 ASTM F3191-16: Standard Practice for Field Determination of Substrate Water Absorption (Porosity) for Substrates to Receive Resilient Flooring.
- .20 CAN/CGSB-25.20-95: Surface Sealer for Floors.
- .21 CSA A3001-18: Cementitious Materials for Use in Concrete.
- .22 TTMAC Specification Guide 09 30 00 - Tile Installation Manual 2019-2021.

### 1.3 SHOP DRAWINGS

- .1 Submit Shop Drawings as specified in Section 01 33 00.
- .2 Shop Drawings: Project-specific drawings, illustrating swim lines, terminal, targets, pool markings, and special patterns. Include locations and details for proposed control joints.

### 1.4 SAMPLES

- .1 Submit samples as specified in Section 01 33 00.
- .2 Verification Samples: A 300 x 300 mm size panel, complete with selected grout colour; mounted to 19 mm thick plywood backer.

### 1.5 CLOSEOUT SUBMITTALS

- .1 Submit closeout submittals as specified in Section 01 78 00.
- .2 Maintenance Data: Latest edition of TTMAC Hard Surface Maintenance Guide; sufficient quantities for inclusion in the operation and maintenance manuals.

### 1.6 EXTRA STOCK MATERIALS

- .1 Supply extra stock materials as specified in Section 01 78 00.
- .2 Extra Stock Materials: Two percent or 4.0 m<sup>2</sup>, whichever is the greater, of each type and colour of installed tile; clearly marked to identify:
  - .1 Manufacturer's name,
  - .2 Product's name,
  - .3 Product colour and pattern.
- .3 Package tiles neatly in original containers, to prevent damage.

### 1.7 QUALIFICATIONS

- .1 Installers: Skilled mechanics trained and experienced in tiling, and members of TTMAC.

### 1.8 DELIVERY STORAGE AND HANDLING

- .1 Refer to Section 01 60 00.
- .2 Store Products in a dry area, protected from freezing, staining and damage.
- .3 Store cementitious materials on a dry surface.

### 1.9 AMBIENT CONDITIONS

- .1 Do not install tiles at temperatures less than 12 degrees C.
- .2 Maintain temperatures at or above 12 degrees C until cementitious materials have fully cured.

## 2 Products

### 2.1 MANUFACTURERS

- .1 Manufacturers of mortars, grouts and adhesives having Product considered acceptable for use:
  - .1 Custom Building Products.
  - .2 Flextile.
  - .3 Laticrete.
  - .4 Mapei.
  - .5 Proma Adhesives, Inc.
  - .6 TEC.
- .2 Manufacturers of tile-setting accessories having Product considered acceptable for use:
  - .1 Bengard.
  - .2 Profilitec.
  - .3 Schlüter Systems (Canada) Inc.
- .3 Substitution Procedures: Refer to Section 01 25 00.

### 2.2 PERFORMANCE CRITERIA

- .1 Traffic Level Performance (ASTM C627): Moderate Class.

### 2.3 TILE MATERIALS

- .1 Porcelain Floor Tile (PFT-1): To ANSI A137.1; 300 x 300 mm size, 9 mm thick matte finish porcelain tile; complete with bullnose caps and trim; Spectra Series (Small Grain) as distributed by Olympia Tile International, or Vitra Dotti Series as distributed by Centura Floor and Wall Fashions, or Porcelain as distributed by Daltile; premium colours as selected by Consultant, up to maximum 3 colours.
- .2 Ceramic Wall Tile (CET): To ANSI A137.1; 102 x 407 mm (4" x 16") size; 9.3mm thick. Daltile "Linear Color Wheel" collection complete with all trim pieces, or approved alternate. Colour: To Architect's future selection from full range of colours. Allow for 25% contrasting colour for pattern to later detail. Allow up to 3 neutral colours and 4 accent colours.
- .3 Tactile Walking Surface Indicator - Porcelain Floor Tile (TWSI-PFT): To ANSI A137.1; 297 x 297 mm size, 10 mm thick porcelain floor tile, complete with 4 mm high, 22 mm OD truncated domes spaced at 60 mm OC; Elan Tile as distributed by Kinesik Engineered Products Inc., colour as selected by Consultant.

### 2.4 MORTAR MATERIALS

- .1 Portland Cement: To CSA A3001, Type GU.
- .2 Hydrated Lime: To ASTM C207, Type N-Normal.
- .3 Sand: To ASTM C144, passing 16 mesh.
- .4 Dry-Set Portland Cement Mortar: To ANSI A118.1.
- .5 Latex-Portland Cement Mortar: To ANSI A118.4.

### 2.5 GROUT MATERIALS

- .1 Cementitious Grout: To ANSI A118.7; rapid setting type, polymer-modified sanded grout. Acceptable products:
  - 1. Ultracolor Plus FA by Mapei, colours as selected by Consultant.
  - 2. Tec Power Grout (550) by H.B. Fuller Construction Products, colours as selected by Consultant.

## 2.6 ACCESSORIES

- .1 Crack Isolation Membrane: To ANSI A118.12, High Performance Rating; loadbearing membrane.
- .2 Reinforcing Mesh: 50 x 50 mm size; 1.6 mm thick steel wire mesh; welded fabric, galvanized.
- .3 Metal Lath: To ASTM C847; 1.4 kg/m<sup>2</sup> galvanized steel lath.
- .4 Tape: 50 mm fibre mesh tape, as recommended by backer board manufacturer.
- .5 Organic Adhesive: To ANSI A136.1; Type 1 for wet areas and Type 2 for dry areas.
- .6 Latex Additive: Formulated for use in portland cement mortars and grout.
- .7 Water: Clean, cold and potable.
- .8 Joint Sealant: As specified in Section 07 92 00, Types as follows:
  - .1 Floor Tiling: Type SEAL-INT-FT.
  - .2 Wall Tiling: Type SEAL-INT-WT.
- .9 Tile Sealer: To CAN/CGSB-25.20, Type 1 - Penetrating.

## 2.7 MANUFACTURED COMPONENTS AND ACCESSORIES

- .1 Edge and Transition Strips: Roll-formed stainless steel edge strips, 3 mm wide at top edge; with integral perforated anchoring leg for setting the strip into the setting material; height as required; Brushed finish; eg. SCHIENE-EB by Schlüter Systems (Canada) Inc.
- .2 Tapered Transition Strips - To Other Floor Finishes: Roll-formed stainless steel transition strips; profile and height as indicated; with integral perforated anchoring leg for setting the strip into the setting material; sloped transition and decorative edge strip for transition from tile to lower finish; Brushed finish; eg. RENO-EBU by Schlüter Systems (Canada) Inc.
- .3 Edge Strips at Recessed Tile Floors: Roll-formed stainless steel transition strips; with integral perforated anchoring leg for setting the strip into the setting material; height as required; eg. DECO-E by Schlüter Systems (Canada) Inc.
- .4 Stair Nosings: Extruded thermoplastic rubber, heavy-traffic use, slip-resistant stair nosing set into extruded aluminum support section with integral perforated anchoring leg for setting the assembly into the setting material; 52 mm wide, height as indicated; colour as selected by Consultant; complete with end-caps; eg. TREP-B by Schlüter Systems (Canada) Inc.
- .5 Decorative Edge Trim: Extruded aluminum decorative edge trim with integral perforated anchoring leg for setting the strip into the setting material; complete with pre-formed corners; Satin Anodized finish; eg. RONDEC-DB 14 AE by Schlüter Systems (Canada) Inc.
- .6 Expansion and Control Joints for Thin-Set Applications: Roll formed stainless steel profiles joined by a soft CPE movement joint material, with integral perforated anchoring legs for setting the joint into the setting bed; height as required to suit application; insert colour as selected by Consultant; eg. DILEX-EKSN by Schlüter Systems (Canada) Inc.
- .7 Waterproofing Membrane System: To ANSI A118.10; soft polyethylene membrane with fleece webbing laminated on both sides; use special cut-width rolls and special shapes for corners and pipe sleeves; KERDI by Schlüter Systems (Canada) Inc.

## 2.8 MIXES

- .1 Scratch Coat (by volume): One part Portland cement, 4 parts sand, and latex additive where required by TTMAC Detail. Premixed mortar may be used per manufacturer's instructions. Adjust water volume depending on moisture content of sand to obtain consistency and workability.
- .2 Slurry Bond Coat: Mix Portland cement and water to a creamy paste consistency. Include latex additive where required by TTMAC Detail.
- .3 Levelling Coat (by volume): One part Portland cement, 4 parts sand, and latex additive where required by TTMAC Detail. Premixed mortar may be used per manufacturer's instructions.

## 3 Execution

### 3.1 EXAMINATION

- .1 Refer to Section 01 71 00.
- .2 Ensure substrates have been prepared to ANSI A108.01.
- .3 Ensure substrate surfaces are clean, dimensionally stable, cured and free of contaminants such as oil, sealers and curing compounds.
- .4 Ensure concrete has cured for minimum 28 days.
- .5 Ensure concrete floors have not been treated with proprietary curing compounds.
- .6 Ensure concrete floors have been steel trowelled to a fine broom finish.
- .7 Ensure concrete slabs have been finished with a maximum permissible variation of 3 mm in 3 000 mm from the required plane, and not more than 1.5 mm in 305 mm when measured from high points in the surface.
- .8 Conduct moisture vapour emission rate (MVER) tests on concrete slabs-on-fill to ASTM F1869. Do not proceed with flooring installation until tests indicate maximum 1.45 kg per 100 m<sup>2</sup> for a 24 hour period.
- .9 Determine absorptive nature of substrates by conducting porosity tests to ASTM F3191.

### 3.2 PREPARATION

- .1 Protect surrounding work from damage or disfiguration.
- .2 Thoroughly clean existing surfaces which are to receive tile finish to ensure removal of grease, oil and dust film.
- .3 Prepare substrate as recommended by manufacturer for absorptive conditions determined by porosity test.
- .4 Apply a latex modified cementitious levelling coat wherever concrete slab does not meet specified tolerance for flatness and levelness, and where slight irregularities exist. Limit levelling coat thickness to less than 8 mm.
- .5 Install crack isolation membrane over suspended concrete slabs to ANSI A108.17. If crack isolation membrane is applied over rough surface, apply a 6 mm thick sand-bed under crack isolation membrane.
- .6 Waterproofing Membrane: To ANSI A108.13, and as follows:
  - .1 Fully adhere waterproof membrane to substrate with tile setting adhesive, with no air pockets.
  - .2 Overlap and seal membrane seams a minimum 50 mm.

- .3 Alternately, tightly butt adjacent sheets and cover with a 125 mm strip of waterproofing membrane sealed to primary membranes.
  - .4 Provide strips of waterproofing where required to span expansion joints or terminate waterproofing into movement-joint type tile-setting accessories, as detailed per manufacturer's instructions.
  - .5 Adhere waterproofing membrane to fixtures, joints around pipes, door and window frames, etc. with transparent waterproof sealant.
- .7 Cover backer board joints with fibre mesh tape set in latex-Portland cement mortar.

### 3.3 INSTALLATION

- .1 Feather floor for seamless transition between different finishes as indicated on drawings.
- .2 Install Products to TTMAC Specification Guide 09 30 00, as scheduled below.
- .3 Apply tile using water-resistant organic adhesives to ANSI A108.4.
- .4 Apply tile using dry-set Portland cement mortar or latex-Portland cement mortar beds to ANSI A108.5.
- .5 Install tiles with straight, uniform joints, to tile manufacturers' recommended joint widths.
- .6 Fit tile units around corners, fittings, fixtures, drains and other built-in objects to maintain uniform joint appearance.
- .7 Make cut edges smooth, even and free from chipping. Do not split tile.
- .8 Lay out tiles according to patterns indicated on Drawings. Ensure perimeter and cut tiles are minimum half size.
- .9 Set tiles in place while bond coat is wet and tacky, prior to skinning over. Slide tile back and forth to ensure a proper bond and level surface. Avoid lippage.
- .10 Clean backs of tiles and back butter tiles to ensure a 95 percent bond coverage.
- .11 Clean excess mortar from surface prior to final set.
- .12 Sound tiles after setting materials have cured and replace hollow sounding tile before grouting.
- .13 Exterior Surfaces and Wet Areas (Thin Set Method): Notch adhesive in straight lines, backbutter tile and set on freshly trowelled thin-set mortar. Move tile back and forth perpendicular to notches.
- .14 Ungauged Slate, Marble, Stone and Large Ceramics: Immediately prior to setting, backbutter tile through a push box or box screed to achieve a uniform thickness of tile and mortar.
- .15 Install site-cut tiles with site-cut edges concealed within either a grouted joint or a metal trim.  
Visually expose only factory-made edges.
- .16 Keep two-thirds the depth of grout joints free of setting material.

### 3.4 MOVEMENT JOINTS

- .1 Install control and expansion joints to TTMAC Detail 301MJ.
- .2 Keep control joints and expansion joints free of setting materials.
- .3 In addition to the guidelines outlined in TTMAC Specification Guide 09 30 00, Provide movement joints over cold joints, saw cuts, at columns and at wall plane changes.

### 3.5 TILE-SETTING ACCESSORIES INSTALLATION

- .1 Install tile-setting accessories in continuous lengths, to level straight lines by pressing the perforated anchoring leg of the accessory solidly into the tile setting adhesive.
- .2 Butt ends of units tightly together with hairline joint. Trowel an additional layer of tile setting material over the anchored leg of the accessory prior to placement of tiles.
- .3 Unless specified otherwise, solidly embed tiles over anchoring leg of installed trim with surface of tile flush with top of tile-setting accessories.
- .4 Leave 3 mm joint between tile and tile-setting accessories for filling with grout.
- .5 Install pre-formed corners, end-caps and trim at changes in direction and at terminations.  
Mitered joints will be rejected.
- .6 Expansion and Control Joints: Solidly embed tiles over installed edge strips with joint surface either flush with top of joint or 1 mm below top of tile.

### 3.6 GROUTING

- .1 Allow proper setting time prior to grouting.
- .2 Preseal tiles requiring protection from grout staining.
- .3 Apply cementitious grout to ANSI A108.10.
- .4 Force grout into joints to ensure dense finish.
- .5 Remove excess and polish with clean cloths.

### 3.7 FIELD QUALITY CONTROL

- .1 Inspect completed work and replace broken, cracked, or damaged tile.

### 3.8 TOLERANCES

- .1 Level tiles to conform to a 1 mm tolerance over a 3 mm joint.

### 3.9 CLEANING

- .1 Refer to Section 01 74 00.
- .2 Apply tile sealer to floor tiles.

### 3.10 PROTECTION

- .1 Protect finished areas from traffic until setting materials have sufficiently cured.
- .2 Protect grouted areas from traffic for 24 hours after grouting.
- .3 Provide protective covering until Owner occupancy.
- .4 Protect wall tiles and bases from impact, vibration, heavy hammering on adjacent and opposite walls for at least 14 days after installation.

### 3.11 SCHEDULE

- .1 Tile Installed Over Masonry or Concrete Walls - Thin-Set Method: TTMAC Detail 303W.
- .2 Tile Installed Over Gypsum Board - Thin-Set Method: TTMAC Detail 304W.
- .3 Tile Installed on Coated Glass Mat Backer Board: TTMAC Detail 305W (B - Interior Wet/Dry Areas).
- .4 Tile Bonded to Concrete Slab - Thin-Set Method: TTMAC Detail 311F (A - Interior/Exterior), (C - Crack

Concrete Interior/Exterior - Full Coverage) or (D - Uncoupling Over Green/Young Concrete).

- .5 Tile Applied Over Wood Subfloor in Dry Areas - Thin-Set Method: TTMAC Detail 313F (A - Thin-Set on Plywood).
- .6 Large Format Tile on Interior Floors: TTMAC Detail 329 LFT.
- .7 Large Format Tile on Interior Walls: TTMAC Detail 330 LFTW.

END OF SECTION

1 General

1.1 RELATED SECTIONS

- .1 Section 09 21 16 - Gypsum Board Assemblies.
- .2 Section 09 54 23 - Linear Metal Ceilings.
- .3 Section 09 81 00 - Acoustic Insulation.
- .4 Section 09 84 13.13 - Fixed Sound-Absorptive Cementitious Panels.
- .5 Section 21 13 13 - Wet Pipe Fire Suppression.
- .6 Section 23 37 13 - Diffusers, Registers, and Grilles.
- .7 Section 26 51 13 - Lighting Equipment.

1.2 REFERENCES

- .1 ASTM A123/A123M-17: Standard Specification for Zinc (Hot-Dip Galvanized) Coatings on Iron and Steel Products.
- .2 ASTM A153/A153M-16a: Standard Specification for Zinc Coating (Hot-Dip) on Iron and Steel Hardware.
- .3 ASTM A641/A641M-19: Standard Specification for Zinc-Coated (Galvanized) Carbon Steel Wire.
- .4 ASTM C635/C635M-17: Standard Specification for Manufacture, Performance, and Testing of Metal Suspension Systems for Acoustical Tile and Lay-in Panel Ceilings.
- .5 ASTM C636/C636M-19: Standard Practice for Installation of Metal Ceiling Suspension Systems for Acoustical Tile and Lay-In Panels.
- .6 ASTM E84-21a: Standard Test Method for Surface Burning Characteristics of Building Materials.
- .7 ASTM E1264-19: Standard Classification for Acoustical Ceiling Products.
- .8 Cisca Ceiling Systems Handbook, 2012 Edition.
- .9 CAN/ULC-S102-2018 (REV1): Standard Method of Test for Surface Burning Characteristics of Building Materials and Assemblies.
- .10 ULC List of Equipment and Materials.

1.3 SAMPLES

- .1 Submit samples as specified in Section 01 33 00.
- .2 Verification Samples: Duplicate 140 x 290 mm size sample of each specified acoustic lay-in tile, indicating texture, pattern, colour and edge profile.

1.4 EXTRA STOCK MATERIALS

- .1 Supply extra stock materials as specified in Section 01 78 00.
- .2 Extra Stock Materials: Minimum two full bundles for each lay-in tile ceiling Product, colour and pattern; clearly marked to identify:



- .1 Manufacturer's name,
  - .2 Product's name,
  - .3 Product colour and pattern.
- .3 Store bundles in original undamaged packages, in a warm, dry area.
- 1.5 QUALIFICATIONS
  - .1 Installers: A firm specializing in erecting suspended ceiling grid and installing lay-in tile ceiling systems, and having minimum 3 years documented experience.
- 1.6 DELIVERY, STORAGE AND HANDLING
  - .1 Refer to Section 01 60 00.
  - .2 Deliver Products undamaged original containers.
  - .3 Store Products in warm, dry area.
- 2 Products
- 2.1 MANUFACTURERS
  - .1 Manufacturers having Product considered acceptable for use:
    - .1 Armstrong World Industries.
    - .2 CertainTeed Canada, Inc.
    - .3 CGC Inc.
    - .4 Rockfon.
  - .2 Substitution Procedures: Refer to Section 01 25 00.
- 2.2 MATERIALS
  - .1 Acoustic Ceiling Tile (ACT-1): To ASTM E1264, Type III, Form 2, Pattern C E; wet-formed mineral fiber non-sagging lay-in tile, complete with anti-mould and mildew treatment, and sag resisting treatment; as follows:
    - .1 Size: 610 x 1 220 mm.
    - .2 Thickness: 15 mm.
    - .3 Pattern: Medium texture, non-directional fissured.
    - .4 Edge: Square.
    - .5 Finish: Factory-applied latex paint, White colour.
    - .6 Fire Resistance (CAN/ULC-S102): Class A.
    - .7 Weight: 3.42 kg/m<sup>2</sup>;
    - .8 Noise Reduction Coefficient: 0.55.
    - .9 Light Reflectance: 0.84.
  - .3 Manufacturer and Product Name: eg. Fine Fissured - 1729 by Armstrong World Industries.
  - .2 Fire Rated Acoustic Panels (ACT-2): To ASTM E1264, Type III, Form 2, Pattern C E; wet-formed mineral fiber non-sagging lay-in tile, complete with anti-mould and mildew treatment, and sag resisting treatment; as follows:
    - 1. CAN2-92.1M, 600mm x 1200mm
    - 2. Thickness:15mm thick,
    - 3. Pattern: Colour white, pattern to match existing;
    - 4. Manufacturer and product: to match existing; No substitutions accepted.
    - 5. Provide complete system to meet required fire resistance rating including hold down clips and fire-rated protection boxes for recessed light fixtures where required, as per

ULC BXUV D216 assembly listing.

- .4 Suspended Ceiling Grid: To ASTM C635/C635M, Class HD and ICC-ESR-1308, commercial quality, cold rolled steel, non-fire rated; main tees, cross tees and grid adapters with exposed 24 mm T-shape, 43 mm high; die cut and interlocking components; baked enamel finish; eg. Prelude XL by Armstrong World Industries.
- .5 For **Fire Rated** assemblies the suspended ceiling grid as per BXUV D216 assembly listing.  
(1hr fire rating assembly at exiting classrooms)
- .6 Accessories: Stabilizer bars, clips, splices, edge mouldings, caps, cross tree plugs, threaded studs, and hold down clips required for suspended grid system; same material and finish as suspended grid.
- .7 Fire Rated light enclosures as required. e.g. TENMAT Inc. fire protection solutions.
- .8 Grid Mounting Yoke: SmartFit Yoke by CertainTeed Canada, Inc.
- .9 Support Channels and Hangers: Galvanized steel, to rigidly secure ceiling system with maximum deflection of L/360.
- .10 Hanger Wire: To ASTM A641/A641M; zinc-coated, soft-annealed, 3.77 mm OD steel wire.
- .11 Tie Wire: To ASTM A641/A641M; zinc-coated, soft-annealed, 1.21 mm OD steel wire.

2.3 FINISHES

- .1 Galvanized Coating on Steel Components: To ASTM A123/A123M, Z275 hot dipped zinc alloy coating.
- .2 Galvanized Coating on Steel Hardware: To ASTM A153/A153M, Class B2 hot dipped zinc alloy coating.
- .3 Baked Enamel Coating on Ceiling Grid and Trim: One coat of zinc oxide primer sprayed and baked followed by two coats of semi-gloss enamel sprayed and baked; White colour.

3 Execution

3.1 EXAMINATION

- .1 Refer to Section 01 71 00.
- .2 Verify layout of hangers will not interfere with other work.
- .3 Verify ducts, pipes, fittings and other penetrations have been properly installed.

3.2 SUSPENDED CEILING GRID SYSTEM

- .1 Install suspended ceiling grid system to ASTM C636/C636M, and CISCA installation standards.
- .2 Provide grid mounting yoke to facilitate installation of suspended ceiling grid system.
- .3 Provide support channel and hanger assemblies necessary for suspended planks.
- .4 Suspend planks from support assembly using caps, cross tree plugs, and threaded studs, mounted at height above finished floor as indicated on Drawings.

- .5 Hang ceiling grid directly from structural elements, independent of walls, columns, metal deck, ducts, pipe fittings and conduit. Provide additional support channels and hangers as required.
- .6 Space hangers at maximum 1220 mm OC along supporting grillage, and not more than 150 mm OC from ends. Do not place hangers in front of access panels.
- .7 Where ducts or other equipment prevent regular spacing of hangers, reinforce nearest affected hangers to span the extra distance.
- .8 Install additional hangers and reinforcing to accommodate loads being carried.
- .9 Provide suspension hanger at each corner of suspended fixtures, and at maximum 610 mm OC around perimeter of fixture.
- .10 Locate ceiling grid system on room axis leaving equal border units according to reflected ceiling plan.
- .11 Install main tees suspended at maximum 1 220 mm OC and maximum 600 mm from wall.
- .12 Install cross tees and grid adapters perpendicular to main tees, and interlock with main tees.
- .13 Frame around fixtures and openings.
- .14 Install edge moulding at intersection of ceiling and vertical surfaces.
- .15 Form expansion joints as detailed. Form to accommodate plus or minus 25 mm movement. Maintain visual closure.

### 3.3 LAY-IN TILE

- .1 Fit lay-in tiles in place, free from damaged edges.
- .2 Neatly cut lay-in tiles to accommodate necessary penetrations.
- .3 Cut and rabbet lay-in tiles at border areas and vertical surfaces.
- .4 Lay directional patterned units one way with pattern parallel to longest room axis. Fit border neatly against abutting surfaces.
- .5 Install hold-down clips to retain lay-in tiles tight to grid system within 6 000 mm of an exterior door.

### 3.4 TOLERANCES

- .1 Variation from Flat and Level Surface: 3 mm in 3 000 mm.

END OF SECTION

1 General

1.1 RELATED SECTIONS

- .1 Section 04 22 00 - Concrete Unit Masonry.
- .2 Section 09 21 16 - Gypsum Board Assemblies.
- .3 Section 09 30 00 - Tiling.
- .4 Section 09 65 16 - Resilient Sheet Flooring.
- .5 Section 09 65 19 - Resilient Tile Flooring.

1.2 REFERENCES

- .1 ASTM F1861-21: Standard Specification for Resilient Wall Base.
- .2 ASTM F2169-15(2020): Standard Specification for Resilient Stair Treads.

1.3 SAMPLES

- .1 Submit samples as specified in Section 01 33 00.
- .2 Selection Samples: Duplicate 100 mm long sample sets, illustrating manufacturer's complete line of available colour selections.

1.4 CLOSEOUT SUBMITTALS

- .1 Submit closeout submittals as specified in Section 01 78 00.
- .2 Maintenance Data: Manufacturer's standard maintenance and cleaning guidelines; sufficient quantity for inclusion in operation and maintenance manuals.

1.5 EXTRA STOCK MATERIALS

- .1 Supply extra stock materials as specified in Section 01 78 00.
- .2 Extra Stock Materials: Three percent or 6 m<sup>2</sup>, whichever is greater, of each Product, colour and pattern; clearly marked to identify:
  - .1 Manufacturer's name,
  - .2 Product's name,
  - .3 Product colour and pattern.
- .3 Package Products neatly in original containers, to prevent damage.

1.6 DELIVERY, STORAGE AND HANDLING

- .1 Refer to Section 01 60 00.
- .2 Deliver and store Products undamaged in original wrapping or cartons.
- .3 Store Products for minimum 3 days prior to installation in a warm, dry room; stacked not more than four boxes high.

1.7 AMBIENT CONDITIONS

- .1 Maintain ambient air temperature of 20°C three days prior to, during, and 48 hours after installation of flooring materials.
- .2 Maintain ambient air relative humidity between 35 percent and 55 percent RH.

- .3 Do not install Products in conditions of high humidity or where exposed to cold drafts.
- .4 In hot weather, protect Products from direct sunlight.
- .5 Provide adequate ventilation.

## 2 Products

### 2.1 MANUFACTURERS

- .1 Manufacturers having Product considered acceptable for use:
  - .1 Armstrong World Industries.
  - .2 Roppe Corporation.
  - .3 Tarkett Johnsonite.
- .2 Substitution Procedures: Refer to Section 01 25 00.

### 2.2 MATERIALS

- .1 Resilient Base (RB-STR): To ASTM F1861, Type TP, Group 1, Style A - Straight; 3.2 mm thick thermoplastic rubber, 102 mm high; top set; colours as selected by Consultant.
- .2 Resilient Base (RB-COVE): To ASTM F1861, Type TP, Group 1, Style B - Cove; 3.2 mm thick thermoplastic rubber, 102 mm high; top set; complete with pre-moulded end stops and external corners; colours as selected by Consultant.
- .3 Transition Strips (TS): Thermoset vulcanized rubber, smooth, purpose made to accommodate wheeled traffic and prevent tripping; tapered designs to suit nature of transition; colours as selected by Consultant.
- .4 Resilient Stair Tread and Riser (RSTR): To ASTM F2169, Type TS, Class 1, Group 1; 6 mm thick thermoset vulcanized rubber one-piece stair tread and riser with raised round texture; complete with 50 mm wide co-extruded visually-impaired strip; VIRNRDTR by Tarkett Johnsonite, colour as selected by Consultant.
- .5 Resilient Stair Riser (RSR): To ASTM F2169, Type TP, Class 1, Group 1; thermoplastic rubber one-piece stair riser; Smooth texture; eg. RR-XX by Tarkett Johnsonite, colour as selected by Consultant.
- .6 Resilient Stair Nosing (RSN): To ASTM F2169, Type TV, Class 1, Group 1; 4.76 mm thick thermoplastic vinyl nosing with 75 mm horizontal return and 55 mm return down edge of tread, full width of stair tread in one piece; Smooth pattern; complete with 50 mm wide co-extruded visually-impaired strip; eg. VIRCN-XX-B by Tarkett Johnsonite, colour as selected by Consultant.

### 2.3 ADHESIVES

- .1 Adhesive for Resilient Base, Trim and Accessories: Non-flammable, solvent free contact adhesive, neoprene water-based formulation, Off-white colour; eg. Johnsonite #946 Premium Contact Adhesive by Tarkett Johnsonite.
- .2 Adhesive for Resilient Stair Treads and Risers: Water based acrylic adhesive, White colour; eg. Johnsonite #965 Flooring and Tread Adhesive by Tarkett Johnsonite.

### 2.4 ACCESSORIES

- .1 Filler: Premixed latex filler, White colour.
- .2 Primers: Acrylic, waterproof type; as recommended by manufacturer.

- .3 Sealers and Wax: As recommended by manufacturer.
- 3 Execution
- 3.1 EXAMINATION
  - .1 Refer to Section 01 71 00.
  - .2 Verify surfaces are dry, true, even and smooth, and free of gaps, holes and depressions.
  - .3 Verify surfaces are free of paint, grease and oil.
- 3.2 PREPARATION
  - .1 Clean substrate to remove deleterious matter which would impair adhesion of Products.
  - .2 Prepare substrate to a smooth and flat surface, as follows:
    - .1 Remove ridges and bumps by grinding or other means.
    - .2 Fill low spots, cracks, joints, holes, and other defects with filler.
    - .3 Apply, trowel and float filler to leave smooth, flat, hard surface.
    - .4 Prohibit traffic until filler is cured.
    - .5 Vacuum clean substrate.
  - .3 Prime substrates to ensure proper adhesion of Products.
- 3.3 INSTALLATION
  - .1 Install Products on solid backing.
  - .2 Bond Products tight to surfaces.
  - .3 Mitre internal corners.
  - .4 At exposed ends and external corners, conform to the following:
    - .1 Coved Base: Use pre-moulded units.
    - .2 Straight Base: V-cut back of base strip to two-thirds of its thickness, and fold to desired shape.
  - .5 Scribe and fit base to door frames and other interruptions.
  - .6 Install combination stair treads and risers in single pieces covering full width, depth and height of stair tread and riser.
  - .7 Install stair risers to lowest riser in each stair run, single piece for entire width and height of riser.
  - .8 Install stair nosings in single pieces covering full width of landing edge.
- 3.4 CLEANING
  - .1 Refer to Section 01 74 00.
  - .2 Clean, seal and wax installed Products.
- 3.5 PROTECTION
  - .1 Refer to Section 01 76 00.
  - .2 Protect completed installation with suitable and durable materials until Ready-for-Takeover.

END OF SECTION

1 General

1.1 RELATED SECTIONS

- .1 Section 03 30 00 - Cast-in-Place Concrete.
- .2 Section 03 40 00 - Precast Concrete Slabs.
- .3 Section 03 41 23 - Precast Concrete Stairs.
- .4 Section 09 30 00 - Tiling.
- .5 Section 09 65 13 - Resilient Base and Accessories.
- .6 Section 09 65 16 - Resilient Sheet Flooring.

1.2 ALLOWANCES

- .1 Contract Price includes a stipulated sum cash Allowance, as specified in Section 01 21 00.
- .2 Cash Allowance: Cost for supply and installation of custom graphic symbols fabricated from vinyl composition tile and set in Gymnasium floor.

1.3 REFERENCES

- .1 ASTM F710-21: Standard Practice for Preparing Concrete Floors to Receive Resilient Flooring.
- .2 ASTM F1066-04(2018): Standard Specification for Vinyl Composition Floor Tile.
- .3 ASTM F1700-20: Standard Specification for Solid Vinyl Floor Tile.
- .4 ASTM F1869-16a: Standard Test Method for Measuring Moisture Vapor Emission Rate of Concrete Subfloor Using Anhydrous Calcium Chloride.
- .5 ASTM F2170-19a: Standard Test Method for Determining Relative Humidity in Concrete Floor Slabs Using in situ Probes.
- .6 ASTM F3191-16: Standard Practice for Field Determination of Substrate Water Absorption (Porosity) for Substrates to Receive Resilient Flooring.

1.4 SHOP DRAWINGS

- .1 Submit Shop Drawings as specified in Section 01 33 00.
- .2 Shop Drawings: Project-specific drawings, illustrating game line and custom graphic symbol layouts, noting locations, colours and thicknesses.

1.5 SAMPLES

- .1 Submit samples as specified in Section 01 33 00.
- .2 Selection Samples: Duplicate 300 x 300 mm size samples of each specified Product, illustrating manufacturer's complete line of available colours and patterns.

1.6 CLOSEOUT SUBMITTALS

- .1 Submit closeout submittals as specified in Section 01 78 00.
- .2 Maintenance Data: Manufacturer's standard maintenance and cleaning guidelines; sufficient quantity for inclusion in operation and maintenance manuals.

## 1.7 EXTRA STOCK MATERIALS

- .1 Supply extra stock materials as specified in Section 01 78 00.
- .2 Extra Stock Materials: Three percent or 6 m<sup>2</sup>, whichever is greater, of each resilient flooring Product, colour and pattern; clearly marked to identify:
  - .1 Manufacturer's name,
  - .2 Product's name,
  - .3 Product colour and pattern.
- .3 Package tile products neatly in original containers, to prevent damage.

## 1.8 DELIVERY, STORAGE AND HANDLING

- .1 Refer to Section 01 60 00.
- .2 Deliver and store Products undamaged in original wrapping or cartons.
- .3 Store Products for a minimum of three days prior to installation in warm dry room with boxes stacked not over four high.

## 1.9 AMBIENT CONDITIONS

- .1 Maintain ambient air temperature of 20 degrees C three days prior to, during, and 48 hours after installation of flooring materials.
- .2 Maintain ambient air relative humidity between 35 percent and 55 percent RH.
- .3 Do not lay flooring in conditions of high humidity or where exposed to cold drafts.
- .4 In hot weather, protect flooring from direct sunlight.
- .5 Provide adequate ventilation.

## 2 Products

### 2.1 MANUFACTURERS

- .1 Manufacturers of vinyl composition tile having Product considered acceptable for use:
  - .1 Armstrong World Industries.
  - .2 Mannington.
  - .3 Tarkett Johnsonite.
- .2 Manufacturers of luxury vinyl tile having Product considered acceptable for use:
  - .1 American Biltrite Flooring.
  - .2 Gerflor.
  - .3 Tarkett Johnsonite.
- .3 Manufacturers of rubber tile having Product considered acceptable for use:
  - .1 Armstrong World Industries.
  - .2 Mondo.
  - .3 Roppe Corporation.
  - .4 RCA Rubber Company.
  - .5 Tarkett Johnsonite.
- .4 Manufacturers of tactile walking surface indicator tile having Product considered acceptable for use:
  - .1 Tarkett Johnsonite.
- .5 Substitution Procedures: Refer to Section 01 25 00.



## 2.2 MATERIALS

- .1 Vinyl Composition Tile (VCT): To ASTM F1066, Composition 1, Class 2; 3.2 mm thick, 305 x 305 mm size reinforced resilient vinyl tile; multiple colours as selected by Consultant.
  - a) Field Tile: 12" x 12" x 1/8" thick tile by Armstrong – Standard Excelon – Imperial texture. Final Colour to approval of Architect. Vinyl floor tile to match existing for repair work.
  - b) Accent Tile: 12" x 12" x 1/8" thick tile by Tarkett “Expressions” or approved alternate. Colour to be selected by Architect from FULL LINE. Allow for 25% of floor areas, deep colour accent bands / patterns including fancy cuts, including curves, include for up to 8 accent colours per floor area.
- .2 Luxury Vinyl Tile (LVT): To ASTM F1700, Class III, Type B - Embossed; as follows:
  - .1 Plank Size: As selected by Consultant.
  - .2 Total Thickness: 2.5 mm.
  - .3 Wear Layer Thickness: 0.7 mm
  - .4 Colours: As selected by Consultant.
  - .5 Product and Manufacturer Names: Mirra Wood by American Biltrite Flooring, or Creation 70 by Gerflor, or ID Inspiration 70 by Tarkett Johnsonite.
- .3 Rubber Tile Flooring (RTF): To ASTM F1344, Class 1-B; and as follows:
  - .1 Size: 610 x 610 mm.
  - .2 Thickness: 3.2 mm.
  - .3 Texture: Hammered.
  - .4 Colour: As selected by Consultant.
  - .5 Hardness (ASTM D2240, Shore A):  $\geq 85$ .
  - .6 Abrasion Resistance (ASTM D3389):  $< 1.0$  gm weight loss.
  - .7 Slip Resistance (ASTM D2047): Static coefficient of friction  $\geq 0.8$ .
  - .8 Manufacturer and Product Name: eg. HRTSP-XX ColorSplash Rubber Floor Tiles by Tarkett Johnsonite.
- .4 Tactile Walking Surface Indicators - Rubber Tile (TWSI-RT): To ASTM F1344, Class 1-A and 1-B; 610 x 610 mm size, 3.2 mm thick rubber tile, complete with 4 mm high truncated domes evenly spaced over tile surface; Safe Sense Tactile Walking Surface Indicator Tiles TW1-XX by Tarkett Johnsonite, colours as selected by Consultant.

## 2.3 ADHESIVES

- .1 Adhesive for Vinyl Composition Tile: Water-based / latex resin adhesive, Clear colour; eg. S-515 Tile Strong Adhesive by Armstrong World Industries.
- .2 Adhesive for Luxury Vinyl Tile: Epoxy adhesive, solvent free; eg. AD-535 by American Biltrite Flooring.
- .3 Adhesive for Rubber Tile and Tactile Walking Surface Indicator Tile: Two-part polyurethane adhesive, solvent free; eg. 975 Two-Part Urethane Adhesive by Tarkett Johnsonite.

## 2.4 ACCESSORIES

- .1 Underlayment: Self-drying, hydraulic cement-based underlayment, having a trowel-applied consistency; mould- and mildew-resistant; capable of achieving a true feather edge; zero VOC content; eg. Feather Finish by Ardex Americas.
- .2 Primers: Acrylic, waterproof type; as recommended by flooring manufacturer.
- .3 Sealers and Wax: As recommended by flooring manufacturer.

## 3 Execution

### 3.1 EXAMINATION

- .1 Refer to Section 01 71 00.
- .2 Verify surfaces are dry, true, even and smooth, and free of gaps, holes, depressions, paint, grease and oil.
- .3 Verify concrete slabs have cured for minimum 28 days.
- .4 Verify concrete slabs have a pH level between 7 and 10.
- .5 Conduct moisture vapour emission rate tests on concrete slabs-on-fill to ASTM F1869. Do not proceed with installation until tests indicate the following:
  - .1 Vinyl Composition Tile and Rubber Tile Flooring: MVER  $\leq$  3.17 kg per 100 m<sup>2</sup> for a 24 hour period.
  - .2 Luxury Vinyl Tile: MVER  $\leq$  2.26 kg per 100 m<sup>2</sup> for a 24 hour period.
- .6 Conduct relative humidity tests on concrete slabs to ASTM F2170. Do not proceed with flooring installation until tests indicate RH  $\leq$  75 percent.
- .7 Determine absorptive nature of substrates by conducting porosity tests to ASTM F3191.

### 3.2 PREPARATION

- .1 Prepare substrate as recommended by manufacturer for absorptive conditions determined by porosity test. Conform to ASTM F710.
- .2 Clean substrate to remove deleterious matter that would impair subsequent installation.
- .3 Prepare substrate as follows:
  - .1 Remove ridges and bumps.
  - .2 Fill low spots, cracks, joints, holes, and other defects.
  - .3 Apply, trowel and float underlayment to leave a smooth, flat, and hard surface.
  - .4 Prohibit traffic until underlayment is cured.
  - .5 Vacuum clean substrate.
- .4 Prime substrates to ensure proper adhesion of Products.

### 3.3 INSTALLATION

- .1 Install Products with joints and seams parallel to building lines to produce symmetrical tile patterns.
- .2 Spread only enough adhesive to permit installation of Products before initial set.
- .3 Set Products in place, press with heavy roller to attain full adhesion.
- .4 Provide perimeter tile of similar size within any given area.
- .5 Provide tactile walking surface indicator tiles, accent tiles, feature strips and inserts where indicated on Drawings.
- .6 Lay flooring continuously from wall to wall in each area, including beneath casework.
- .7 Where adjacent floor finish is dissimilar, terminate resilient tile flooring at centre line of door openings.
- .8 Provide transition strip along junction of dissimilar flooring materials.
- .9 Scribe flooring to walls, columns, floor outlets, and other appurtenances to produce tight joints.
- .10 Lay out game lines and special graphics in accordance with accepted Shop Drawings.

### 3.4 CLEANING

- .1 Refer to Section 01 74 00.

- .2 Clean, seal, and wax installed Products.

### 3.5 PROTECTION

- .1 Refer to Section 01 76 00.
- .2 Protect completed installation with suitable and durable material or by keeping traffic off floor until Ready-for-Takeover.

END OF SECTION

1 General

1.1 RELATED SECTIONS

- .1 Section 07 21 00 - Thermal Insulation.
- .2 Section 09 21 16 - Gypsum Board Assemblies.
- .3 Section 09 51 23 - Acoustical Tile Ceilings.
- .4 Section 09 54 23 - Linear Metal Ceilings.
- .5 Section 09 84 13.13 - Fixed Sound-Absorptive Cementitious Panels.

1.2 REFERENCES

- .1 ASTM C423-17: Standard Test Method for Sound Absorption and Sound Absorption Coefficients by the Reverberation Room Method.
- .2 ASTM E90-09(2016): Standard Test Method for Laboratory Measurement of Airborne Sound Transmission Loss of Building Partitions and Elements.
- .3 CAN/ULC-S102-2018 (REV1): Standard Method of Test for Surface Burning Characteristics of Building Materials and Assemblies.
- .4 CAN/ULC-S114-2018: Standard Method of Test for Determination of Non-Combustibility in Building Materials.
- .5 CAN/ULC-S129-15 (REV1): Standard Method of Test for Smoulder Resistance of Insulation (Basket Method).
- .6 CAN/ULC-S702.1-14 (R2019): Standard for Mineral Fibre Thermal Insulation for Buildings, Part 1: Material Specification.
- .7 ULC-S702.2-15: Standard for Mineral Fibre Thermal Insulation for Buildings, Part 2: Installation.

1.3 DELIVERY, STORAGE AND HANDLING

- .1 Refer to Section 01 60 00.
- .2 Store Products away from construction activity and sources of ignition.
- .3 Protect Products from damage during handling, installation and at point of installation.

2 Products

2.1 MANUFACTURERS

- .1 Manufacturers of acoustical insulation having Product considered acceptable for use:
  - .1 CertainTeed Canada, Inc.
  - .2 Knauf Insulation.
  - .3 Rockwool.
- .2 Manufacturers of flame-resistant acoustical insulation having Product considered acceptable for use:
  - .1 Johns Manville.

- .2 Rockwool.
- .3 Substitution Procedures: Refer to Section 01 25 00.

## 2.2 MATERIALS

- .1 Acoustical Insulation: To CAN/ULC-S702.1, Type 1 Compliant Mineral Fiber Thermal Insulation, non-rigid, friction fit type, manufactured from glass, rock, or slag fibers; and as follows:
  - .1 Noise Reduction Coefficient (ASTM C423):  $NRC \geq 1.10$  @ 100 mm thick.
  - .2 Facing: Unfaced.
  - .3 Density:  $\geq 38$  kg/m<sup>3</sup>.
  - .4 Combustibility (CAN/ULC-S114): Non-combustible.
  - .5 Thickness: As indicated on Drawings.
  - .6 Manufacturer and Product Name: Rockwool Comfort batt
- .2 Flame-Resistant Acoustical Insulation: To CAN/ULC-S702.1, Type 1; mineral fibre acoustical batts, non-rigid, friction fit type, manufactured from only rock or slag fibers; acceptable for use in fire-rated partitions; and as follows:
  - .1 Noise Reduction Coefficient (ASTM C423):  $NRC \geq 1.10$  @ 100 mm thick.
  - .2 Facing: Unfaced.
  - .3 Density:  $\geq 40$  kg/m<sup>3</sup>.
  - .4 Combustibility (CAN/ULC-S114): Non-combustible.
  - .5 Surface Burning Characteristics (CAN/ULC-S102)
    - .1 Flame Spread Index = 0.
    - .2 Smoke Developed Index = 0.
  - .6 Smoulder Resistance (CAN/ULC-S129): 0.09 percent.
  - .7 Thickness: As indicated on Drawings.
  - .8 Manufacturer and Product Name: eg. Rockwool AFB by Rockwool.
- .3 Mechanical Fasteners: Stainless steel screw type fastener, complete with 75 mm OD moulded plastic disc washer.
- .4 Adhesive: Mastic type, synthetic rubber base, fungi resistant, gun or trowel application.

## 3 Execution

### 3.1 INSTALLATION

- .1 Install Products to ULC-S702.2 and ASTM E90, without gaps and voids.
- .2 Fit acoustic insulation tight within spaces, around cut openings, behind and around facility service components within or behind partitions, and tight to items passing through partitions.

### 3.2 PROTECTION

- .1 Refer to Section 01 76 00.
- .2 Protect acoustic insulation at end of each Working Day.
- .3 Protect acoustic insulation in areas where welding will be carried out.
- .4 Replace acoustic insulation damaged by others.
- .5 Protect acoustic insulation requiring a thermal barrier in accordance with authorities

having jurisdiction.

END OF SECTION

1 General

1.1 PRODUCTS FURNISHED OR INSTALLED UNDER OTHER SECTIONS

- .1 Carefully examine the scope of the Work as indicated on Drawings, and include all finishing, whether specifically mentioned or not, except as specifically excluded below:
  - .1 Section 04 21 00 - Clay Unit Masonry: Integral colour.
  - .2 Section 04 22 00 - Concrete Unit Masonry: Integral colour of decorative concrete masonry units.
  - .3 Section 05 10 00 - Structural Metal Framing: Shop priming.
  - .4 Section 05 30 00 - Metal Decking: Galvanized coating.
  - .5 Section 05 50 00 - Metal Fabrications: Shop priming.
  - .6 Section 06 24 00 - High Pressure Decorative Laminate: Integral colour.
  - .7 Section 06 40 00 - Architectural Woodwork: Shop finishing.
  - .8 Section 07 24 23 - Direct-Applied Finish Systems: Integral colour.
  - .9 Section 07 42 13 - Metal Wall Panels: Shop finishing.
  - .10 Section 07 62 00 - Sheet Metal Flashing and Trim: Shop finishing.
  - .11 Section 07 84 00 - Firestopping: Integral colour.
  - .12 Section 07 92 00 - Joint Sealants: Integral colour.
  - .13 Section 08 12 13 - Hollow Metal Frames: Galvannealed coating.
  - .14 Section 08 13 13 - Hollow Metal Doors: Galvannealed coating.
  - .15 Section 08 14 00 - Wood Doors: Shop finishing.
  - .16 Section 08 31 00 - Access Doors and Panels: Shop priming.
  - .17 Section 08 41 13 - Aluminum-Framed Entrances and Storefronts: Anodized coating.
  - .18 Section 08 44 13 - Glazed Aluminum Curtain Wall: Anodized coating.
  - .19 Section 08 51 13 - Aluminum Windows: Anodized coating.
  - .20 Section 08 71 00 - Door Hardware: Shop finishing.
  - .21 Section 08 90 00 - Louvers and Vents: Anodized coating and shop finishing.
  - .22 Section 09 51 23 - Acoustical Tile Ceilings: Shop finishing.
  - .23 Section 10 14 00 - Signage: Shop finishing.
  - .24 Section 10 14 53 - Traffic Signage: Shop finishing.
  - .25 Section 10 28 13 - Toilet Accessories: Shop finishing.
  - .26 Section 12 24 13.16 - Manual Roller Window Shades: Anodized coating.
  - .27 Do not paint glass surfaces.
  - .28 Do not paint plastic components.
  - .29 Do not paint plated, polished or anodized metal components.
  - .30 Do not paint stainless steel components.

1.2 RELATED SECTIONS

- .1 Section 03 30 00 - Cast-in-Place Concrete.
- .2 Section 04 22 00 - Concrete Unit Masonry.
- .3 Section 05 10 00 - Structural Metal Framing.
- .4 Section 05 30 00 - Metal Decking.
- .5 Section 05 50 00 - Metal Fabrications.
- .6 Section 06 10 00 - Rough Carpentry.
- .7 Section 06 20 00 - Finish Carpentry.
- .8 Section 07 72 33 - Roof Hatches.
- .9 Section 08 12 13 - Hollow Metal Frames.

- .10 Section 08 13 13 - Hollow Metal Doors.
- .11 Section 08 31 00 - Access Doors and Panels.
- .12 Section 09 21 16 - Gypsum Board Assemblies.
- .13 Section 09 84 13.13 - Fixed Sound-Absorptive Cementitious Panels.
- .14 Section 20 05 53 - Identification of Mechanical Services.
- 1.3 REFERENCES
  - .1 MPI Architectural Painting Specification Manual.
  - .2 SSPC Painting Manual, Volume 2 - Systems and Specifications.
- 1.4 SCHEDULING
  - .1 Schedule painting operations to prevent disruption to the Work.
  - .2 Schedule site finishing of doors and frames prior to door, glass and hardware installation.
- 1.5 PRODUCT DATA
  - .1 Submit Product data as specified in Section 01 33 00.
  - .2 Product Data: Manufacturers' standard data sheets for each finishing Product being used, indicating relevant MPI finish system, volatile organic compound (VOC) content, and volume solids (VOL SOL) content.
- 1.6 SAMPLES
  - .1 Submit samples as specified in Section 01 33 00.
  - .2 Selection Samples: A full range of colour selector samples for each type of coating required.
  - .3 Verification Samples: If requested by Consultant, prepare 1 000 x 1 000 mm size sample panels. Apply finish to actual substrate material, or an acceptable alternate if required to be portable.
- 1.7 EXTRA STOCK MATERIALS
  - .1 Supply extra stock materials as specified in Section 01 78 00.
  - .2 Extra Stock Materials: Minimum 4 L of each Product, colour and sheen used.
  - .3 Supply extra stock materials in unopened, new containers, clearly labelled as to manufacturer, Product, colour and sheen.
- 1.8 QUALIFICATIONS
  - .1 Applicators: A firm specializing in commercial painting and finishing of buildings in accordance with MPI Architectural Painting Specification Manual, and having minimum 10 years documented experience.
- 1.9 DELIVERY, STORAGE AND HANDLING
  - .1 Refer to Section 01 60 00.
  - .2 Deliver Products in original containers with unbroken seals and labelled to indicate name of manufacturer, brand, colour and quality of contents.



- .3 Store thinners, loose soaked rags and similar combustible materials in closed containers. Remove from Place of the Work or store in an assigned area.
- .4 Provide adequate safe-guards against spontaneous combustion of finishing materials.
- .5 Arrange for a properly enclosed and heated space, satisfactory to Consultant, to be used as a paint shop. Store Products at minimum 10 degrees C.

#### 1.10 AMBIENT CONDITIONS

- .1 Conform to MPI Architectural Painting Specification Manual.
- .2 Apply water-based paints only when temperature of surfaces to be finished and surrounding air temperatures are between 10 degrees C and 30 degrees C.
- .3 Apply solvent-thinned paints only when temperature of surfaces to be finished and surrounding air temperatures are between 6 degrees C and 32 degrees C.
- .4 Do not apply finishes in snow, rain, fog or mist.
- .5 Do not apply finishes when relative humidity exceeds 85 percent RH; or at temperatures less than 2 degrees C above dew point; or to damp or wet surfaces.

#### 1.11 WARRANTY

- .1 Submit extended warranty in accordance with General Conditions of the Contract.
- .2 Extended Warranty: A two year MPI guaranty, or two year 100 percent maintenance bond, covering refinishing of defective Products resulting from faulty workmanship or defective materials.

### 2 Products

#### 2.1 MANUFACTURERS

- .1 Manufacturer: Use only Products from manufacturers listed in MPI Architectural Painting Specification Manual for specified paint and finish system.
- .2 Single-Source Responsibility: Provide primers and undercoats from same manufacturer as finish coats.

#### 2.2 DESCRIPTION

- .1 Gloss Ratings: Paint gloss shall be defined as the sheen rating of applied paint, in accordance with the following gloss level categories, as defined in MPI Architectural Painting Specification Manual:
  - .1 Gloss Level G1: Matte or Flat finish.
  - .2 Gloss Level G2: Velvet finish.
  - .3 Gloss Level G3: Eggshell finish.
  - .4 Gloss Level G4: Satin finish.
  - .5 Gloss Level G5: Semi-Gloss finish.
  - .6 Gloss Level G6: Gloss finish.
- .2 Gloss Level G7: High-Gloss finish. Colours: A maximum of 5 exterior colours and 20 interior colours may be required. There may be more than two colours used in each room or space.

## 2.3 PERFORMANCE CRITERIA

- .1 Volatile Organic Compound Content (VOC): Use only paints and coatings having a volatile organic compound (VOC) content as follows:
  - .1 Gloss Level G1: < 50 g/L.
  - .2 Gloss Levels G2-G7: < 150 g/L.
- .2 Volume Solids Content (VOL SOL): Use only paints and coatings having a volume solids (VOL SOL) content as follows:
  - .1 Alkyd Paints and Coatings:  $\geq$  45 percent.
  - .2 Latex Paints and Coatings:  $\geq$  40 percent.

## 2.4 MATERIALS

- .1 Paints and Coatings: Use only Products meeting specified performance criteria and listed in most current Approved Products List included in MPI Architectural Painting Specification Manual, for each specified paint and finish system.
- .2 Paint Accessory Materials: Linseed oil, shellac, turpentine, and other materials of commercial quality.

## 2.5 MIXING

- .1 Pigments shall be fully ground and shall maintain a soft paste consistency in the vehicle during storage, that can and will be dispersed readily and uniformly by paddle to a complete, homogeneous mixture.
- .2 Carefully mix and prepare paint materials according to manufacturer's directions.
- .3 Maintain containers used in mixing and applying paint in a clean condition, free of foreign materials and residue.
- .4 Stir material before application to produce a mixture of uniform density. Do not stir surface film into material. Remove film and, if necessary, strain material before using.
- .5 Use only thinners approved by paint manufacturer, and only within recommended limits.
- .6 Tint each undercoat a lighter shade to facilitate identification of each coat where multiple coats of same material are applied. Tint undercoats to match colour of finish coat, but provide sufficient differences in shade of undercoats to distinguish each separate coat.

## 3 Execution

### 3.1 EXAMINATION

- .1 Refer to Section 01 71 00.
- .2 Measure moisture content of surfaces using an electronic moisture metre. Do not apply finishes unless moisture content of surfaces are below recommended maximum values.

### 3.2 PREPARATION

- .1 Prepare surfaces to MPI Architectural Painting Specification Manual.
- .2 Mask out surrounding surfaces not to receive paint, to protect from overspray or overbrushing.

- .3 Remove hardware and accessories, plates, machined surfaces, lighting fixtures and similar items already installed but not intended to be painted.
- .4 Remove mildew, efflorescence and foreign materials from surfaces using appropriate methods.
- .5 Correct minor defects and deficiencies in surfaces which affect application of paints and coatings.
- .6 Clean and prepare surfaces to be painted according to manufacturers' instructions for each particular substrate condition and finish system.
- .7 Provide barrier coats over incompatible primers.
- .8 Clean ungalvanized ferrous metal surfaces designated to receive site finish. Use solvent or mechanical cleaning methods to SSPC Painting Manual, Volume 2 - Systems and Specifications.
- .9 Clean galvanized surfaces with non-petroleum-based solvents. Surface to be free of oil and surface contaminants. Remove pretreatment from galvanized steel metal fabricated from coil stock by mechanical methods.

### 3.3 APPLICATION

- .1 Apply Products to MPI Architectural Painting Specification Manual.
- .2 Protect adjacent surfaces and areas, including equipment, labels and signage from damage during painting operations. Use drop cloths, shields, masking, templates or other suitable protective means.
- .3 Make Good damage caused by failure to protect surfaces.
- .4 Erect barriers or screens and post signs to warn of or limit or direct traffic away or around work areas as required.
- .5 Use methods best suited for substrate and type of material being applied.
- .6 Do not use compressed air or aerosol methods of application without prior written approval of Consultant.
- .7 Spread finishes evenly and flow on smoothly without runs or sags.
- .8 Apply Products no thinner than manufacturer's recommended spreading rate. Provide total dry film thickness of entire system as recommended by manufacturer.
- .9 Apply Products under adequate illumination.
- .10 Sand lightly between coats to achieve required finish.
- .11 Where clear finishes are required, tint fillers to match wood. Work fillers into grain before set. Wipe excess from surface.
- .12 Back prime interior wood work with enamel primer sealer paint.
- .13 Back prime exterior wood work with exterior primer paint.
- .14 Pigmented (Opaque) Finishes: Completely cover substrate to a smooth, opaque surface of uniform finish, colour, appearance, and coverage. Cloudiness, spotting, holidays, laps, brush marks, runs, sags, ropiness, or other surface imperfections will not be accepted.

- .15 Transparent (Clear) Finishes: Use multiple coats to produce a glass-smooth surface film of even luster. Provide a finish free of laps, cloudiness, colour irregularity, runs, brush marks, orange peel, nail holes or other surface imperfections.
- .16 Match approved samples for colour, texture, and coverage. Remove, refinish or repaint work not complying with specified requirements.

#### 3.4 FACILITY SERVICES

- .1 Unless otherwise specified or noted, paint "unfinished" conduits, piping, hangers, ductwork and other mechanical and electrical equipment with colour and texture to match adjacent surfaces, in the following areas:
  - .1 Where exposed-to-view in exterior and interior areas.
  - .2 In high humidity interior areas.
  - .3 In mechanical and electrical rooms.
- .2 Remove finished louvres, grilles, covers, and access panels on facility service components from location and paint separately. Finish paint primed equipment to colour selected by Consultant.
- .3 Paint inside of air ducts, convection and baseboard heating cabinets where visible behind louvers, grilles and diffusers for minimum 460 mm or beyond sight line, whichever is greater with primer and one coat of matt black (non-reflecting) paint.
- .4 Paint inside of light valances gloss white.
- .5 Paint disconnect switches for fire alarm system and exit light systems in red enamel.
- .6 Paint red or band fire protection piping and sprinkler lines as specified in Section 20 05 53. Keep sprinkler heads free of paint.
- .7 Paint yellow or band natural gas piping as specified in Section 20 05 53.
- .8 Backprime and paint face and edges of plywood service panels a semi-gloss, gray colour before installation of telephone and electrical equipment. Leave equipment in original finish except for touch-up as required, and paint conduits, mounting accessories and other unfinished items.
- .9 Paint exterior steel electrical light standards. Do not paint outdoor transformers and substation equipment.
- .10 Colour code equipment, piping, conduit, and exposed ductwork in accordance with colour schedule. Colour band and identify with flow arrows, names, and numbering.
- .11 In unfinished areas, leave exposed conduits, piping, hangers, ductwork and other facility service components in original finish. Touch-up scratches and marks.
- .12 Touch-up scratches and marks on factory painted finishes and equipment with paint as supplied by equipment manufacturer.
- .13 Do not paint over nameplates.

#### 3.5 FIELD QUALITY CONTROL

- .1 Inspect surfaces, preparation and paint applications.
- .2 Painted surfaces shall be considered to lack uniformity and soundness if any of the following defects are apparent:
  - .1 Brush or roller marks, streaks, laps, runs, sags, drips, heavy stippling, hiding or

- shadowing by inefficient application methods, skipped or missed areas, and foreign materials in painted coatings.
  - .2 Evidence of poor coverage at fastener heads, plate edges, lap joints, crevices, pockets, corners and re-entrant angles.
  - .3 Damage due to touching before paint is sufficiently dry or other contributory cause.
  - .4 Damage due to application on moist surfaces or caused by inadequate protection from weather.
  - .5 Damage or contamination of paint due to blown contaminants (dust, spray paint, etc.).
- .3 Painted surfaces will be rejected if any of the following are evident under natural lighting source for exterior surfaces and final lighting source (including daylight) for interior surfaces:
- .1 Visible defects are evident on vertical surfaces when viewed at normal viewing angles from a distance of not less than 1 000 mm.
  - .2 Visible defects are evident on horizontal surfaces when viewed at normal viewing angles from distance of not less than 1 000 mm.
  - .3 Visible defects are evident on ceiling, soffit and other overhead surfaces when viewed at normal viewing angles.
  - .4 When final coat on any surface exhibits a lack of uniformity of colour, sheen, texture and hiding across full surface area.
- .4 Make Good rejected surfaces. Small affected areas may be touched up; large affected areas or areas without sufficient dry film thickness of paint shall be repainted. Runs, sags or damaged paint shall be removed by scraper or by sanding prior to application of paint.
- 3.6 ADJUSTING
- .1 Following completion of painting and finishing operations, reinstall removed items.
  - .2 Remove protective covers and masking from protected surfaces.
  - .3 Repaint damaged surfaces to satisfaction of Consultant.
- 3.7 CLEANING
- .1 Refer to Section 01 74 00.
  - .2 Remove paint where spilled, splashed, splattered or sprayed using means and materials that are not detrimental to affected surfaces.
  - .3 Keep work area free from unnecessary accumulation of tools, equipment, surplus materials and debris.
  - .4 Remove combustible rubbish materials and empty paint cans each day and safely dispose of same in accordance with authorities having jurisdiction.
  - .5 Clean equipment and dispose of wash water / solvents as well as other cleaning and protective materials, paints, thinners, paint removers and strippers in accordance with authorities having jurisdiction.
  - .6 Leave the Work clean and free from dirt and debris.
- 3.8 WASTE MANAGEMENT
- .1 Paint, stain and wood preservative finishes and related materials (thinner, solvents, etc.) are regarded as hazardous products and are subject to regulations for disposal. Obtain information on these controls from authorities having jurisdiction.

- .2 Separate and recycle waste materials. Where paint recycling is available, collect waste paint by type and deliver to recycling or collection facility. Materials that cannot be reused must be treated as hazardous waste and disposed of in an appropriate manner.
- .3 Place materials defined as hazardous or toxic waste, including used sealant and adhesive tubes and containers, in containers or areas designated for hazardous waste.
- .4 To reduce the amount of contaminants entering waterways, sanitary sewers, storm sewers, or into the ground strictly adhere to the following procedures:
  - .1 Retain cleaning water for water-based materials to allow sediments to be filtered out. Do not clean equipment using free draining water.
  - .2 Retain cleaners, thinners, solvents and excess paint and place in designated containers and ensure proper disposal.
  - .3 Return solvent and oil soaked rags used during painting operations for contaminant recovery, proper disposal, or appropriate cleaning and laundering.
  - .4 Dispose of contaminants in an approved legal manner in accordance with applicable regulatory requirements dealing with hazardous waste.
  - .5 Empty paint cans are to be dry prior to disposal or recycling.
  - .6 Close and tightly seal partly used cans of materials, including sealant and adhesive containers and store protected in well ventilated fire-safe area at moderate temperature.
- .5 Set aside and protect surplus and uncontaminated finish materials not required by Owner and deliver or arrange collection of verifiable re-use or re-manufacturing.

### 3.9 PROTECTION

- .1 Refer to Section 01 76 00.
- .2 Protect other surfaces from paint or damage.
- .3 Repair damage.

### 3.10 FINISH SCHEDULE

- .1 Provide the following paint or finish systems for the various substrates indicated, in accordance with MPI Architectural Painting Specification Manual.
- .2 Exterior Painting and Finishing Schedule
  - .1 Structural Steel
    - .1 Corrosion-Resistant Opaque Painted Finish: EXT. 5.1B - W.B. LIGHT INDUSTRIAL COATING (over inorganic zinc), Premium Grade; Gloss Level G5.
  - .2 Metal Fabrications
    - .1 Opaque Painted Finish: EXT. 5.1D - ALKYD (over alkyd metal primer), Premium Grade; Gloss Level G5.
  - .3 Galvanized and Galvannealed Metal
    - .1 Opaque Painted Finish: EXT. 5.3B - ALKYD (over cementitious primer), Premium Grade; Gloss Level G6.
  - .4 Aluminum (Not Anodized)
    - .1 Opaque Painted Finish: EXT. 5.4H - LATEX (over q.d. metal primer), Premium Grade, Gloss Level G6.

- .5 Dimension Lumber and Panels
  - .1 Opaque Painted Finish: EXT. 6.2A - LATEX (over alkyd/oil primer), Premium Grade; Gloss Level G5.
  - .2 Opaque Stained Finish: EXT. 6.2B - SOLID COLOR STAIN, W.B. (over alkyd/oil primer), Premium Grade; Gloss Level G1.
  - .3 Semi-Transparent Stained Finish: EXT. 6.2E - VARNISH, S.B. (over s.b. stain), Premium Grade; Gloss Level G5.
- .6 Dressed Lumber and Panels
  - .1 Opaque Painted Finish: EXT. 6.3A - LATEX (over alkyd/oil primer), Premium Grade; Gloss Level G5.
  - .2 Semi-Transparent Stained Finish: EXT. 6.3E - VARNISH, S.B. (over s.b. stain), Premium Grade; Gloss Level G5.
  - .3 Opaque Stained Finish: EXT. 6.3K - SOLID COLOR STAIN, W.B. (over alkyd/oil primer), Premium Grade; Gloss Level G1.
- .3 Interior Painting and Finishing Schedule
  - .1 Concrete Surfaces (except floors)
    - .1 Epoxy Finish: INT. 3.1G - EPOXY-MODIFIED LATEX (for smooth concrete), Premium Grade; Gloss Level G6.
    - .2 Opaque Painted Finish: INT. 3.1M - INSTITUTIONAL LOW ODOR / VOC, Premium Grade; Gloss Level G4.
  - .2 Concrete Floors
    - .1 Epoxy Finish: INT. 3.2C - EPOXY, Premium Grade; Gloss Level G5.
  - .3 Sound-Absorptive Cementitious Panels
    - .1 Opaque Painted Finish: INT. 3.3G - INSTITUTIONAL LOW ODOR / VOC, Premium Grade; Gloss Level G3.
  - .4 Concrete Masonry Units
    - .1 Opaque Painted Finish: INT. 4.2E - INSTITUTIONAL LOW ODOR / VOC (over latex block filler), Premium Grade; Gloss Level G4.
    - .2 Epoxy Finish: INT. 4.2J - EPOXY-MODIFIED LATEX (over latex block filler) FOR DRY ENVIRONMENTS, Premium Grade; Gloss Level G6.
  - .5 Structural Steel, Steel Joists, Steel Deck and Metal Fabrications
    - .1 Opaque Painted Finish - Overhead Applications: INT. 5.1C - W.B. DRY FALL (over q. d. alkyd primer), Budget Grade; Gloss Level G5.
    - .2 Opaque Painted Finish: INT. 5.1E - ALKYD (over q.d. alkyd primer), Premium Grade; Gloss Level G5.
    - .3 Epoxy Finish: INT. 5.1K - EPOXY-MODIFIED LATEX (over w.b. rust-inhibitive primer), Premium Grade; Gloss Level G6.
  - .6 Galvanized and Galvannealed Metal
    - .1 Opaque Painted Finish: INT. 5.3N - INSTITUTIONAL LOW ODOR / VOC (over w. b. galvanized primer), Premium Grade; Gloss Level G5.
  - .7 Dimension Lumber and Panels
    - .1 Semi-Transparent Stained Fire-Retardant Finish: INT. 6.2FF - FIRE RETARDANT, PIGMENTED, W.B., Premium Grade; Gloss Level G4.
    - .2 Semi-Transparent Stained Finish: INT. 6.2J - POLYURETHANE VARNISH (over s.b. stain), Premium Grade; Gloss Level G4.
    - .3 Opaque Painted Finish: INT. 6.2L - INSTITUTIONAL LOW ODOR / VOC (over latex primer), Premium Grade; Gloss Level G5.

- .8 Dressed Lumber, Panels and Veneers
  - .1 Semi-Transparent Stained Finish: INT. 6.3EE - POLYURETHANE VARNISH (over w.b. stain), Premium Grade; Gloss Level G4.
  - .2 Semi-Transparent Stained Fire-Retardant Finish: INT. 6.3RR - FIRE RETARDANT, PIGMENTED, W.B., Gloss Level G4.
  - .3 Opaque Painted Finish: INT. 6.3V - INSTITUTIONAL LOW ODOR / VOC (over latex primer), Premium Grade; Gloss Level G5.
- .9 Gypsum Board
  - .1 Epoxy Finish: INT. 9.2F - EPOXY-MODIFIED LATEX (over latex primer/sealer), Premium Grade; Gloss Level G6.
  - .2 Opaque Painted Finish: INT. 9.2M - INSTITUTIONAL LOW ODOR / VOC (over latex primer/sealer), Premium Grade; Gloss Levels as follows:
    - .1 Ceiling Applications: G1.
    - .2 All Other Applications: G3.

END OF SECTION



1 General

1.1 RELATED SECTIONS

- .1 Section 04 22 00 - Concrete Unit Masonry.
- .2 Section 06 20 00 - Finish Carpentry.
- .3 Section 06 40 00 - Architectural Woodwork.
- .4 Section 09 21 16 - Gypsum Board Assemblies.

1.2 REFERENCES

- .1 AAMA 611-14: Voluntary Specification for Anodized Architectural Aluminum.
- .2 ANSI A208.1-2009: Particleboard.
- .3 ASTM A424/A424M-18: Standard Specification for Steel, Sheet, for Porcelain Enameling.
- .4 ASTM A653/A653M-20: Standard Specification for Steel Sheet, Zinc-Coated (Galvanized) or Zinc-Iron Alloy-Coated (Galvannealed) by the Hot-Dip Process.
- .5 ASTM B221M-21: Standard Specification for Aluminum and Aluminum-Alloy Extruded Bars, Rods, Wire, Profiles, and Tubes (Metric).
- .6 PEI 1002: Manual and Performance Specifications for Porcelain Enamel Writing Surfaces.
- .7 CAN/ULC-S102-2018 (REV1): Standard Method of Test for Surface Burning Characteristics of Building Materials and Assemblies.
- .8 CAN/ULC-S706.1-2020: Standard for Wood Fibre Insulating Boards for Buildings.

1.3 SHOP DRAWINGS

- .1 Submit Shop Drawings as specified in Section 01 33 00.
- .2 Shop Drawings: Project-specific drawings, illustrating materials, layouts, component dimensions and thicknesses, details of connections and fastening, trim, and hardware, and shop-applied finishes.

1.4 CLOSE-OUT SUBMITTALS

- .1 Submit closeout submittals as specified in Section 01 78 00.
- .2 Maintenance Data: Manufacturer's standard maintenance and cleaning guidelines; sufficient quantity for inclusion in the operation and maintenance manuals.
- .3 Additionally, apply removable maintenance instruction labels to each markerboard.

1.5 MOCK-UPS

- .1 Construct mock-ups as specified in Section 01 40 00.
- .2 Mock-Up Panel: A 1 000 x 1 000 mm size mock-up panel; comprised of a markerboard and tackboard; demonstrating the quality of each material, trim pieces, and the method of joining adjacent panels.
- .3 Accepted mock-ups will be used as the standard for acceptance of the Work.
- .4 Remove and replace installed Product that does not conform to accepted mock-up.
- .5 Remove mock-ups from Place of the Work upon Ready-for-Takeover.

## 1.6 WARRANTY

- .1 Submit extended warranty in accordance with General Conditions of the Contract.
- .2 Manufacturer's Extended Warranty: Warrant markerboards for a period of 10 years against defects other than those due to normal usage and wear, including fading, crazing, chipping, peeling, and the surface becoming slick, glassy or otherwise unsuitable for use.

## 2 Products

### 2.1 MANUFACTURERS

- .1 Manufacturers having Product considered acceptable for use:
  - .1 ASI Visual Display Products, Inc.
  - .2 Claridge.
  - .3 Delta Products, Ltd.
  - .4 Global School Products Inc.
  - .5 Martack Specialties Ltd.
- .2 Substitution Procedures: Refer to Section 01 25 00.

### 2.2 DESCRIPTION

- .1 Use only matching components from a single manufacturer's series of Products.

### 2.3 REGULATORY REQUIREMENTS

- .1 Test Products for surface burning characteristics to CAN/ULC-S102.

### 2.4 MATERIALS

- .1 Extruded Aluminum: To ASTM B221M, 6063 alloy, T5 temper.
- .2 Porcelain Enameled Sheet Steel: To ASTM A424/A424M, Type I, Commercial Steel.
- .3 Sheet Steel: To ASTM A653/A653M, Commercial Steel (CS), Types A, B, and C; galvanized.
- .4 Cork: Natural cork, Tan colour.
- .5 Fibreboard: To CAN/ULC-S706.1, Type I; impregnated, sound absorbing type.
- .6 Particleboard: To ANSI A208.1, Grade M-2.

### 2.5 MANUFACTURED UNITS

- .1 Markerboard: Sandwich type construction, as follows:
  - .1 Face Panel: 0.76 mm thick porcelain enameled sheet steel; writable and washable surface, acid-resistant; White colour.
  - .2 Core: 11 mm thick fibreboard.
  - .3 Back-up Balancing Sheet: 0.4 mm thick sheet steel.
  - .4 Markerboard to include 406mm magnetic tray.
- .2 Tackboard: 13 mm thick; factory laminated; as follows:
  - .1 Tackable Surface: 6 mm thick cork.
  - .2 Back-up Panel: 6 mm thick particleboard.
- .3 Aluminum Trim: 1.5 mm thick extruded aluminum profiles; eg. Series 9800 by ASI Visual Display Products, Inc., comprised of:
  - .1 Perimeter and divider trim,
  - .2 Map rail, with integral tan cork insert, end stops and two combination roller map hooks for every 1 830 mm of map rail,

- .3 Concealed mechanical joining system, including 25 mm wide integrally slotted PVC inserts laminated into ends of panels, and 2.0 mm thick galvanized steel splines.
- .4 Marker tray: 406mm long, magnetic.

## 2.6 FABRICATION

- .1 Markerboards: Factory laminate core to face panel and back-up balancing sheet under heat and pressure.
  - .1 Provide permanent music score lines to one markerboard in each Music Room.
- .2 Tackboards: Factory laminate tackable surface to back-up panel under mechanical pressure, using a waterproof adhesive.

## 2.7 FINISHES

- .1 Anodized Coating on Extruded Aluminum: To AAMA 611, AA-A41 Clear etched and anodized satin finish, free from extruding draw marks and surface scratches.
- .2 Porcelain Enamel Coating on Sheet Steel: To PEI 1002; having a gloss factor between 6 - 8 when measured with 45 degree glossometer.
- .3 Galvannealed Coating on Sheet Steel: To ASTM A653/A653M, ZF120 wiped zinc-iron alloy coating, with streak-free matte grey appearance.

## 3 Execution

### 3.1 EXAMINATION

- .1 Refer to Section 01 71 00.
- .2 Verify millwork units designated to incorporate visual display surfaces are installed.

### 3.2 INSTALLATION

- .1 Install components to ensure a rigid, straight, square, plumb installation with horizontal lines level.
- .2 Securely attach aluminum trims to ensure that fastenings are concealed.
- .3 Adhere tackboards to wall surface with an approved adhesive in egg-size blobs at approximately 200 mm OC. Press tackboards firmly into adhesive, ensuring proper adhesion.
- .4 Join markerboards together using concealed mechanical joining system to ensure a flush butted joint, with a hairline appearance.

### 3.3 ADJUSTING

- .1 Leave visual display boards in a state suitable for immediate use by Owner.

### 3.4 CLEANING

- .1 Refer to Section 01 74 00.
- .2 Clean down, remove dirt and leave elements in a first class condition.

END OF SECTION

1. **GENERAL**

1.1 **DESCRIPTION**

1.1.1 The work described in this section consists of the supply and installation and placement of WASHROOM ACCESSORIES.

1.2 **RELATED WORK SPECIFIED ELSEWHERE**

Finish Carpentry under Section 06200  
Painting under Section 09900  
Electrical under Div. 16

1.3 **SHOP DRAWINGS / SUBMITTALS**

1.3.1 Provide shop drawings and product sheets for each item to be installed, include installation drawings and details. The General Contractor shall submit complete shop drawings in sufficient time to allow Architect to review placement with Owner and propose alternate placement without disruption of Work schedule and / or added cost to Owner for additional blocking etc. All work shall be set out from approved shop drawings.

1.3.2 Indicate correct size and description of components, base material, surface finish inside and out, hardware and locks, attachment devices, description of rough-in framing and building-in details of anchors, etc. required for installation.

1.3.3 Provide plan and elevations indicating the proposed location, clearances and mounting heights for all items.

1.3.4 Provide 3 copies of operation and maintenance data for each item of washroom accessories for incorporation into the Project Manuals specified under Section 01300 Administrative Submittals by General Contractor.

1.3.5 Provide special tools and keys required for accessing, assembly/disassembly or removal for washroom accessories in duplicate for each item.

1.4 **DELIVERY, STORAGE AND HANDLING**

1.4.1 Deliver manufactured items to the site packed in protective coverings. Supply protective coatings to prevent damage and store in approved areas.

1.4.2 No trademarks or labels will be accepted on exposed finished surfaces.

1.5 **REFERENCES**

1.5.1 ASTM-A167-96: Standard Specification for Stainless and Heat-Resisting Chromium-Nickel Steel Plate, Sheet and Strip  
ASTM-A653 / A653M-97: Standard Specification for Steel Sheet, Zinc-Coated (Galvanized) or Zinc-Iron Alloy-Coated (Galvanealed) by the Hot-Dip Process.  
ASTM-A924 / A924M-96a: Standard Specification for General Requirements for Steel Sheet, Metallic-Coated by the Hot-Dip Process.  
ASTM-B456-97: Standard Specification for Electrodeposited Coatings of Copper Plus Nickel Plus Chromium and Nickel Plus Chromium.  
CAN/CGSB-1.81-M90: Air Drying and Baking Alkyd Primer for Vehicles and Equipment.  
CAN/CGSB-1.88-92: Gloss Alkyd Enamel Air Drying and Baking.

CAN/CGSB-12.5 –M86: Mirrors, Silvered.  
CAN/CGSB-31-GP-107Ma-90: Non-Inhibited Phosphoric Acid Base Metal Conditioner and Rust Remover.  
CAN/CGSB-B651-95: Barrier-Free Design.  
CAN/CGSB-G164-M92: Hot Dip Galvanizing of Irregular Shaped Articles.

## 2. **PRODUCTS**

2.1 As indicated on the drawings.

2.1.1 Provide reinforcing and anchorage for built-in products.

2.1.2 Insulate between dissimilar metals, and metal and masonry, to prevent electrolysis.

## 2.2 **FABRICATION GENERAL**

2.2.1 Fabricate work true to dimension, square and plumb.

2.2.2 Thickness of metals shall be adequate for the various conditions and intended uses.

2.2.3 Finished work shall be free from warping, open seams, weld marks, rattles, and other defects. Drilling shall be reamed and exposed edges finished smooth. There shall be no sharp edges.

2.2.4 Fastenings shall be concealed or theft-proof type where possible. Exposed fastenings shall be neatly executed and shall be of the same material, texture, colour and finish as the base metal on which they occur. Keep exposed fastenings to absolute minimum, evenly spaced and neatly laid out. Make fastenings of permanent type unless otherwise indicated.

2.2.5 Supply all fasteners, anchors, accessories required for fabrication and erection of work of this Section. Such items occurring on or in an exterior wall or slab shall be hot dip galvanized. Make thread dimensions such that nuts and bolts will fit without rethreading or chasing threads.

2.2.6 Manufactured items shall be shop fabricated according to the best shop practice and shall be finished with a paint prime coat or baked enamel finish according to manufacturer's literature unless stated otherwise herein.

2.2.7 Fit and assemble work in shop where possible. Execute work according to details and approved shop drawings. Where shop fabrication is not possible, make trial assembly in shop.

2.2.8 Do all welding in accordance with requirements of CSA W59. File or grind welds smooth and flush where exposed to view and where specifically indicated on drawings.

2.2.9 Fit joints and intersecting members accurately. Make work in true planes with adequate fastening.

2.2.10 Shop Painting: Where other types of finishing or priming are not specified, thoroughly clean ferrous metals in accordance with SSPC-SP5-63 and apply one coat of primer to CGSB 1-GP-40M. Brush on thoroughly and work well into crevices and interstices.

## 2.3 **WASHROOM ACCESSORIES**

2.3.1 Washroom accessories of the same materials, construction and finishes, similar in function, design, appearance and conforming to the standards of those specified, provide all the equipment from one

manufacturer only, manufactured by the following are considered equal, subject to the approval of the Board:

Bobrick Washroom Equipment of Canada Ltd.  
Bradley Washfountain Co.  
Frost Metal Products Ltd.  
Twin-Cee Ltd.  
Watrous Sales Inc.

2.3.2 General Materials:

- a) Sheet Steel: commercial quality to ASTM-A653/A653M with ZF75 designation zinc coating to ASTM-A924/A924M.
- b) Stainless Steel Sheet Metal: to ASTM-A167, Type 304, with satin finish.
- c) Stainless Steel Tubing: Type 304, commercial grade, seamless welded, 1.2 mm wall thickness, satin finish.
- d) Fasteners: concealed screws and bolts hot dip galvanized. Exposed fasteners shall match the face finish of the unit. Expansion shields of fibre, lead or rubber at solid walls and toggle bolts at hollow walls with blocking reinforcing as required / recommended by accessory manufacturer for the component and its intended use (maximum vandal resistant mounting).

2.3.3 ACCESSORIES: NEW WASHROOMS AND AS INDICATED

- a) Framed Tilting Mirror: (B-290 Series) B-293 -1836 by Bobrick with one piece roll framed, stainless steel frame 1/4" float glass, mirror guaranteed 15 year, tilted, with vandal proof framed mounting assembly.
- b) Framed Mirror: B-1658 1830 18"x30" (46x76cm) by Bobrick. Stainless steel channel frame with 6mm tempered select float glass.
- c) Washroom Grab Bars by Bobrick, stainless steel 18ga bars with stainless steel 3.17 plate, with 38mm clearance between wall and bar. Surface of all bars peened gripped all attached with stainless steel screws in appropriate stems for concrete block application – concealed fasteners. Sizes and shapes as follow:  
  
**Bobrick B-6898.99** Peened L-shaped bar with both legs 762x762 mm long.  
**Bobrick B-6806.99** Peened x 610mm Straight Grab Bar.  
**Bobrick B-4998.99** Peened Wall-Mounted Swing Up Grab Bar, *no substitutions*.
- d) Toilet Tissue Dispenser: 66TR Tork Bath Tissue Jumbo Roll Dispenser supplied by DDSB and installed by General Contractor.
- e) Sanitary Napkin Disposal: Frost 620 supplied by DDSB and installed by General Contractor.
- f) Feminine Hygiene Napkin Vendor / Dispenser: 615-5 Recessed Double Napkin / Tampon Vendor by Frost Products Ltd. Coverall door is all welded stainless steel construction, 20 gauge type 304 No. 4 brushed finish. Recessed wall box of 20 gauge satin coat galvanized. Dispensing cost to be set to free. Supplied by DDSB and installed by General Contractor.
- g) Surface Mounted Soap Dispenser: 9325W Swish Clean & Green Bulk Foam Dispenser supplied by DDSB and installed by General Contractor.
- h) Coat hooks: Vandal-Resistant Clothes Hook MSA-25 by Gamco Commercial Restroom Accessories. Shall be type-304 stainless steel with satin finish. Faceplate shall be 14-gauge (2mm). To be installed with stainless steel machine screws.

2.3.4 See Electrical Specifications for specification / connection of electric hand dryers, nurse call devices, etc. Locations shown on drawings.

### 3. **EXECUTION**

#### 3.1 **INSTALLATION**

- 3.1.1 Strictly adhere to manufacturer's instructions. Ensure proper backing and anchoring to suit required loading. Obtain Architect's and manufacturer's approvals prior to deviations from manufacturer's procedures. Ensure guarantee conditions are met
- 3.1.2 Confirm EXACT installation locations with Architect before proceeding with the work. Do not install items unless back-up surfaces are adequately reinforced to support the item.
- 3.1.3 Mount items securely with concealed or tamper-proof fastenings. Install as indicated on drawings and to required line and levels. Repair construction voids produced by the work of this section to match existing surfaces. Fastenings shall be non-corrosive type.
- 3.1.4 Build and erect work plumb, true, square, straight, level, planar, flush and accurate to sizes detailed, to reviewed shop drawings, free from distortion or defects detrimental to appearance and performance.
- 3.1.5 Insulate metals where necessary to prevent corrosion due to contact between dissimilar metals and between metals and concrete. Use bituminous paint, butyl tape, building paper or other approved means.
- 3.1.6 Supply adequate instructions, templates, and, if necessary, supervise installation of fastenings, accessories, components, etc, required to be built in by Other Contractors and/or Subcontractors.
- 3.1.7 Provide mounting and anchorage devices to be built in to walls and other construction elements as required to securely anchor components in place. Securely anchor components in place. Method of fastening shall ensure that components will be capable of withstanding expected loads without movement.
- 3.1.8 Install framed mirrors with concealed wall hinges and lock in place with theft-proof screws.
- 3.1.9 Strictly adhere to manufacturer's instructions. Ensure guarantee conditions are met. Obtain Owner's and manufacturer's approvals prior to deviations from manufacturer's procedures.
- 3.1.10 Accessories shall comply with all local code requirements for the physically handicapped and installed grab bars shall withstand a minimum push/pull force of 400 lbs. (1.779 KN).

#### 3.2 **CLEANING ADJUSTMENTS**

- 3.2.1 Upon completion of work or when directed, remove all traces of protective coatings or paper.
- 3.2.2 Test mechanisms, hinges, locks, and latches, and where necessary, adjust and lubricate and ensure that accessories are in perfect working order.
- 3.2.3 Remove all sharp edges.

- 3.2.4 After erection and installation, thoroughly clean work and apply field touch-up of same formula as shop coat primer to damaged or unpainted surfaces of shop primed material. Work primer well into joints, crevices, interstices and open spaces.

END OF SECTION