

Design Parameters

Air volume	7,400 ACFM	# of bags in unit	50
Filter area	900 ft²	Volume collected per unit time	4 ft³ / day
Air to Cloth Ratio	8.22	Expected collector usage	8 hrs / day

Equipment Pricing

Model	NFPZ 2HE Filter Unit with (4) 42 Gallon Barrels
Quantity	1
System pressure	Negative
System voltage	575V
Integral fan	(1) NFPZ Top Mount Fan - FM 860 - 25HP - 575V
Integral fan starter or VFD	VFD(s) - (1) 25 HP
Integral fan silencer	FM 800 Silencer w/ Flange (for return air) (1)
Shaker motor cleaning control	Automatic - stop for cleaning every 4 hours
Unit catwalk / gangway	No catwalk / gangway / by others
Doors	Doors w/ locks & explosion panels on top of unit
Sprinkler pipe	Included

Note: Throughout the sales process and installation, the collector location and orientation may change to maintain a safe zone as a precaution for possible explosive events (if applicable) to meet local codes and regulations set by the authority having jurisdiction.

Note: The collector is designed for handling light dust loads and generally collecting less than 50 gallons of dust per 8-hour operation.

Explosion Isolation Flap Valve

Zone 1 EIFV	18" / 450 mm, Flanged, Up to and including ST2	Included
--------------------	--	----------

Additional Equipment

	Spark Detection and Extinguishing System	Included
	Abort Damper 20in	Included
	agnehelic Gauge Kit	Included
	Wind Cross Bracing	Included
	for 42 Gallon Drums	Included

<p>REVIEWED <input checked="" type="checkbox"/> REVIEWED AS NOTED <input type="checkbox"/></p> <p>REVISE & RESUBMIT <input type="checkbox"/> REJECTED <input type="checkbox"/></p> <p>THE INTENTION OF THIS REVIEW IS TO ASCERTAIN CONFORMANCE WITH THE GENERAL DESIGN CONCEPT. IT DOES NOT RELIEVE THE CONTRACTOR AND MANUFACTURER OF RESPONSIBILITY FOR DIMENSIONAL ACCURACY, OMISSIONS, ERRORS AND COMPLIANCE WITH THE CONTRACT DRAWINGS AND DOCUMENTS.</p> <p>BY: <u>C. Pankaj</u> DATE: Mar.9/26</p> <p>COPA ENGINEERING LTD.</p>	<p>ROOT3 ENGINEERING LTD</p> <p>THIS DOCUMENT HAS BEEN REVIEWED BY ROOT3 ENGINEERING LTD FOR GENERAL CONFORMANCE AND DESIGN INTENT. THIS DOES NOT RELEASE THE CONTRACTOR OF RESPONSIBILITY FOR CONFORMANCE WITH THE DESIGN DRAWINGS AND SPECIFICATIONS.</p> <p>REVIEWED <input checked="" type="checkbox"/></p> <p>DATE: Mar 16, 2026 BY: S.H.</p>	<p>ROOT3: REVIEWED FOR ELECTRICAL POWER ONLY.</p>
---	---	---

GS | GACESA SLOTE ARCHITECTS

Reviewed
Reviewed as noted

Revise and resubmit
Not reviewed

Date: 03/17/2026 _____

Reviewed by: gacesa _____

This review by GS | Gacesa Slotte Architects is for the sole purpose of ascertaining conformance with the general design concept for architectural features only and does not in any way constitute review of the design of engineering elements which form part of the contract documents prepared by others. This review shall not mean that GS | Gacesa Slotte Architects approves the detailed design inherent in the shop drawings, responsibility for which shall remain with the Contractor submitting same, and such review shall not relieve the Contractor of his responsibility for errors, or omissions in the shop drawings or of the responsibility for meeting all requirements of the Contract Documents. The Contractor is responsible for dimensions to be confirmed and correlated at the job site, for information that pertains solely to fabrication processes or to techniques of construction and installation and for coordination of the work of all trades.

DUST & MEDIA SPECIFICATIONS
 DUST TYPE: WOOD
 FILTER MEDIA: SUPERBAG XT5
 ANTI-STATIC POLYESTER
 FILTER EFFICIENCY @ 3 MICRON: 99%

NFPZ3000-2HE
VOLTAGE: 575 VAC

SYSTEM SPECIFICATIONS
 50 BAGS WITH TOTAL FILTER AREA: 900 SQ. FT.
 AIR TO CLOTH RATIO @ DESIGN FLOW: 8.22:1
 DESIGN AIRFLOW & PRESSURE: 7400 CFM @ 16" w.c.
 UNPLUGGED FILTER WEIGHT: 2400 LBS
 COMBUSTIBLE DUST RATING: Kst ≤ 200, Pmax ≤ 9bar

1070000207.1

**COLLECTOR
GROUNDING**

- A. STEEL SUPPORT FOR FILTER
- B. FOUNDATION
- C. GROUNDING ROD - COPPER. MIN. DIAMETER: 1/2". MIN. LENGTH 8FT.
- D. CONNECTION 3/8" BOLT & NUT + CABLE LUG
- E. CABLE CONNECTION. SIZE 10 - 3 AWG, HOWEVER, AT LEAST 50% OF LARGEST CONDUCTOR CONNECTED TO THE SYSTEM, BUT MAX. 3 AWG.
- F. CONNECTION BOX FOR EARTHING ROD.

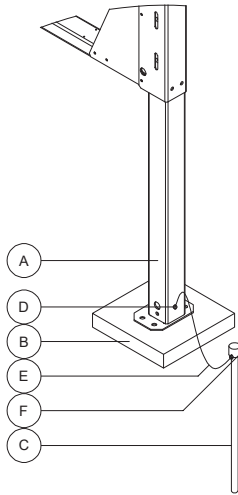

**RESTRICTED AREA
DETAIL**

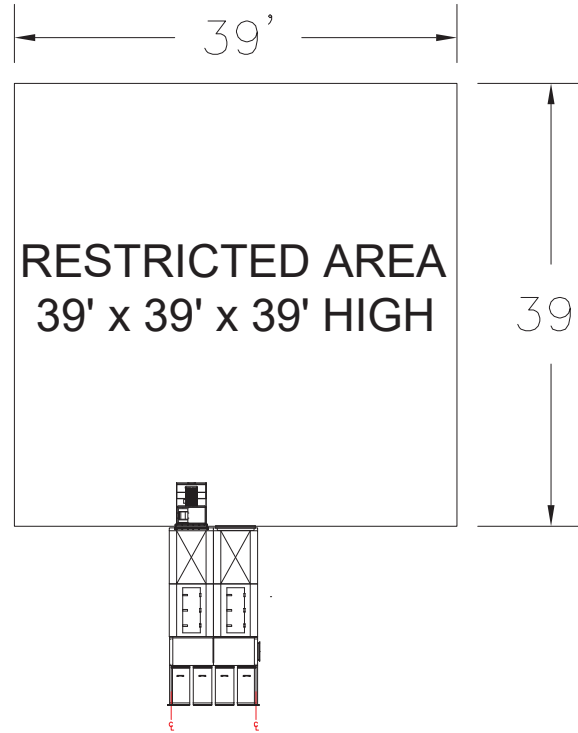

**COLLECTOR
FOOTPLATE
DETAIL**

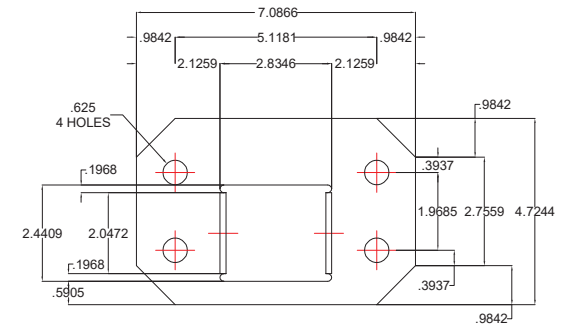

**INLET FLANGE
DETAIL**

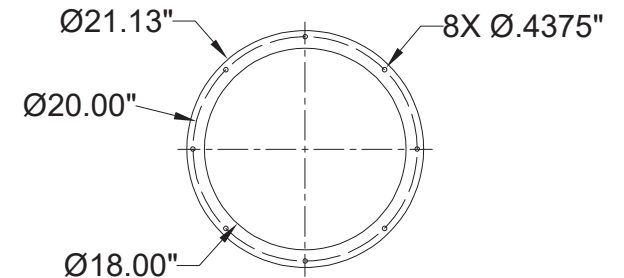

GENERAL NOTES

- THE COLLECTOR AND ROTARY AIR LOCK MUST BE EARTH GROUNDED TO DISSIPATE ANY BUILDUP OF STATIC ELECTRICITY. POWER DIST. PANELS, FEEDERS, AND INDIVIDUAL POWER CIRCUITS TO NEDERMAN MOTOR STARTER TO BE FURNISHED BY CUSTOMER.
- IT IS THE RESPONSIBILITY OF THE CUSTOMER TO ENSURE THAT ALL ADDITIONAL WIRING MEETS N.E.C. AND ALL LOCAL CODES.
- DETERMINATION OF CONCRETE FOOTINGS, PADS, ETC. SIZE, DEPTH, AND MASS TO BE THE RESPONSIBILITY OF THE CUSTOMER BASED ON LOCAL CODES AND INFORMATION SUPPLIED ON THIS DRAWING.
- CONCRETE PAD SHOULD BE SLOPED NO MORE THAN 1/16" OVER 12". ANCHORS FOR FILTER SYSTEM SHOULD NOT BE MADE UNTIL AFTER THE FILTER IS SET AND HOLES MARKED.
- IT IS THE RESPONSIBILITY OF THE CUSTOMER TO PROVIDE PLUMBING AND SPRINKLER FOR FILTER SYSTEM IF REQUIRED.
- DUCTWORK INSTALLATION SHOULD BE PERFORMED TO NEDERMAN DUCTWORK INSTALLATION GUIDELINES
- ANY DEVIATION FROM THE ENGINEERED LAYOUT MAY AFFECT THE PERFORMANCE OF THE DUST COLLECTION SYSTEM. IF YOU MUST DEVIATE FROM THE LAYOUT AS DESIGNED, CONTACT NEDERMAN FOR ENGINEERING APPROVAL.

INCLUDED OPTIONS

- CARZ EXPLOSION ISOLATION DAMPER(S).
- SPARK DETECTION.
- HANSENTEK SYSTEM.
- VARIABLE FREQUENCY DRIVE(S).

EXPLOSION ISOLATION

- CARZ DAMPER MUST BE INSTALLED MINIMUM 18FT MAXIMUM 32FT FROM COLLECTOR INLET.
- NO MORE THAN (2) 90° ELBOWS.

HANSENTEK SYSTEM

- THE EXTINGUISHER MUST BE LOCATED A MIN OF 21' FROM THE DETECTORS AND A MIN OF 5' FROM ANY TRANSITION, ELBOW OR BRANCH.
- THE DETECTORS MUST BE INSTALLED 2.5 DUCT DIAMETERS FROM ANY TRANSITION, ELBOW OR BRANCH.

PROJECT SPECIFIC NOTES:

-

APPROVED FOR CONSTRUCTION

BY: _____

DATE: _____

WITH CORRECTIONS/CHANGES AS NOTED



5865 McLaughlin Road
 Mississauga, ON L5R 1B8
 TEL: +1 855-925-1609
 FAX: +1 905-366-2206

This drawing is confidential and the exclusive property of Nederman, Inc. No unauthorized use/copy or disclosure is to be made and it is to be returned whenever required.

	NAME	DATE	Rev:	Scale:	Title:
DRAWN:	C. SCIDA	22-Jan-26	B		WATERDOWN SECONDARY GENERAL ARRANGEMENT
CHECKED:			Sheet #:	Size:	
			1 of 4	A	

DUST & MEDIA SPECIFICATIONS
 DUST TYPE: WOOD
 FILTER MEDIA: SUPERBAG XT5
 ANTI-STATIC POLYESTER
 FILTER EFFICIENCY @ 3 MICRON: 99%

NFPZ3000-2HE
VOLTAGE: 575 VAC

SYSTEM SPECIFICATIONS
 50 BAGS WITH TOTAL FILTER AREA: 900 SQ. FT.
 AIR TO CLOTH RATIO @ DESIGN FLOW: 8.22:1
 DESIGN AIRFLOW & PRESSURE: 7400 CFM @ 16" w.c.
 UNPLUGGED FILTER WEIGHT: 2400 LBS
 COMBUSTIBLE DUST RATING: Kst ≤ 200, Pmax ≤ 9bar

VIEW TYPE: PLAN

1070000207.1

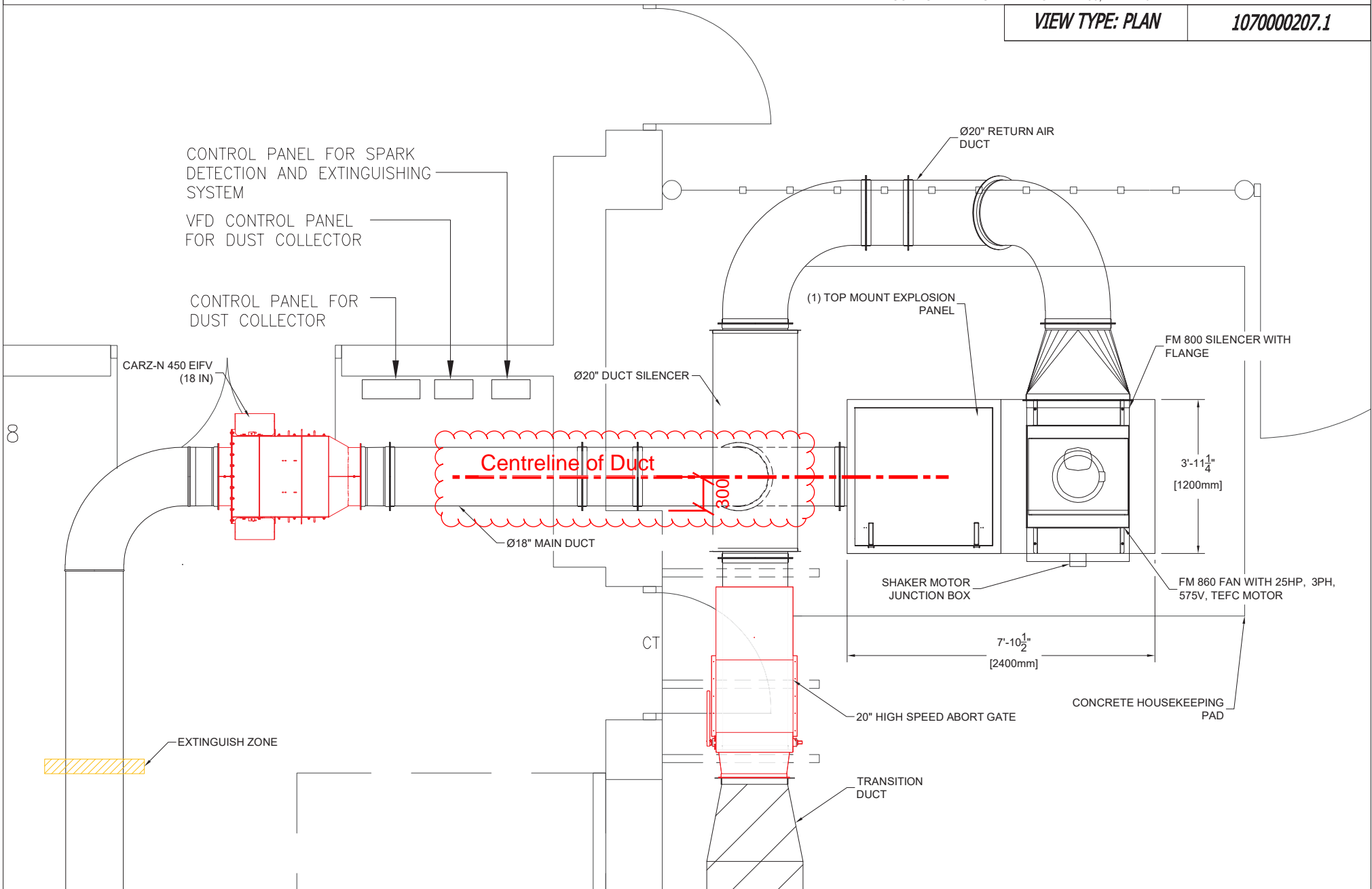

Nederman
 5865 McLaughlin Road
 Mississauga, ON L5R 1B8
 TEL: +1 855-925-1609
 FAX: +1 905-366-2206

This drawing is confidential and the exclusive property of Nederman, Inc. No unauthorized use/copy or disclosure is to be made and it is to be returned whenever required.

	NAME	DATE	Rev:	Scale:	Title:
DRAWN:	C. SCIDA	22-Jan-26	B	1:40	WATERDOWN SECONDARY GENERAL ARRANGEMENT
CHECKED:			Sheet #:	Size:	
			2 of 4	A	

DUST & MEDIA SPECIFICATIONS
 DUST TYPE: WOOD
 FILTER MEDIA: SUPERBAG XT5
 ANTI-STATIC POLYESTER
 FILTER EFFICIENCY @ 3 MICRON: 99%

NFPZ3000-2HE
VOLTAGE: 575 VAC

SYSTEM SPECIFICATIONS
 50 BAGS WITH TOTAL FILTER AREA: 900 SQ. FT.
 AIR TO CLOTH RATIO @ DESIGN FLOW: 8.22:1
 DESIGN AIRFLOW & PRESSURE: 7400 CFM @ 16" w.c.
 UNPLUGGED FILTER WEIGHT: 2400 LBS
 COMBUSTIBLE DUST RATING: Kst ≤ 200, Pmax ≤ 9bar

VIEW TYPE: ELEVATION

1070000207.1

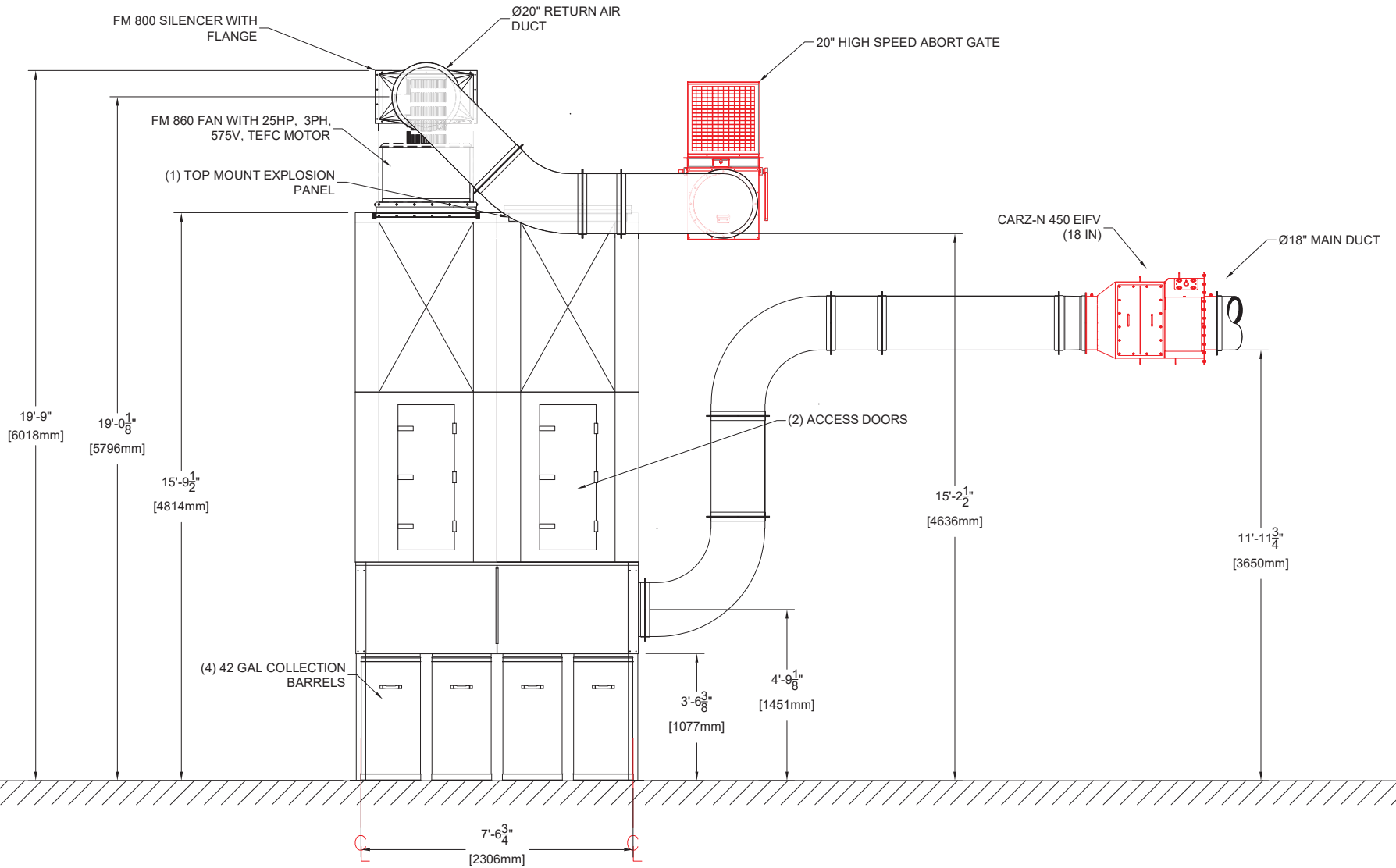

5865 McLaughlin Road
 Mississauga, ON L5R 1B8
 TEL: +1 855-925-1609
 FAX: +1 905-366-2206

This drawing is confidential and the exclusive property of Nederman, Inc. No unauthorized use/copy or disclosure is to be made and it is to be returned whenever required.

	NAME	DATE	Rev:	Scale:	Title:
DRAWN:	C. SCIDA	22-Jan-26	B	1:50	WATERDOWN SECONDARY GENERAL ARRANGEMENT
CHECKED:			Sheet #:	Size:	
			3 of 4	A	

DUST & MEDIA SPECIFICATIONS
 DUST TYPE: WOOD
 FILTER MEDIA: SUPERBAG XT5
 ANTI-STATIC POLYESTER
 FILTER EFFICIENCY @ 3 MICRON: 99%

NFPZ3000-2HE
VOLTAGE: 575 VAC

SYSTEM SPECIFICATIONS
 50 BAGS WITH TOTAL FILTER AREA: 900 SQ. FT.
 AIR TO CLOTH RATIO @ DESIGN FLOW: 8.22:1
 DESIGN AIRFLOW & PRESSURE: 7400 CFM @ 16" w.c.
 UNPLUGGED FILTER WEIGHT: 2400 LBS
 COMBUSTIBLE DUST RATING: Kst ≤ 200, Pmax ≤ 9bar

VIEW TYPE: ELEVATION

1070000207.1

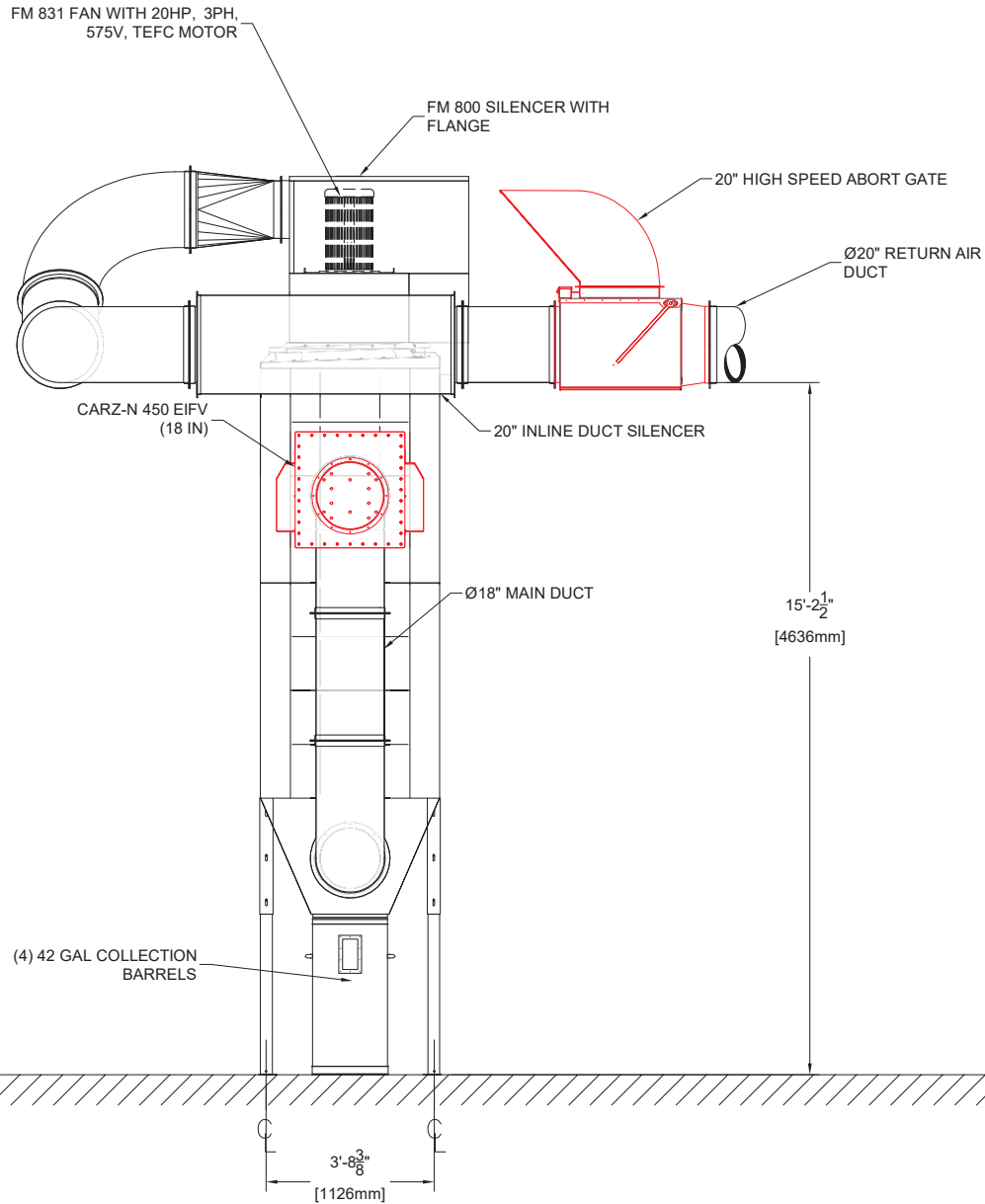

5865 McLaughlin Road
 Mississauga, ON L5R 1B8
 TEL: +1 855-925-1609
 FAX: +1 905-366-2206

This drawing is confidential and the exclusive property of Nederman, Inc. No unauthorized use/copy or disclosure is to be made and it is to be returned whenever required.

	NAME	DATE	Rev:	Scale:	Title:
DRAWN:	C. SCIDA	22-Jan-26	B	1:50	WATERDOWN SECONDARY GENERAL ARRANGEMENT
CHECKED:			Sheet #:	Size:	
			4 of 4	A	

FM Fan and FMZ fan with ATEX declaration

High-efficiency fan for the M-series filter range

FM6XX



FM8XX

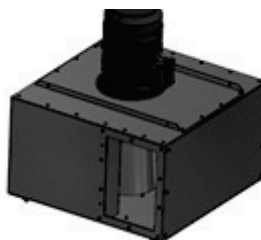

Description

The FM fan range is designed exclusively for direct mounting to the clean air chamber of the MCP and MEP filter units. They are designed for high efficiency with low noise levels and are of the non-over-loading type. This gives a safe and reliable system with minimal power consumption when under reduced loads. The fans are only available in RD version.

The FMZ fan is designed to handle combustible dusts. It is equipped with an inspection door.

Product marking of FMZ fan

For installation in non-zone:

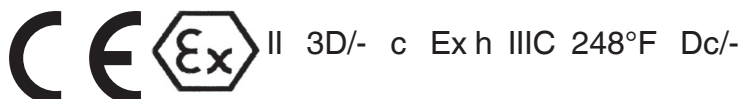

For installation in Zone 22:

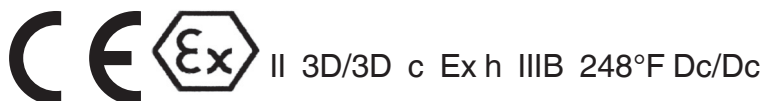

Specification	Standard
Fan, material	Galv. steel, 14 GA
Motor, manufacturer	Standard
Motor, electrical supply	3x230/460 VAC/60Hz 3x575 VAC/60 Hz
Motor and fan speed	3550 RPM
Outlet	Dia. 6 to 24 inches

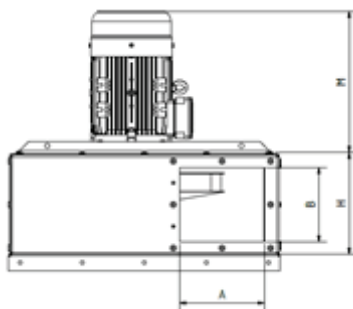
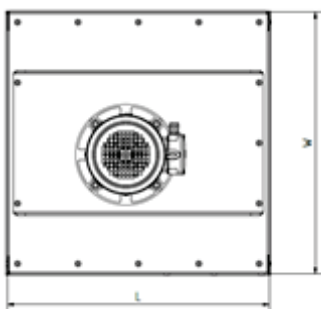

FMZ8XX - fan with inspection

Type	Motor size [HP]	Weight [Lbs]	Optimum duty point [CFM]	Noise level (dB(A-)/1m) ¹	Max. RPM	Efficiency (%)	Max. recomm. air flow [CFM]	Dimensions [inches]					
								L	W	H	M	A	B
FM616	3	170	1100	67	3550	82	1350	25.60	25.60	9.65	13.80	8.10	7.10
FM620	5	185	2000	71	3550	82	2560	25.60	25.60	9.65	13.80	8.10	7.10
FM625	7.5	215	3400	69	3550	82	3980	25.60	25.60	9.65	13.80	8.10	7.10
FM825	10	340	4800	74	3550	80	5590	31.50	31.50	18.30	19.90	10.30	14.95
FM828	15	375	5400	75	3550	82	6350	31.50	31.50	18.30	19.90	10.30	14.95
FM831	20	410	5500	76	3550	82	6700	31.50	31.50	18.30	19.90	10.30	14.95
FM860	25	450	8600	78	3550	80	10960	31.50	31.50	18.30	19.90	10.30	14.95

FM / FMZ FANS
Includes all internal resistance except filter media

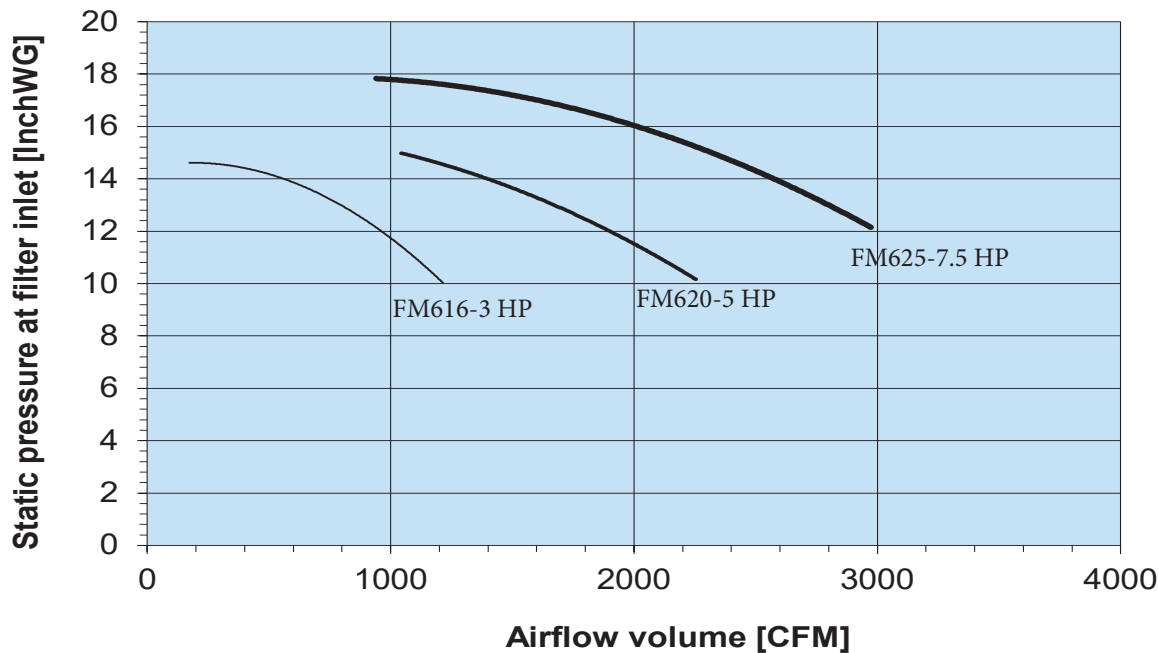

FM / FMZ FANS
Includes all internal resistance except filter media

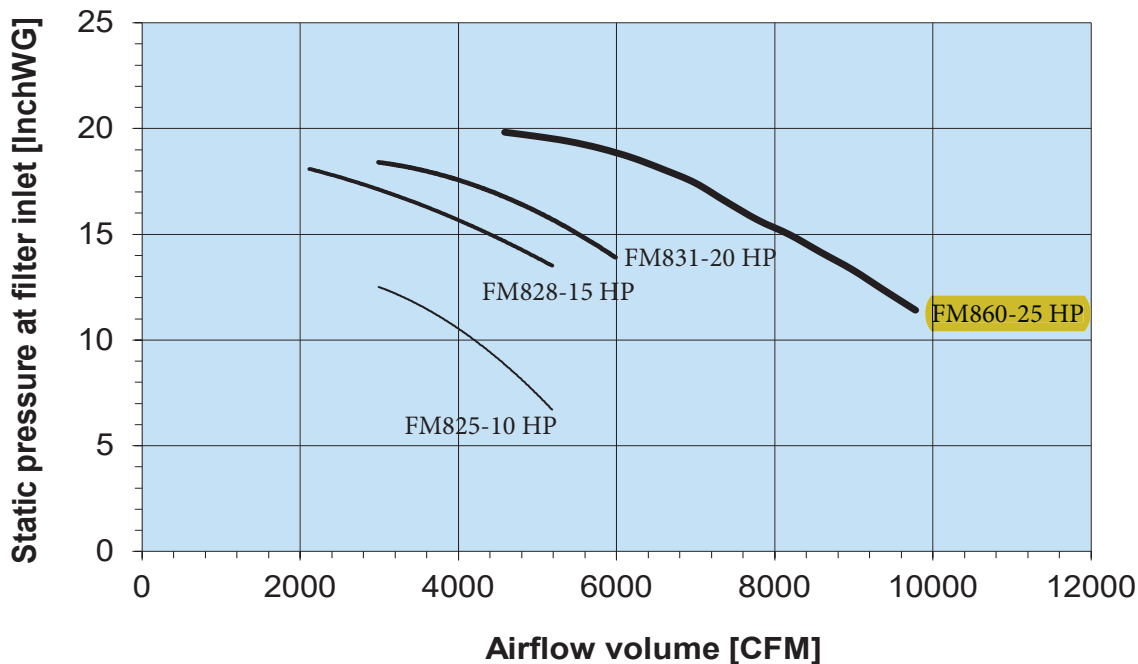

Nederman Variable Frequency Drive - VFD

The Wall Mounted Drives come as a compact and comprehensive drive package, with all the necessary components integrated into a single unit. They are supplied in Type **NEMA 12** enclosures for the power supply voltages specific to the application. **NEMA 12** enclosures are intended mainly for indoor industrial, manufacturing, and machining applications. These metal **enclosures** will protect against dust, dirt, and dripping non-corrosive liquids, oil and lubricants.

The drives are preprogrammed to the application and ready to be installed.



Insight ready

If the control panel supplied with the application is an ***Insight control panel*** only a shielded two conductor wire between the drive and the panel is required to operate the drive and monitor and record critical parameters.

Installation

The drive must be installed in accordance with National Electrical Code and local requirements.

There are no special requirements for clearance side to side, but top and bottom must be clear to allow the cooling air to freely enter and exit the drive. If the drive is placed inside a cabinet proper cooling air flow must be provided in accordance with the direction in the manual for the drive.

Technical data

Table for VFD data and the corresponding frame size. It is important that each VFD will only work in the voltage range specified.

Sizing of branch circuits and fuses must be done based on the Full Load Current (FLC) for the motor load.

525 – 600 VOLT								
Part #	Motor Size [kW]	Motor Size [HP]	Continuous Current IL[A]	Frame size	H in.	W in.	D in.	Weight lbs.
89116296	2.2	3.0	3.9	MR05	16.5	5.7	8.4	22
89116297	4	5.0	6.1					
89116298	5.5	7.5	9					
89116299	7.5	10.0	11					
89116300	11	15.0	18	MR06	21.9	7.7	8.7	44
89116301	15	20.0	22					
89116302	18.5	25.0	27					
89116303	22	30.0	34					
89116304	30	40.0	41	MR07	25.4	9.3	10.2	83
89116305	37	50.0	52					
89116306	45	60.0	62					
89116307	55	75.0	80	MR08	38	11.4	13.5	145.5
89116308	75	100.0	100					
89116309	90	125.0	125					
89116310	110	150.0	144					

DUAL-Silencer for FM fans

DUAL-silencer for enclosure of FM fan motor and the top of the fan case.

The DUAL-silencer encloses the fan motor and the top of the fan case. It may be fitted to any FM unit and take the place of a conventional in-line silencer, with the added benefit of reducing breakout noise from the fan. The DUAL-silencer is available in three sizes, to fit FM600 series, FM800 series fan and the FM1000 fan.

Description

The DUAL-silencer is made of 2mm galvanized steel. The grille may be fitted with a rain cover or replaced by a flanged outlet. These items are interchangeable and are clipped into place on the silencer.

DUAL-Silencer with flanged outlet (for external duct connection)

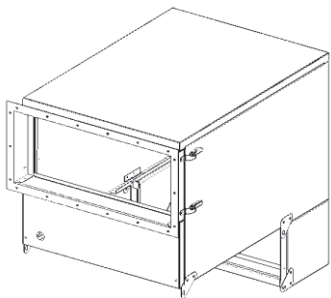

FM800 fan series: 5501833

Type	Max. recommended air flow (m ³ /h)	Typical noise level dB(A), at 1 m from unit, 1 m above floor level (with air grille)
FM800 fan series	9,000	75

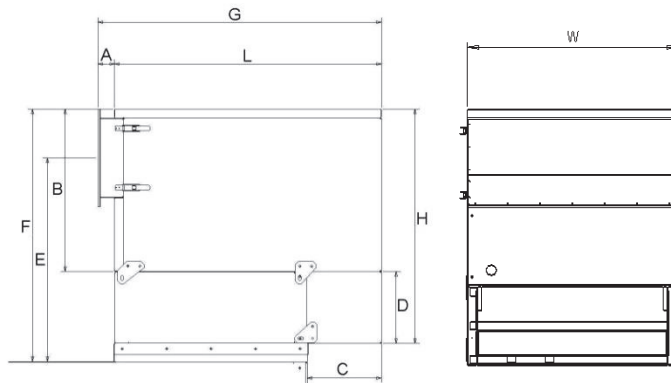

Type	A	B	C	D	E	F	G	H	L	W
FM800 series fans	56	650	400	465	950	1175	1256	1115	1200	800

All dimensions in mm

Flanges

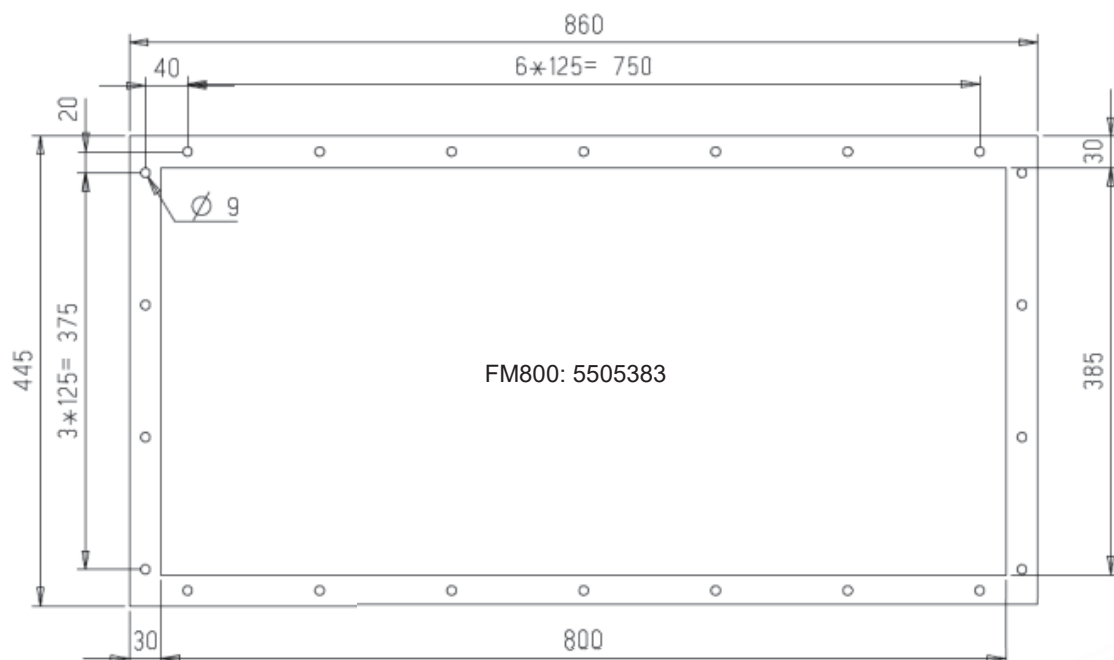

FM800: 5505383

All dimensions in mm

FM DUAL-Silencer

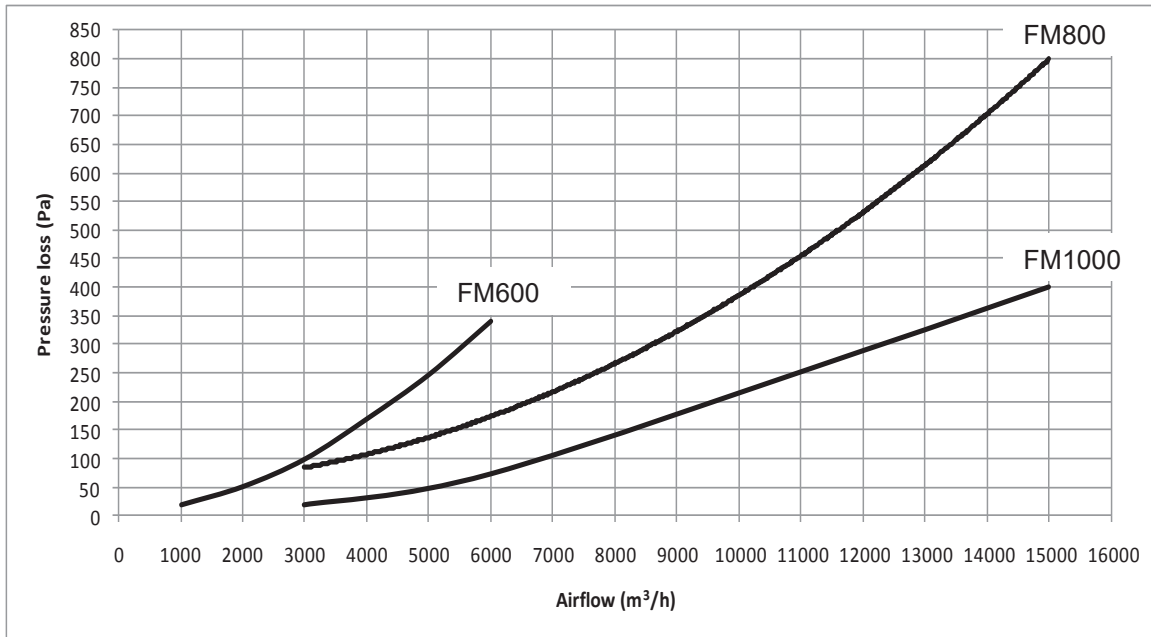

The curves indicate typical pressure drop across the silencers at different airflow volumes.

NFPZ-2 AUTOMATIC SHAKER CLEANING CONTROL PANEL

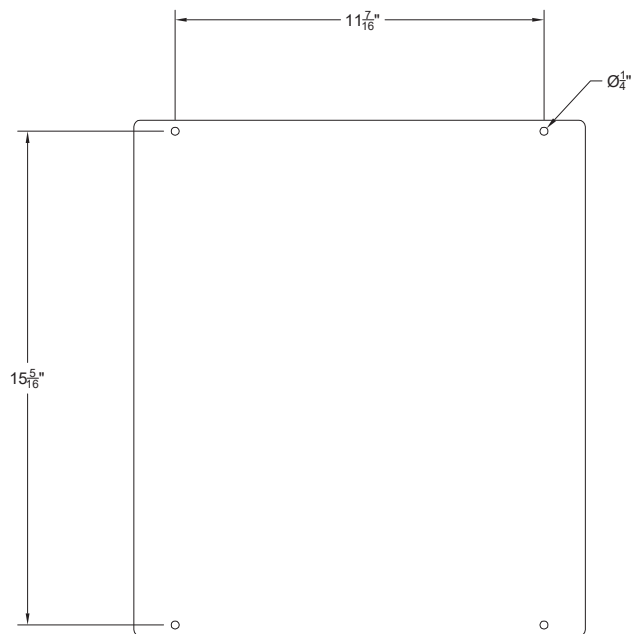

PANEL BACK

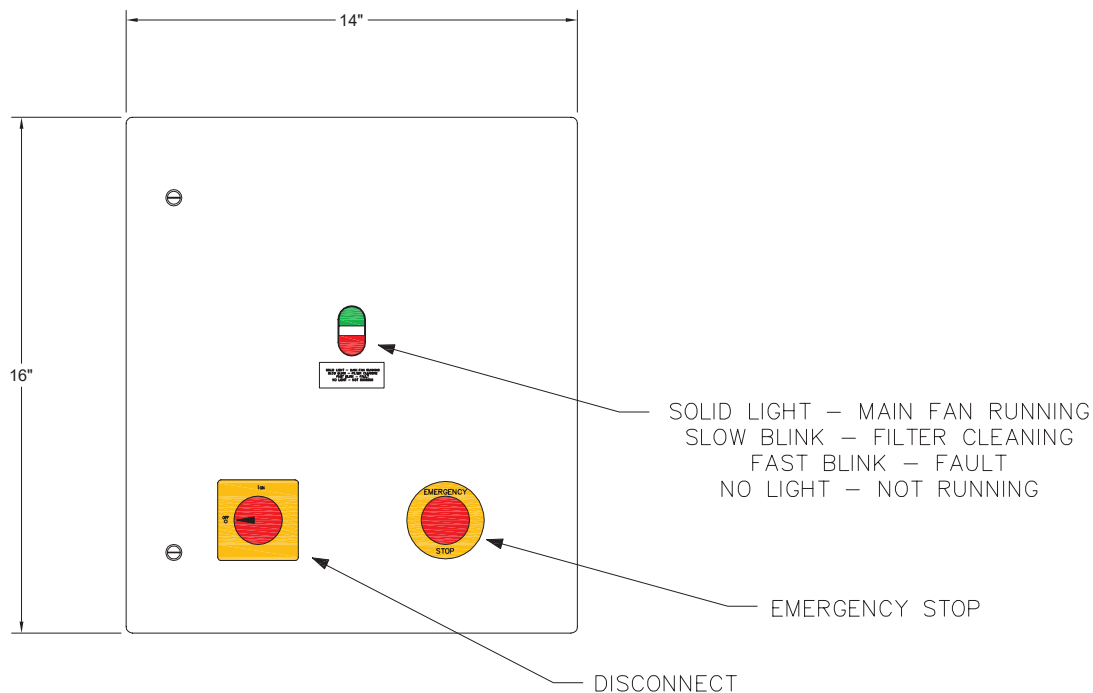

PANEL FRONT

SOLID LIGHT – MAIN FAN RUNNING
 SLOW BLINK – FILTER CLEANING
 FAST BLINK – FAULT
 NO LIGHT – NOT RUNNING

EMERGENCY STOP

DISCONNECT



4404A Chesapeake Dr
 Charlotte, NC 28216
 TEL: (336) 821-0800
 FAX: (336) 821-0890

Drawn by:	Date	Name	OPTION: SHAKER
Checked by:	7/31/20	D. LUMIA	
This drawing is confidential and is the exclusive property of Nederman LLC. No unauthorized use/copy or disclosure is to be made and it is returned whenever required.			

Title: NFPZ – CONTROL PANEL		Drawing Number: 89219034
Size A	Scale NTS	

Explosion Isolation Flap Valve CARZ-N - protective system



PATENTED PRODUCT

Patent protected product:

- EP patent: EP 3 343 077
- USA: US 10 315 059
- China: 201711349554.2

Explosion Isolation Flap Valve type CARZ-N is designed as an explosion pressure resistance equipment, which is able to prevent the transmission of dangerous effects from an explosion pressure wave and flame front to upstream areas. Certified according to EN 16447.

Description

Welded construction in RAL 5009 blue painted steel plate.

Function

During airflow generated by main fan, the Flap plate is open. In case of an explosion in the downstream equipment (e.g. dust collector) a pressure wave will force the Flap plate to close and lock in position. Large opening angle ensures low pressure drop. When Flap plate is closed it makes an effective barrier against approaching flame front. This prevents the explosion from being transmitted to upstream work areas, protecting workers, machinery and the facility.

Suction direction

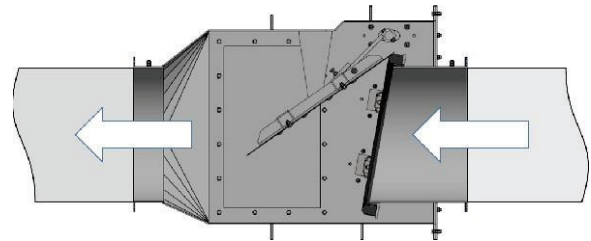

Explosion direction

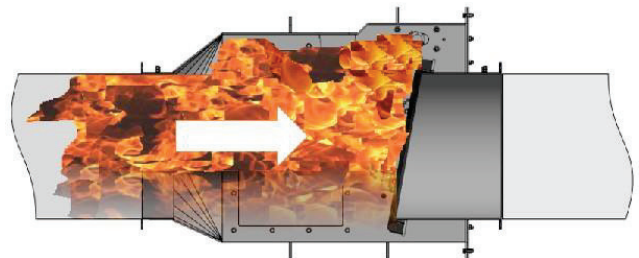

Marking, external zone 21

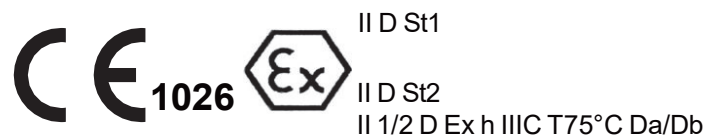

Ex h IIIC T75°C Da/Db

The marking is based on product certification:

- **FTZU 16 ATEX 0192X** by N.B. No. 1026 and Quality System approval by N.B.
- **IECEX FTZU 17.0015X** - Product certification according to International Certification System IECEx.

Special installation requirements

PULL configuration



PUSH configuration

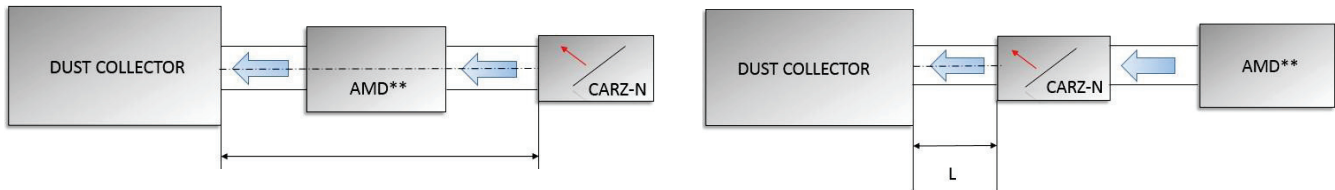

**AMD=Air moving device or fan

Parameters

Parameter	Dust type	Size 315 mm	Size 350 - 450 mm	Size 500 - 1000 mm
L min	Organic	5 m (16.4 ft) for PULL & PUSH	5,5 m (18 ft) for PULL 5 m (16.4 ft) for PUSH	5,5 m (18 ft) for PULL 5 m (16.4 ft) for PUSH
	Metallic	5,3 m (17.4 ft) only for PULL	5,5 m (18 ft) only for PULL	N/A
L max	Organic	10,2 m (33.5 ft) for PULL 10 m (32.8 ft) for PUSH	10 m (32.8 ft) for PULL & PUSH	10 m (32.8 ft) for PULL & PUSH
	Metallic	10,3 m (33.8 ft) only for PULL	10,5 m (34.5 ft) only for PULL	N/A
Max. flow velocity		30 m·s⁻¹ (5,906 fpm)		
Max. number of bends (between CARZ-N and protected vessel)		straight duct with max. 2 bends 90 dgr		

Parameter	All sizes
Max. flow velocity	30 m·s ⁻¹ (5,906 fpm)
Max. number of bends (between CARZ-N and protected vessel)	straight duct with max. 2 bends 90 dgr
Operating temperature range	-20°C to +60°C
Ambient Temperature	
Inclination of the CARZ-N	Horizontally

Specifications

Pull flow situation with nonmetallic dust

Diameter [mm]	Dust explosion class	Max. K_{st} [bar·m/s]	$P_{red\ max}^*$ [bar]	Max. dust concentration in duct	Min. Vessel [m³]	Explosion shock resistance pressure [bar]	Max. MESG** [mm]	Min. installation distance [m]	Max. installation distance [m]
315	St2	300	0,5	any	0,46	1	1,3	5	10,2
350	St1	200	0,5	any	0,9	1	1,3	5,5	10
350	St2	300	0,4	<LEL***	0,9	1	1,3	5,5	10
400	St1	200	0,5	any	0,9	1	1,3	5,5	10
400	St2	300	0,4	<LEL***	0,9	1	1,3	5,5	10
450	St1	200	0,5	any	0,9	1	1,3	5,5	10
450	St2	300	0,4	<LEL***	0,9	1	1,3	5,5	10
500	St1	200	0,5	any	1,6	1	1,3	5,5	10
500	St2	300	0,4	<LEL***	1,6	1	1,3	5,5	10
560	St1	200	0,5	any	1,6	1	1,3	5,5	10
560	St2	300	0,4	<LEL***	1,6	1	1,3	5,5	10
630	St1	200	0,5	any	1,6	1	1,3	5,5	10
630	St2	300	0,4	<LEL***	1,6	1	1,3	5,5	10
710	St1	200	0,35	any	3,2	0,7	1,8	5,5	10
800	St1	200	0,35	any	3,2	0,7	1,8	5,5	10
900	St1	200	0,35	any	3,2	0,7	1,8	5,5	10
1000	St1	200	0,35	any	3,2	0,7	1,8	5,5	10

* Maximum explosion reduced pressure on protected vessel

**Maximum Experimental Safe Gap

***Lower Explosion Limit = MEC Minimum Explosion Concentration

Protection method of connected vessel: Explosion vents or Explosion doors (not self-closing type)

Pull flow situation with metallic dust

Diameter [mm]	Dust explosion class	Max. K_{st} [bar·m/s]	$P_{red\ max}^*$ [bar]	Max. dust concentration in duct	Min. Vessel [m³]	Explosion shock resistance pressure [bar]	Max. MESG** [mm]	Min. installation distance [m]	Max. installation distance [m]
315	St2	260	0,5	<LEL***	0,96	1	1,3	5,3	10,3
350	St2	260	0,5	<LEL***	0,96	1	1,3	5,5	10,5
400	St2	260	0,5	<LEL***	0,96	1	1,3	5,5	10,5
450	St2	260	0,5	<LEL***	0,96	1	1,3	5,5	10,5

* Maximum explosion reduced pressure on protected vessel

**Maximum Experimental Safe Gap

***Lower Explosion Limit = MEC Minimum Explosion Concentration

Protection method of connected vessel: Explosion vents or Explosion doors (not self-closing type)

Push flow situation with nonmetallic dust

Diameter [mm]	Dust explosion class	Max. K _{st} [bar·m/s]	P _{rod max} * [bar]	Max. dust concentration in duct	Min. Vessel [m³]	Explosion shock resistance pressure [bar]	Max. MESG** [mm]	Min. installation distance [m]	Max. installation distance [m]
315	St2	300	0,5	any	0,46	1	1,3	5	10
350	St1	200	0,5	any	1,6	1	1,3	5	10
400	St1	200	0,5	any	1,6	1	1,3	5	10
450	St1	200	0,5	any	1,6	1	1,3	5	10
500	St1	200	0,5	any	1,6	1	1,3	5	10
560	St1	200	0,5	any	1,6	1	1,3	5	10
630	St1	200	0,5	any	1,6	1	1,3	5	10
710	St1	200	0,4	any	3,2	0,7	1,8	5	10
800	St1	200	0,4	any	3,2	0,7	1,8	5	10
900	St1	200	0,4	any	3,2	0,7	1,8	5	10
1000	St1	200	0,4	any	3,2	0,7	1,8	5	10

* Maximum explosion reduced pressure on protected vessel

**Maximum Experimental Safe Gap

***Lower Explosion Limit = MEC Minimum Explosion Concentration

Protection method of connected vessel: Explosion vents or Explosion doors (not self-closing type)

MESG (mm) is calculated from MIE (mJ) and MIT (°C) using the following equation (Eckhoff, 2003)****:

$$MESG = 1,01 \times (MIE \times (MIT + 273) / 273) ^ 0,157$$

Dimensions

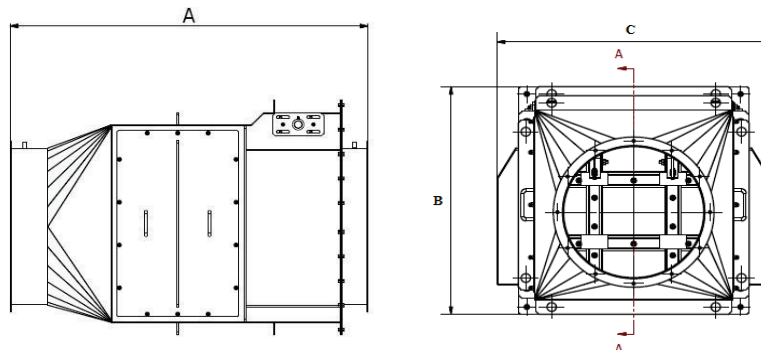

Flap valve size ØD	Dimensions [mm]			Weight [kg]	Maximum Equipment category*	Part number		
	A	B	C			FL	NW	QF
315 mm	1095	643	857	140	2	73008407	73008408	73008413
350 mm	1105	685	895	145	2	73008409	73008410	73008414
400 mm	1115	715	948	157	2	73008411	73008412	73008415
450 mm	1109	1118	973	175	2	73007816	73007817	N/A
500 mm	1193	1168	1012	200	2	73007839	73007840	N/A
560 mm	1294	1228	1040	224	2	73007845	73007846	N/A
630 mm	1409	1298	1129	260	2	73007851	73007852	N/A
710 mm	1489	1124	1270	380	2	73008055	73008056	N/A
800 mm	1554	1214	1354	431	2	73008058	73008059	N/A
900 mm	1636	1320	1451	490	2	73008060	73008061	N/A
1000 mm	1805	1410	1540	566	2	73008062	73008063	N/A

* Sizes 450-1000 for category 3 with IEC EX certificate on special request.

NOTE. Category 3 - normal level of protection zone 2 or 22, category 2 - high level of protection zone 1,2 or 21,22 according to 2014/34/EU.

FL - bolted flange,

QF - flange for Quick Fittings type ducting system,

NW - bolted flange according to standard DIN 24154-R2.

Chart of pressure drop vs. velocity

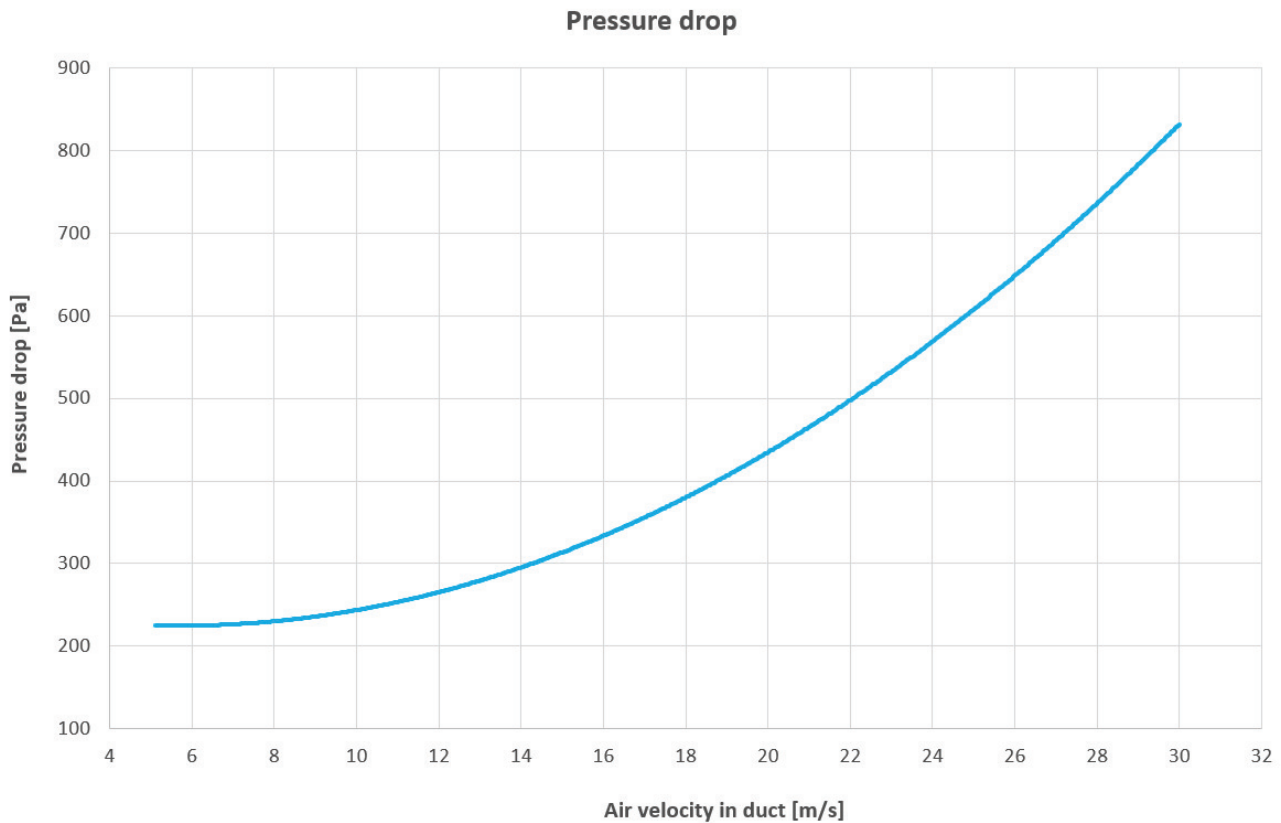

Accessories

Manufacturer offers accessories that must be ordered separately:

- Flap lock indicator II 2 D-Ex tb IIIC T85°C Db, IP66/67 - part number: **73007978**.
- Flap lock indicator not for an external explosive atmosphere - part number: **73007979**.

Contact Nederman for other configurations with dust build-up sensor for NFPA 69 compliance.

18" (450mm) Dia FLANGED CARZ N EXPLOSION ISOLATION FLAP

WEIGHT: 386 lb

18" (450mm) CARZ N PART #
 ST1: 73007814
 ST2: 73007816
 LOCK INDICATOR ZONE 22
 EXTERNAL PART #: 73007978
 LOCK INDICATOR NON-ZONE IFS
 PART #: 73007979

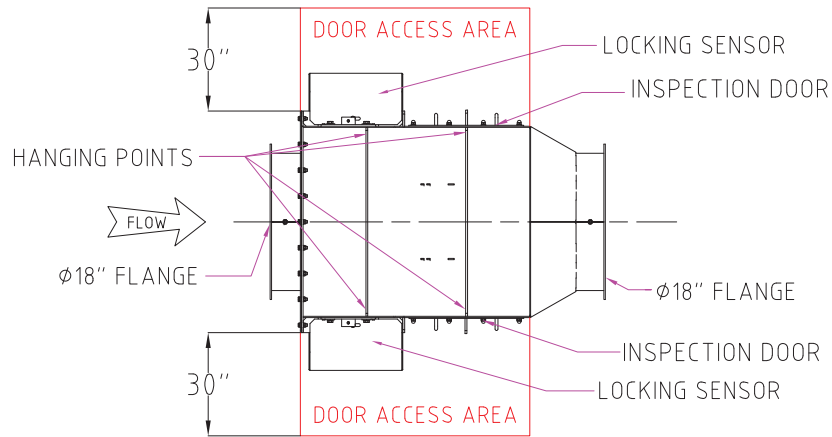

PLAN VIEW

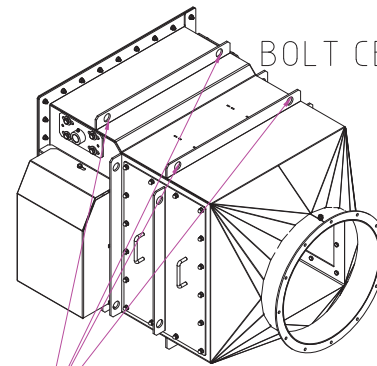

BOLT HOLES ARE SPACED 30 DEGREES APART

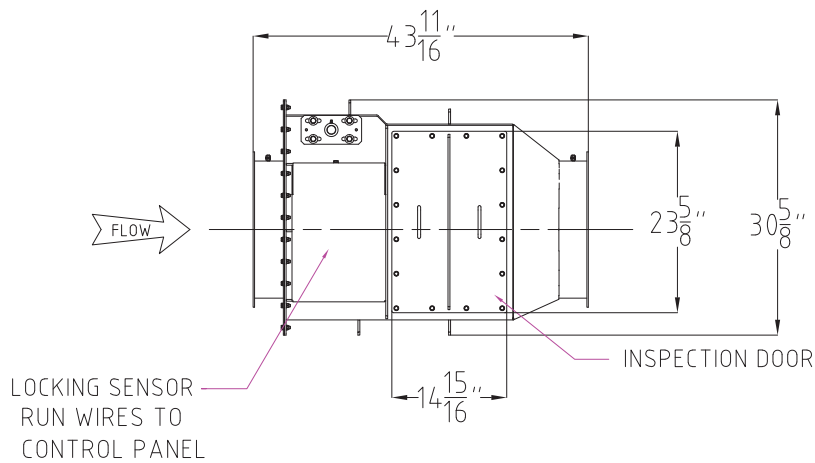

SIDE VIEW

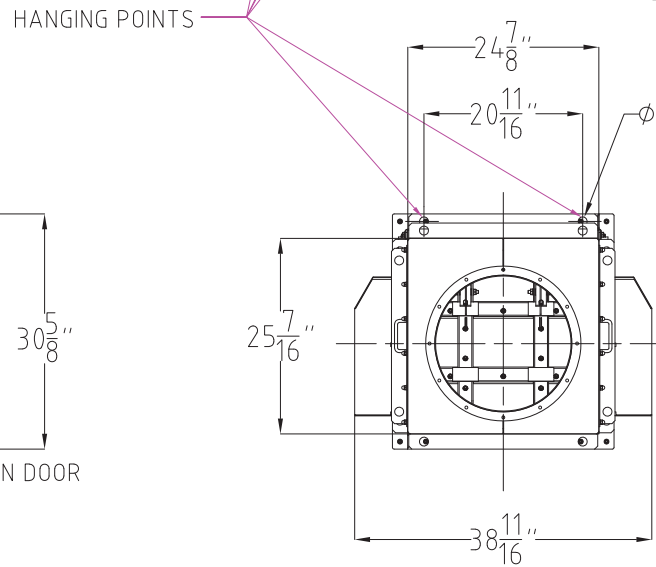

END VIEW

NOTES:

- MUST BE INSTALLED AT A MAX OF 32' FROM THE COLLECTOR INLET, AND A MIN OF 18' FOR NEG CONFIG AND 16.4' FOR POS CONFIG, WITH NO MORE THAN TWO ELBOWS (90°).
- LOCKING SENSOR PIN. CONNECT TO CONTROL PANEL.
- CONSULT TECHNICAL LEAFLET FOR INSTALLATION GUIDELINES.

COMPONENT PLACEMENT

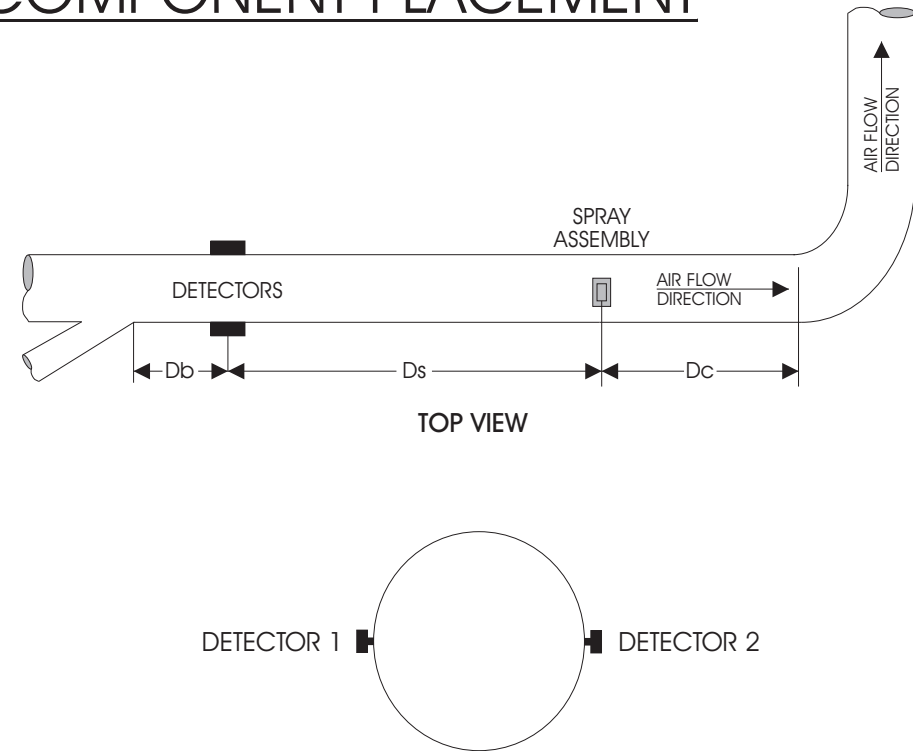

CALCULATION FOR COMPONENT PLACEMENT (MINIMUM DISTANCES)	
AIRFLOW VOLUME	7400 cfm
DIAMETER OF DUCT	18"
AIR SPEED	4188 feet per minute
Minimum Distance DETECT TO SPRAY DISTANCE (Ds)	21 feet
STRAIGHT DUCT DOWNSTREAM FROM SPRAY (Dc)	5 feet
LAST BRANCH DIAMETER	TBD
BRANCH TO DETECTOR DISTANCE (Db)	4 feet
TOTAL DISTANCE REQUIRED (Db + Ds + Dc)	30 feet

BILL OF MATERIALS			
ITEM	PART #	DESCRIPTION	QTY
1	AN104	One Zone Control Panel	1
2	120-1	Infra-red Spark Detector	2
3	901-1	Water Spray Assembly	1
4	902-1	Deluge Water Spray Assembly	0
5	922-1	1" Ball Valve & Supervisory Switch	1
6	920-1	Water Flow Switch	0
7	930-1	Heat Detector - 190 °F	0
8	940-1	4.5 Amp Hour Batteries	1
9	910-1	24 Volt Alarm Horn	1

GENERAL NOTES

- Dust collecting or conveyance duct velocities must be confirmed prior to Spark Detection System installation.
- All wiring shall be as per all local and National electrical codes. An earth ground is required regardless of local code requirements.
- All panels, enclosures, conduits and devices shall be grounded to a good earth ground.
- All low voltage wiring to Detectors, Horns, Spray Assemblies and inputs must be in metallic conduit and at least 24" away from high voltage lines (above 400 volts).
- A clean, uninterrupted source voltage must be used. The circuit breaker must be dedicated to the Spark Detection System and must be lockable.
- All wiring to abort dampers and starters must be taken from a separate electrical circuit. No electrical needs can be sourced from the circuit breaker that is being used by the Spark Detection Panel.
- Installation and equipment must conform to the requirements of the Authority Having Jurisdiction.
- Notes are to be read in conjunction with the installation and user manual.

WIRING

DET. 1	DET. 2	DET. 3	DET. 4	FLOW	HEAT	AUX	AN104	SPRAY	SPRAY	HORN	ALARM	TROUBLE	SHUTDOWN	ABORT
+ S	- S	+ S	- S	+ -	+ -	+ -		+ 1	+ 2	+ -	N/C	N/O	N/C	N/O
⊗	⊗	⊗	⊗	⊗	⊗	⊗		⊗	⊗	⊗	⊗	⊗	⊗	⊗

DETECTOR WIRING

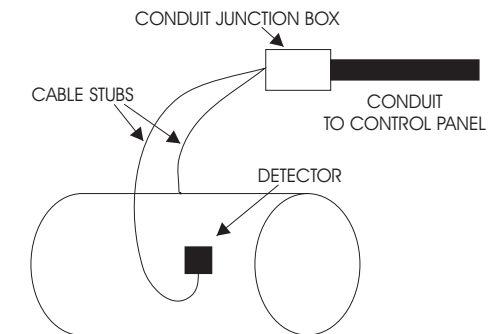
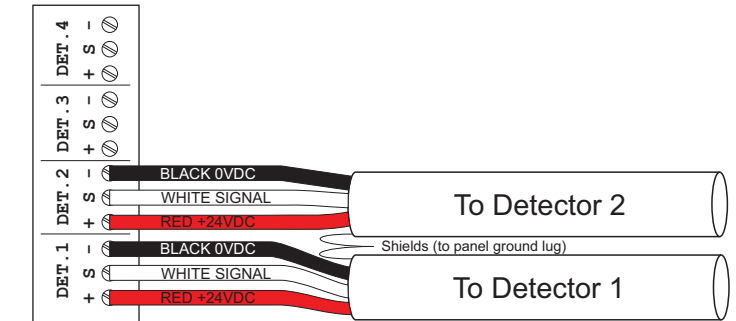

HANSENTEK

THE AN104 SPARK DETECTION SYSTEM

Revision: 0	Date: February 18, 2026	By: HS
Waterdown District High School 2 c/o Nederman Inc		
SERIAL #: TBD	DRW #: IID085035SY	
	FM file# 3044485	
Checked By: RF	Sheet 1 of 6	

INPUT WIRING

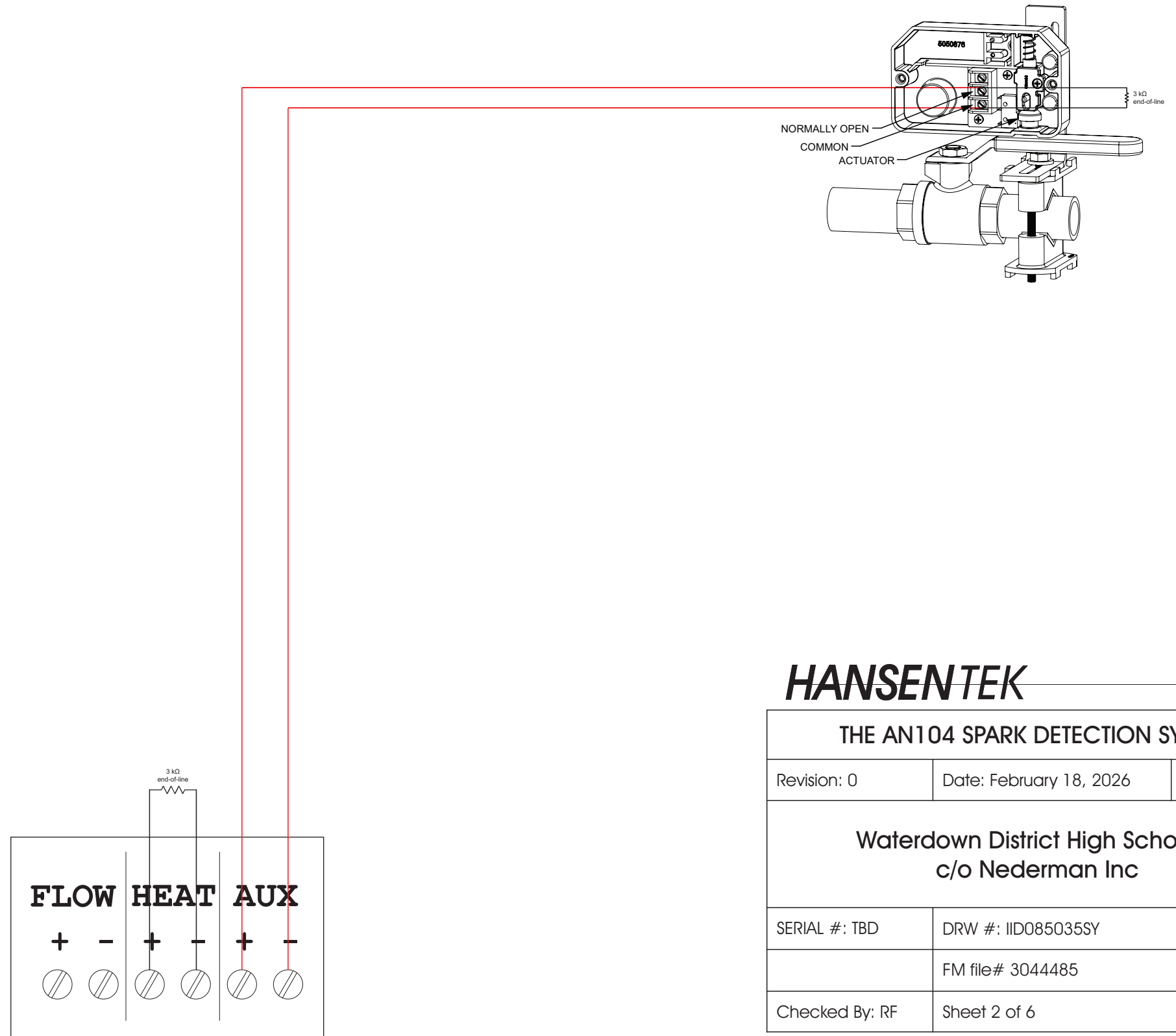

HANSENTEK 

THE AN104 SPARK DETECTION SYSTEM

Revision: 0	Date: February 18, 2026	By: HS
-------------	-------------------------	--------

Waterdown District High School 2
c/o Nederman Inc

SERIAL #: TBD	DRW #: IID085035SY
---------------	--------------------

FM file# 3044485

Checked By: RF	Sheet 2 of 6
----------------	--------------

GENERAL PLUMBING NOTES

SPRAY WIRING

1. The water pressure at the valve must be at least 50 PSI and must not exceed 125 PSI. The water supply must deliver a minimum of 16.6 US gallons per minute per nozzle. A pressure reducer must be used if water pressure exceeds 125 PSI.

2. Water pipe, strainers, valves and nozzles installed outside must be heat traced and insulated. Heat tracing and insulation must be adequate to withstand the temperature extremes and environmental conditions of the area where it is installed.

Note: A Glycol loop must not be used.

3. Strainer must be connected directly to solenoid valve. The solenoid valve must connect directly to the nozzle. Nozzle to be installed at the top of the duct.

4. Piping and fittings must conform to ASTM and NFPA standards. Minimum water supply line for a single nozzle should be 3/4" but 1" is preferred.

5. Notes to be read in conjunction with installation and user manual.

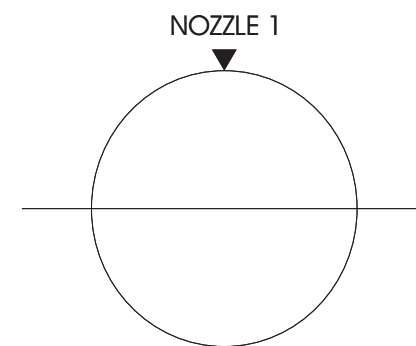
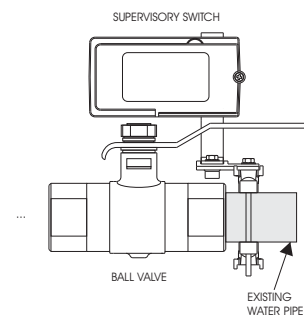
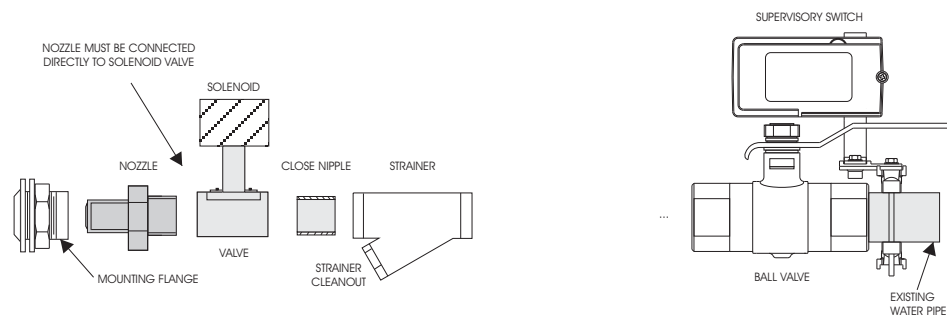
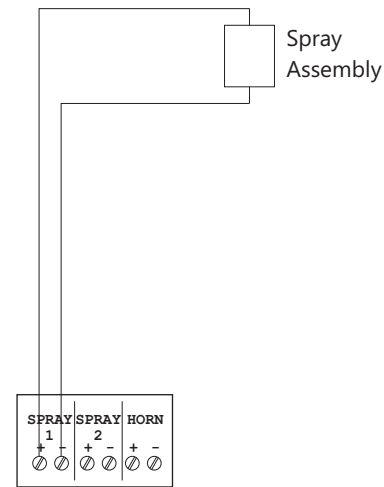

HANSENTEK

THE AN104 SPARK DETECTION SYSTEM

Revision: 0	Date: February 18, 2026	By: HS
-------------	-------------------------	--------

**Waterdown District High School 2
c/o Nederman Inc**

SERIAL #: TBD	DRW #: IID085035SY
---------------	--------------------

FM file# 3044485

Checked By: RF	Sheet 3 of 6
----------------	--------------

GENERAL ELECTRICAL NOTES

1. No branching of wires permitted on supervised circuits. End of Line resistors must be at the last device in order to detect an open circuit. Remove any temporary End of Line resistors in the control panel when any input circuit is connected.
2. Field wiring must be checked for shorts or grounds before connecting to the control panel. DO NOT MEGGER LINES.
3. Detector wires shall be run in separate conduit away from all high voltage wiring. Spray Assembly wiring may be in the same conduit.
4. The Main Control Unit should be mounted on a wall, at least 48 inches away from any high voltage sources (greater than 400 volts).
5. Wiring minimum sizes: Power Input - 14 AWG/600 Volts; Detectors - 18 AWG stranded and shielded; Auxiliary Inputs, Horn, Alarm/Trouble - 18 AWG; All other wiring - 14 AWG.
6. Notes to be read in conjunction with installation and user manual.

ABORT DAMPER WIRING

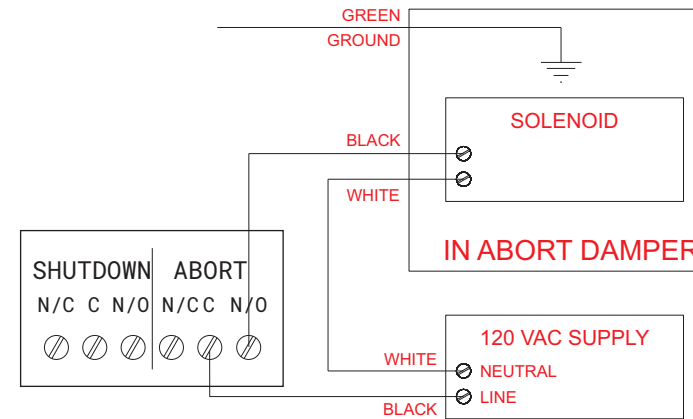

SHUTDOWN WIRING

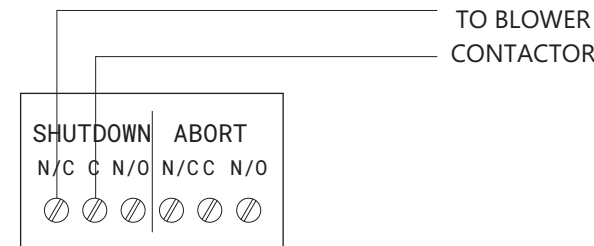

HANSENTEK 

THE AN104 SPARK DETECTION SYSTEM

Revision: 0	Date: February 18, 2026	By: HS
-------------	-------------------------	--------

Waterdown District High School 2
c/o Nederman Inc

SERIAL #: TBD	DRW #: IID085035SY
---------------	--------------------

FM file# 3044485

Checked By: RF	Sheet 4 of 6
----------------	--------------

SYSTEM WIRING

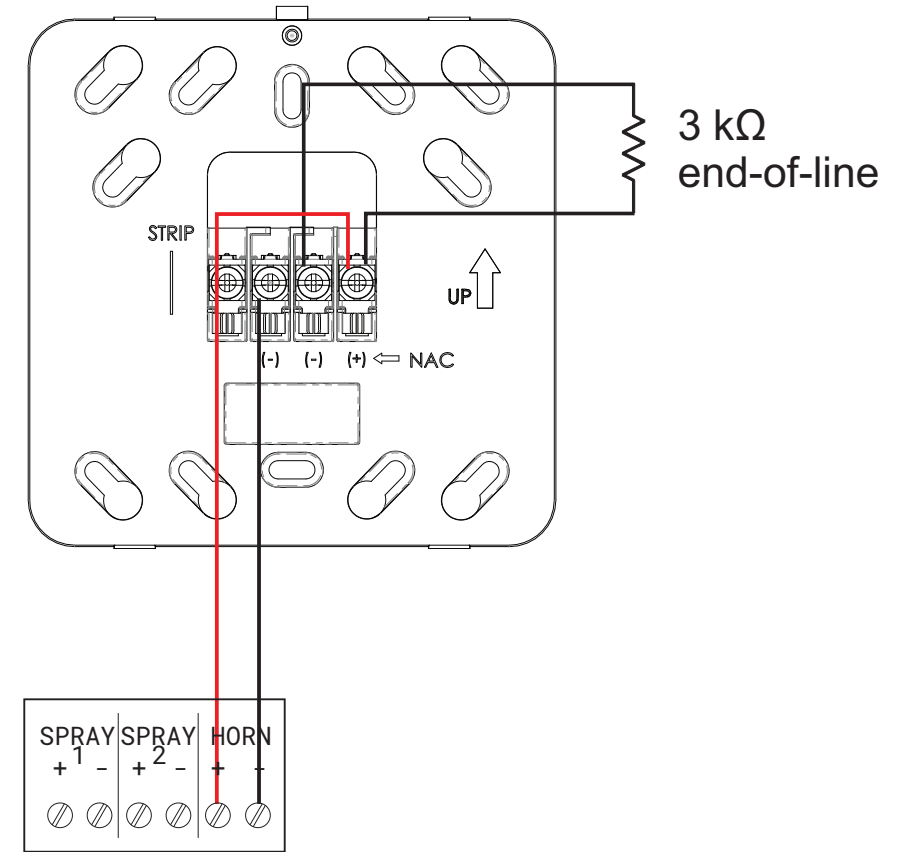
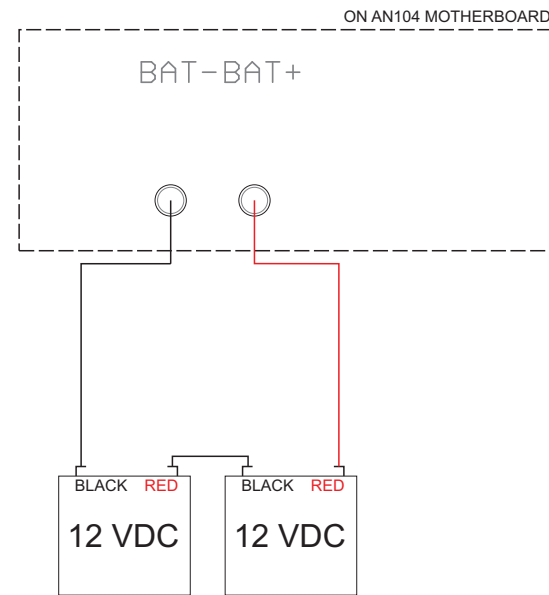
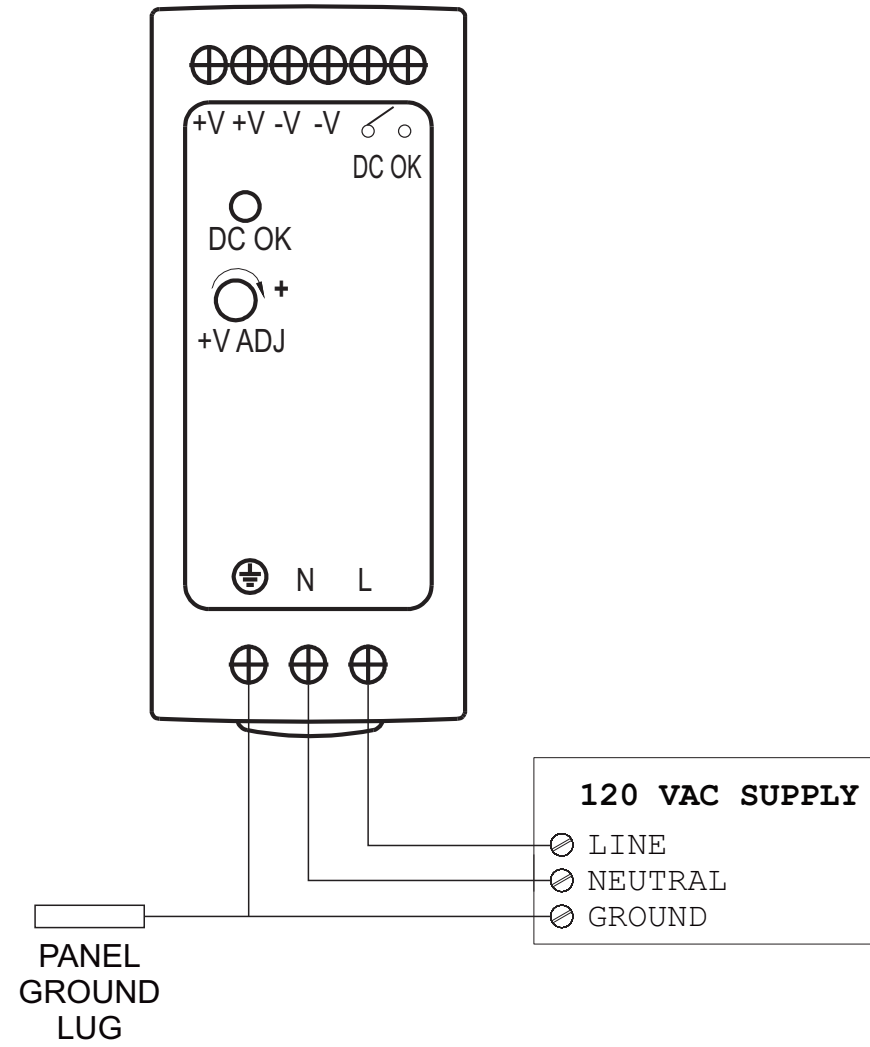

HANSENTEK 

THE AN104 SPARK DETECTION SYSTEM

Revision: 0 Date: February 18, 2026 By: HS

Waterdown District High School 2
c/o Nederman Inc

SERIAL #: TBD DRW #: IID085035SY

FM file# 3044485

Checked By: RF Sheet 5 of 6

SWITCH SETTINGS

SWITCH #:	1	2	3	4	5	6	7	8	9	10	11	12
Spray 2 Seconds												
Spray 5 Seconds	0	1										
Spray 10 Seconds												
Spray 30 Seconds												
Two Detectors			0									
Four Detectors												
Flow Monitoring												
No Flow Switch				1								
Output 2 (S2) is Second Spray					0							
Output 2 (S2) is Deluge												
Deluge 10 minutes												
Deluge Continuous – until reset						1						
Shutdown on 1 Spray							0					
Shutdown on 4 sprays in 5 minutes												
Shutdown/Abort on D3, D4 only												
Shutdown on D1, D2, D3 or D4								1				
Auto Self-Test On												
Auto Self-Test Off									1			
Abort 10 Seconds										0		
Abort Until Clear												
Enable Spray 1											0	
Disable Spray 1												
Enable Spray 2												
Disable Spray 2												1

HANSENTEK 

THE AN104 SPARK DETECTION SYSTEM

Revision: 0 Date: February 18, 2026 By: HS

**Waterdown District High School 2
c/o Nederman Inc**

SERIAL #: TBD DRW #: IID085035SY

FM file# 3044485

Checked By: RF Sheet 6 of 6

Silencer

Ordering Information

- When ordering, specify material, gauge (if non-standard), dimension and end type.
- Reduces noise created by air movement inside the duct. Due to varying applications, no decibel testing has been performed on this product.
- Air flow directional arrow sticker is attached to product.



Ø in.	B OD in.	C Body Length in.	D (QF) in.	D (AFL/FFL) in.	Std Weight Lbs
3	11	24	2	3.5 (for each end)	10
4	12	24			21
5	13	24			35
6	14	26			43
7	15	26			54
8	16	31			65
9	17	36			76
10	18	44			89
11	19	50			96
12	20	50			104
13	21	54			113
14	22	54			122
15	23	60			149
16	24				176
17	25				201
18	26		225		
19	27		245		
20	28		265		
21	29		288		
22	30		310		
23	31		358		
24	32		406		
26	34	4	546		
28	36	4	600		
30	38	N/A	678		
32	40		700		
34	42		770		
36	44		897		
38	46		974		
40	48		1118		

QF Material Options

Galv (Collar)				SS (Collar)			
Gauges	Size (in)		Gauges	Size (in)			
	Min. Ø	Max. Ø		Min. Ø	Max. Ø		
Standard	20	3	16	Standard	20	3	16
	16	17	40		16	17	40

Flanged Material Options

Galv (Collar)				SS (Collar)			
Gauges	Size (in)		Gauges	Size (in)			
	Min. Ø	Max. Ø		Min. Ø	Max. Ø		
Standard	20	3	16	Standard	20	3	16
	16	17	40		16	17	40

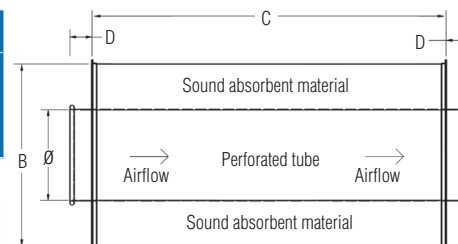

Construction

Collars: Caulked and painted.

Outer Tube: On 16" diameter pipe and all smaller sizes, longitudinal seam is laser welded. On 17" and greater, seam is plasma welded. The outer tube gauge is 20ga for sizes 3" - 16" and 16ga for sizes 17" and larger.

Cover Plate: Not intended to be removeable. 16ga construction.

Optional End Types: Standard QF end can be changed to Raw ID (RI), Raw OD (RO), No Fitting (NF), Hose Adapter (RF), Flat Flange (FFL), Angle Flange (AFL), or Van Stone (VS).

IF IN DOUBT ASK

General Notes:

Design standards are based upon the following two reference manuals:

- SMACNA, (2013). *Round Industrial Duct Construction Standards*, (3rd ed.).
- ACGIH, (2019). *Industrial Ventilation: A Manual of Recommended Practice for Design* (30th ed.).

All tables, figures, and recommendations shown in this document are based upon SMACNA, (2013). *Round Industrial Duct Construction Standards*, (3rd ed.).

Class II dust is assumed throughout this document.

Manual blast gates are provided by Nederman to balance the dust collection system. Under no circumstance should ANY blast gates be adjusted without first consulting a Nederman engineer. Failure to comply may result in decreased system performance and/or material build up in the ductwork, potentially leading to failure of the system.

The main trunk of the dust collection system should be inspected monthly for material build up.

General Hanging Notes:

All ductwork should be supported by an appropriate method capable of handling the weight of pipe partially filled with material. These supports should occur at an interval no greater than 10ft. Additional support is required at each branch and vertical drop. More frequent support may be necessary depending on the particular geometric or structural requirements of the installation site or if the bulk material density is greater than 25 lb/ft³. Seismic requirements are not included.

Ductwork is assumed to hang with the centerline 10ft below the bottom of the roof support structure.

Lateral ductwork supports should occur every 20 linear feet of ductwork.

Duct support design is based upon a bulk material density of 25 lb/ft³ with the main trunk line 25% full. If the material being collected is heavier, then an appropriate change to the duct support method may need to occur.

It is the installer's responsibility to employ an appropriate method to support the ductwork which meets the minimum standards outlined in this document.

Hardware used to support ductwork should a minimum of SAE Grade 5.

If explosive dust is present, the Nederman CARZ damper must be supported both vertically AND laterally in parallel with the duct.

Connection to the roof supports must be by an appropriate method that does not exceed the structural capacity of the roof structure.

It is the customer's responsibility to ensure that the roof structure is capable of supporting the weight of the dust collection system.

5865 McLaughlin Road
Mississauga, ON L5R 1B8
TEL: +1 (855) 925-1609
FAX: +1 (905) 366-2206

This drawing is confidential and the exclusive property of Nederman, Inc. No unauthorized use/copy or disclosure is to be made and it is to be returned whenever required.

TOLERANCE
ALL DIMS IN INCHES
.X ±.063
.XX ±.031
.XXX ±.015
ANGULAR ±1°
UNLESS OTHERWISE
SPECIFIED

Material:		Rev: A		Scale: NTS	
	NAME	DATE			
DRAWN:	M. Davidson	2/27/2020	Sheet #:	Size: A	
CHECKED:	R. Williamson		1 of 8		

Title: General Notes for Ductwork Installation	
Part Number:	Drawing Number: DUCT_GUIDELINES

IF IN DOUBT ASK

Table 1. Nordfab QF Duct Weight L = 5ft

Diameter	Gage	Weight 0% Fill	Weight 25% Fill	Weight 50% Fill
[in]	[ga]	[lbs]	[lbs]	[lbs]
3	22	4.00	5.53	7.07
4	22	5.35	8.08	10.80
5	22	6.65	10.91	15.17
6	22	7.93	14.07	20.20
7	22	11.70	20.05	28.40
8	22	13.25	24.16	35.07
8	14	36.00	46.91	57.82
9	22	14.92	28.73	42.53
9	14	40.00	53.81	67.61
10	22	16.60	33.64	50.69
10	14	44.00	61.04	78.09
11	22	18.10	38.72	59.35
11	14	49.00	69.62	90.25
12	22	19.75	44.29	68.84
12	14	53.00	77.54	102.09
13	20	21.40	50.20	79.01
13	14	57.00	85.80	114.61
14	20	27.30	60.71	94.11
14	14	61.00	94.41	127.81
15	20	29.25	67.60	105.95
15	14	66.00	104.35	142.70
16	20	31.15	74.78	118.42
16	14	70.00	113.63	157.27
17	20	33.09	82.35	131.61
17	14	74.00	123.26	172.52
18	20	34.00	89.22	144.45
18	14	79.00	134.22	189.45
19	20	36.00	97.53	159.06
19	14	83.00	144.53	206.06
20	20	38.00	106.18	174.35
20	14	87.00	155.18	223.35
21	20	40.00	115.17	190.33
21	14	92.00	167.17	242.33
22	20	42.00	124.49	206.99
22	14	96.00	178.49	260.99
23	20	44.00	134.16	224.33
23	14	100.00	190.16	280.33
24	20	45.82	143.99	242.17
24	14	104.00	202.17	300.35

*All weights are calculated per 5ft section of pipe.

Table 2. Nordfab AF Duct Weight L = 5ft

Diameter	Gage	Weight 0% Fill	Weight 25% Fill	Weight 50% Fill
[in]	[ga]	[lbs]	[lbs]	[lbs]
3	22	5.40	6.93	8.47
4	22	7.05	9.78	12.50
5	22	9.05	13.31	17.57
6	22	10.73	16.87	23.00
7	22	15.70	24.05	32.40
8	22	17.75	28.66	39.57
8	14	39.80	50.71	61.62
9	22	17.75	31.56	45.36
9	14	45.10	58.91	72.71
10	22	19.92	36.96	54.01
10	14	50.10	67.14	84.19
11	22	23.10	43.72	64.35
11	14	55.50	76.12	96.75
12	22	25.10	49.64	74.19
12	14	60.76	85.30	109.85
13	20	27.75	56.55	85.36
13	14	65.50	94.30	123.11
14	20	29.90	63.31	96.71
14	14	70.50	103.91	137.31
15	20	44.25	82.60	120.95
15	14	80.50	118.85	157.20
16	20	47.15	90.78	134.42
16	14	86.00	129.63	173.27
17	20	49.59	98.85	148.11
17	14	90.50	139.76	189.02
18	20	51.00	106.22	161.45
18	14	96.00	151.22	206.45
19	20	55.00	116.53	178.06
19	14	100.50	162.03	223.56
20	20	57.00	125.18	193.35
20	14	106.00	174.18	242.35
21	20	59.50	134.67	209.83
21	14	112.50	187.67	262.83
22	20	63.50	145.99	228.49
22	14	117.50	199.99	282.49
23	20	65.50	155.66	245.83
23	14	122.50	212.66	302.83
24	20	68.82	166.99	265.17
24	14	127.00	225.17	323.35

*All weights are calculated per 5ft section of pipe.

Table 2. Cont.

Diameter	Gage	Weight 0% Fill	Weight 25% Fill	Weight 50% Fill
[in]	[ga]	[lbs]	[lbs]	[lbs]
26	16	98.56	213.78	329.00
26	14	145.07	260.29	375.51
28	16	118.00	251.63	385.25
28	14	156.16	289.79	423.41
30	16	137.05	290.45	443.85
30	14	167.74	321.14	474.54
32	16	145.94	320.47	495.01
32	14	178.82	353.35	527.89
34	16	154.83	351.86	548.89
34	14	189.91	386.94	583.97
36	16	162.76	383.65	604.55
36	14	200.49	421.38	642.28
38	16	173.47	419.59	665.71
38	14	212.07	458.19	704.31
40	16	182.81	455.52	728.23
40	14	223.15	495.86	768.57

*All weights are calculated per 5ft section of pipe.

*Pipe weight calculations based on a material density of 25 lb/ft³.

*All flanged pipe is van stoned.

Table 3. Ducting Allowable Point Load

Diameter	Gage				
	[in]	22	20	16	14
3	0.3				
4	0.3				
5	0.3				
6	0.3				
7	0.3				
8	0.3				2.2
9	0.3				2
10	0.3				2
11	0.3				2
12	0.3				2
13		0.8			1.8
14		0.8			1.8
15		0.8			1.8
16		0.8			1.8
17		0.8			1.8
18		0.8			1.8
19		0.8			1.8
20		0.8			1.8
21		0.8			1.8
22		0.8			1.8
23		0.8			1.7
24		0.8			1.7
26			1		1.7
28			1		1.6
30			1		1.6
32			1		1.6
34			1		1.6
36			1		1.6
38			0.9		1.6
40			0.9		1.6

Note. Reproduced from *Round Industrial Duct Construction Standards, (3rd ed.) Table 13-1. Maximum Allowable Load at Points of Support – Carbon and Galvanized Steel Ducts.*

*Loads are in Kips and good to 400°F for galvanized steels. 1 Kip = 1,000 lbs.

*Loads have a multiplier of 1.5 if using support straps and the straps are installed no further than 6" from the angle ring.

Design standards are based upon the following two reference manuals:

- SMACNA, (2013). *Round Industrial Duct Construction Standards, (3rd ed.)*.
- ACGIH, (2019). *Industrial Ventilation: A Manual of Recommended Practice for Design (30th ed.)*.

Nederman
 5865 McLaughlin Road
 Mississauga, ON L5R 1B8
 TEL: +1 (855) 925-1609
 FAX: +1 (905) 366-2206

This drawing is confidential and the exclusive property of Nederman, Inc. No unauthorized use/copy or disclosure is to be made and it is to be returned whenever required.

TOLERANCE
 ALL DIMS IN INCHES
 .X ±.063
 .XX ±.031
 .XXX ±.015
 ANGULAR ±1°
 UNLESS OTHERWISE SPECIFIED

Material:

DRAWN:	M. Davidson	DATE	2/27/2020
CHECKED:	R. Williamson		

Rev:	A	Scale:	NTS
Sheet #:	2 of 8	Size:	A

Title:

Pipe Weights

Part Number:

Drawing Number:

DUCT_GUIDELINES

IF IN DOUBT ASK

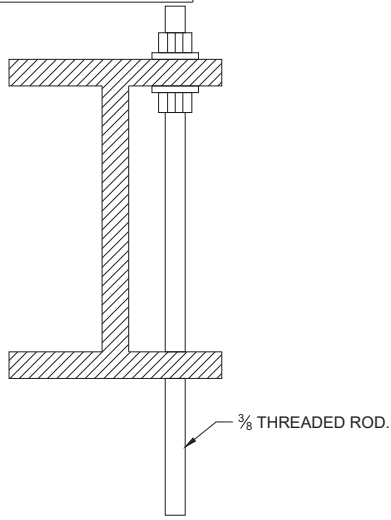

Direct Threaded Rod Method

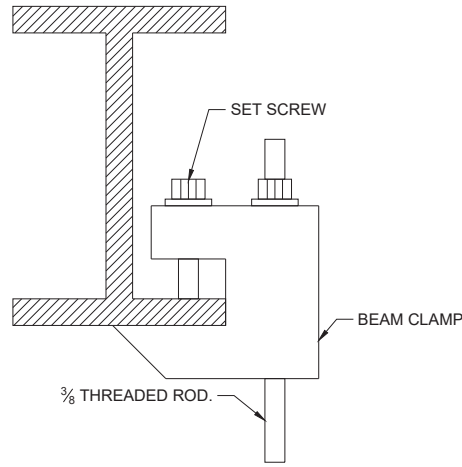

Beam Clamp Method

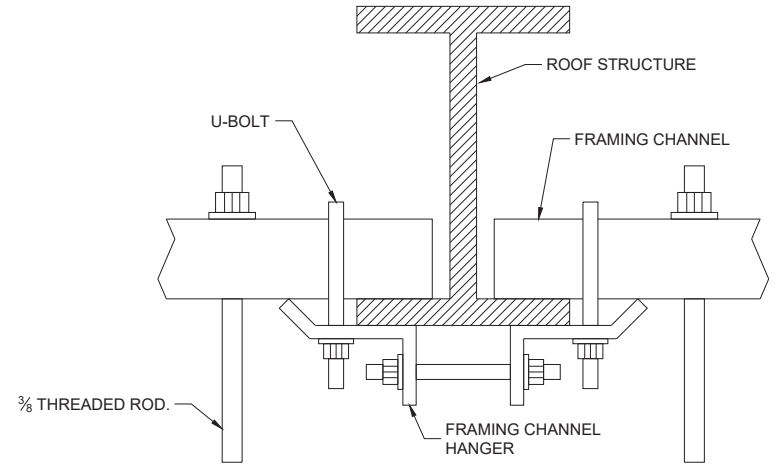

Framing Channel Method

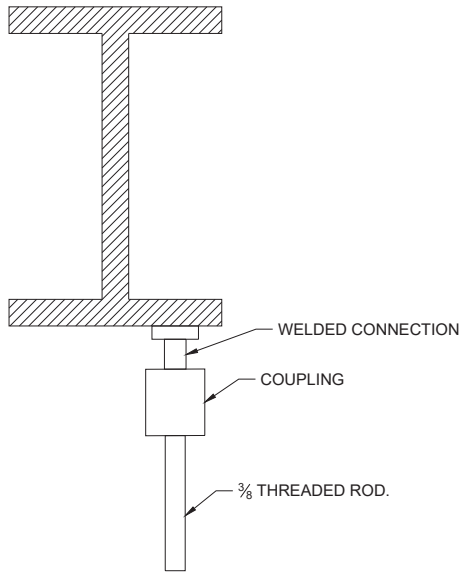

Welding Method

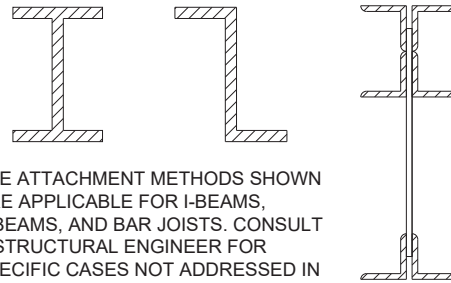

THE ATTACHMENT METHODS SHOWN ARE APPLICABLE FOR I-BEAMS, Z-BEAMS, AND BAR JOISTS. CONSULT A STRUCTURAL ENGINEER FOR SPECIFIC CASES NOT ADDRESSED IN THIS DOCUMENT.

FIGURES ON THIS PAGE REPRESENT SOME POSSIBLE ROOF ATTACHMENT METHODS AND SHOULD NOT BE CONSIDERED A COMPLETE SELECTION. IT IS THE INSTALLER'S RESPONSIBILITY TO DETERMINE THE MOST APPROPRIATE METHOD BASED ON EACH INSTALLATION SITE.

ALL HARDWARE SHOULD BE SAE GRADE 5 MINIMUM.

IT IS THE CUSTOMER'S RESPONSIBILITY TO ENSURE THAT THE ROOF STRUCTURE IS CAPABLE OF SUPPORTING THE WEIGHT OF THE DUST COLLECTION SYSTEM.

Design standards are based upon the following two reference manuals:

- SMACNA, (2013). *Round Industrial Duct Construction Standards*, (3rd ed.).
- ACGIH, (2019). *Industrial Ventilation: A Manual of Recommended Practice for Design* (30th ed.).



5865 McLaughlin Road
Mississauga, ON L5R 1B8
TEL: +1 (855) 925-1609
FAX: +1 (905) 366-2206

This drawing is confidential and the exclusive property of Nederman, Inc. No unauthorized use/copy or disclosure is to be made and it is to be returned whenever required.

TOLERANCE
ALL DIMS IN INCHES
.X ±.063
.XX ±.031
.XXX ±.015
ANGULAR ±1°
UNLESS OTHERWISE SPECIFIED

Material:

	NAME	DATE	Rev:	Scale:
DRAWN:	M. Davidson	2/27/2020	A	NTS
CHECKED:	R. Williamson		Sheet #:	Size:
			3 of 8	A

Title:

Roof Attachments

Part Number:

Drawing Number:

DUCT_GUIDELINES

IF IN DOUBT ASK

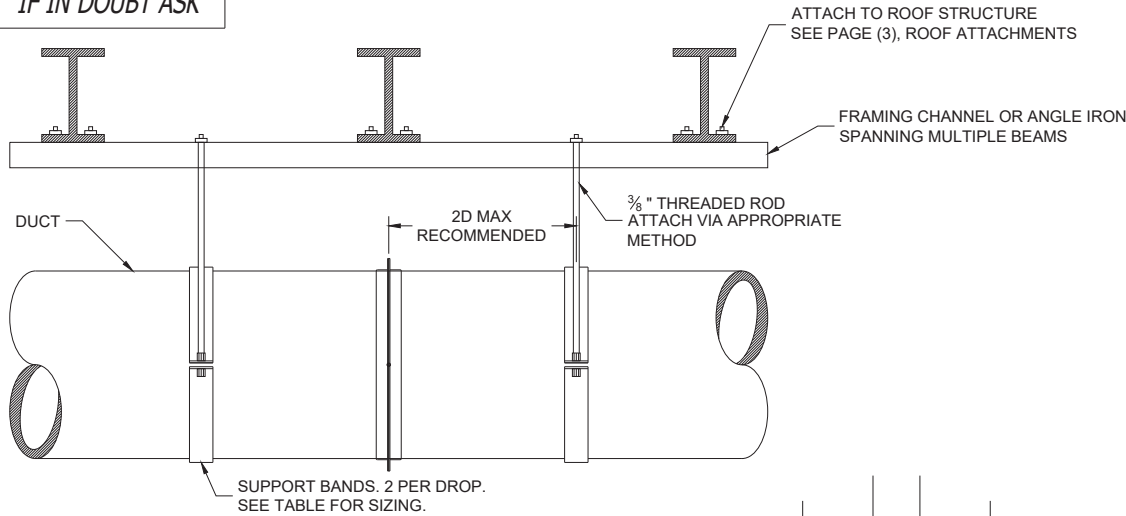

SUPPORT BANDS SHOULD BE USED ON ALL DUCT 26" DIAMETER AND LARGER

*3/8" THREADED ROD HAS A MAXIMUM LOAD OF 610 lbs.

*ONLY ONE UNSUPPORTED, UNWELDED VAN STONE DUCT SECTION CAN OCCUR BETWEEN SUPPORTS

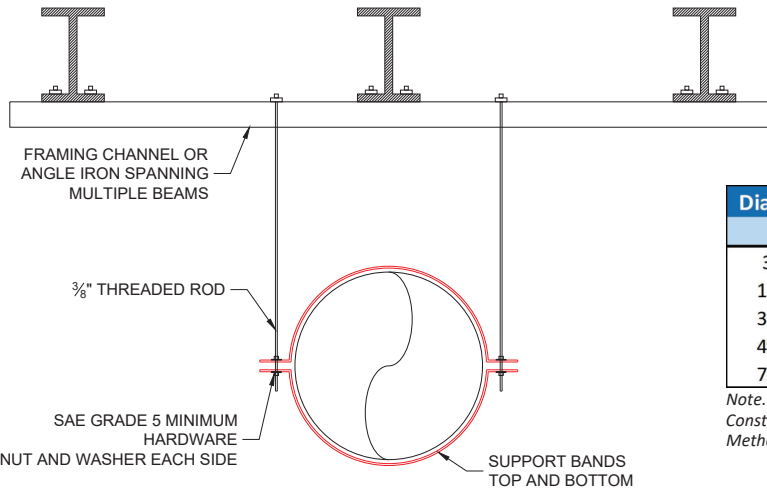

5865 McLaughlin Road
Mississauga, ON L5R 1B8
TEL: +1 (855) 925-1609
FAX: +1 (905) 366-2206

This drawing is confidential and the exclusive property of Nederman, Inc. No unauthorized use/copy or disclosure is to be made and it is to be returned whenever required.

TOLERANCE
ALL DIMS IN INCHES
.X ±.063
.XX ±.031
.XXX ±.015
ANGULAR ±1°
UNLESS OTHERWISE SPECIFIED

Material:

NAME	DATE	Rev:	Scale:
M. Davidson	2/27/2020	A	NTS
DRAWN:		Sheet #:	Size:
R. Williamson		4 of 8	A

Title:

Strap Hangers

Part Number:

Drawing Number:

DUCT_GUIDELINES

Table 5. Framing Channel Allowable Load

Unbraced Beam Span or Column Height	Concentric Load	1 5/8" x 1 5/8" x 12ga, I = 0.185 in ⁴ , S _x = 0.2042 in ³ , Weight = 1.90 lb/ft			
		Loads Resulting in a Maximum Bending Stress of 25 Ksi			
		Center Concentrated Load		Uniformly Distributed Load	
[in]	[lbs]	Load [lbs]	Deflection [lbs]	Load [in]	Deflection [lbs]
12	3952	1701	0.01	3401	0.01
24	3554	849	0.04	1698	0.06
36	2962	564	0.10	1129	0.13
48	2251	422	0.18	843	0.22
60	1603	336	0.28	671	0.35
72	1233	278	0.40	556	0.49
84	1003	236	0.53	473	0.67
96	847	205	0.69	410	0.87
108	734	181	0.87	361	1.09
120	548	161	1.06	321	1.32

Note. Reproduced from Round Industrial Duct Construction Standards, (3rd ed.). Table 13-6.1. Framing Channel – Load Tables.

Table 6. Angle Iron Allowable Load

Unbraced Beam Span or Column Height	Concentric Load	2" x 2" x 1/4", I = 0.348 in ⁴ , S _x = 0.247 in ³ , Weight = 3.190 lb/ft			
		Loads Resulting in a Maximum Bending Stress of 15 Ksi			
		Center Concentrated Load		Uniformly Distributed Load	
[in]	[lbs]	Load [lbs]	Deflection [lbs]	Load [in]	Deflection [lbs]
12		1233	–	2466	0.01
24		614	0.02	1228	0.02
36		406	0.04	813	0.05
48	Angle not efficient under compression loading	302	0.07	604	0.09
60		239	0.11	480	0.14
72		196	0.16	390	0.19
84		165	0.22	329	0.27
96		142	0.28	280	0.35
108		122	0.36	243	0.44
120		107	0.45	215	0.54

Note. Reproduced from Round Industrial Duct Construction Standards, (3rd ed.). Table 13-7.1. Angle Tables.

Design standards are based upon the following two reference manuals:

- SMACNA, (2013). Round Industrial Duct Construction Standards, (3rd ed.).
- ACGIH, (2019). Industrial Ventilation: A Manual of Recommended Practice for Design (30th ed.).

Table 4. Strap Hangers

Diameter	Width – W	Thickness – T
[in]	[in]	[in]
3 – 12	1 – 1/2	1/8
13 – 30	2	3/16
31 – 48	2 – 1/2	1/4
49 – 72	4	3/8
73 – 96	6	1/2

Note. Reproduced from Round Industrial Duct Construction Standards, (3rd ed.). Figure 13-4. Methods for Hanging Round Industrial Duct.

IF IN DOUBT ASK

Table 7.
Gripping Safe Working Load

Gripping Number	Allowable Load
[–]	[lbs]
#1	0 – 25
#2	25 – 100
#3	100 – 200
#4	200 – 495
#5	495 – 715

Table 8.
Gripping Selection by Pipe Diameter

Diameter	Spacing	
	10ft	15ft
3 – 12	#3	#4
13 – 21	#4	#5
22 – 24	#5	

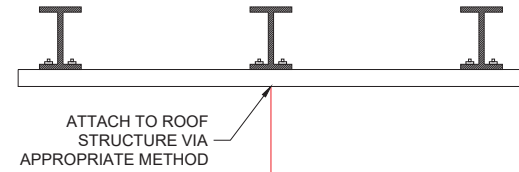

*GRIPPLES SHOULD ONLY BE USED ON PIPE SIZES UP TO AND INCLUDING 24" DIAMETER.

*GRIPPLE SPACING IS DETERMINED BASED UPON PIPE WEIGHT AND GRIPPLE SIZE.

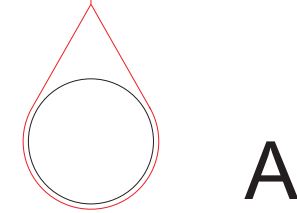

FOR STYLE "A", USE A SINGLE GRIPPLE SUSPENDED VERTICALLY FROM THE ROOF STRUCTURE.

FOR STYLE "B", USE TWO GRIPPLES HUNG AT AN ANGLE, NOT TO EXCEED 30° FROM VERTICAL.

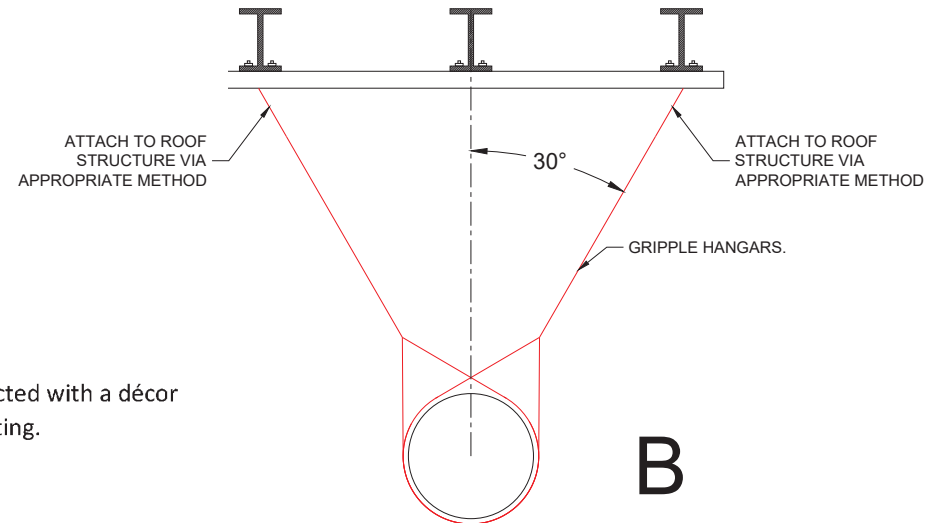

Gripping Hanger – Do's

- Ensure that the cable protrudes at least 3 inches from the Gripping housing.
- Use Gripping hangers for suspending static loads only.
- Use the hanger within its stated load range.
- Check that the self-locking fastener is fully engaged.
- Ensure all hangers are evenly loaded.
- Keep the hanger components clean.
- Follow the manufacturer's recommendations.
- Consider the effect of an angle, or forming in-line joints, has on the Safe Working Load.
- Follow health and safety guidelines and best practice recommendations in the workplace.
- Ensure appropriate PPE is worn when handling cable.

Gripping Hanger – Dont's

- Exceed the product's Safe Working Load.
- Use the hanger for lifting.
- Use the hanger for moving services.
- Splice together two Gripping hanger kits, or any other joining device.
- Walk on any suspended service.
- Use the self-locking fasteners on coated wire of any kind.
- Apply paint to the Gripping fastener. Ensure that the Gripping is in its final position and protected with a décor cover prior to applying any paint to the cable assembly. Do not move the gripple after painting.
- Apply lubricants or other coatings to the Gripping or cable.
- Use standard hangers in a chlorinated or humid atmosphere.
- Exceed an angle of 30° from vertical.
- Attempt to use the setting key when the suspension is under load.
- Reuse Gripping hangers; they are designed for permanent installations.

Design standards are based upon the following two reference manuals:

- SMACNA, (2013). *Round Industrial Duct Construction Standards*, (3rd ed.).
- ACGIH, (2019). *Industrial Ventilation: A Manual of Recommended Practice for Design* (30th ed.).



5865 McLaughlin Road
Mississauga, ON L5R 1B8
TEL: +1 (855) 925-1609
FAX: +1 (905) 366-2206

TOLERANCE
ALL DIMS IN INCHES

.X ±.063
.XX ±.031
.XXX ±.015
ANGULAR ±1°

UNLESS OTHERWISE SPECIFIED

Material:

	NAME	DATE
DRAWN:	M. Davidson	2/27/2020
CHECKED:	R. Williamson	

Rev:	Scale:
A	NTS
Sheet #:	Size:
5 of 8	A

Title:

Gripping Hangers

Part Number:

Drawing Number:

DUCT_GUIDELINES

This drawing is confidential and the exclusive property of Nederman, Inc. No unauthorized use/copy or disclosure is to be made and it is to be returned whenever required.

IF IN DOUBT ASK

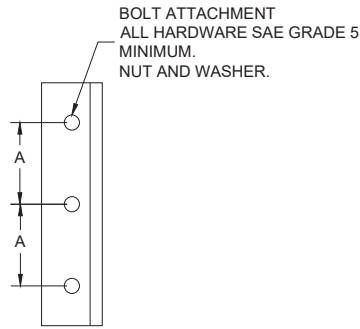
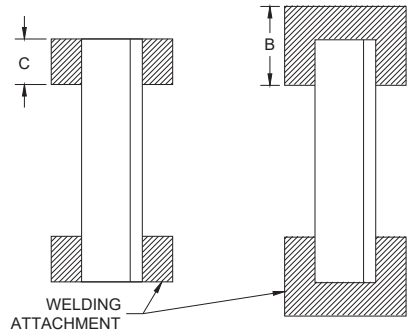

SEE PAGE (4), STRAP HANGERS

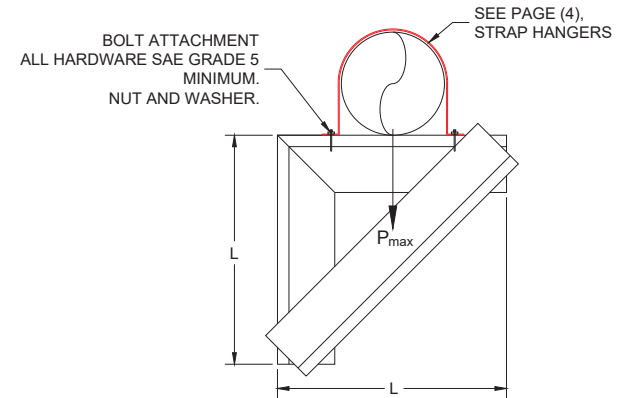
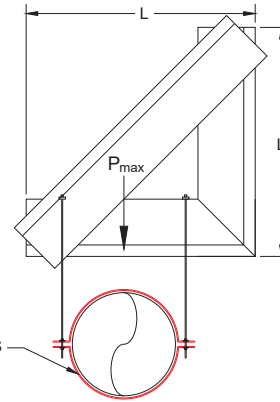

Table 9. Knee Brace Hanger

Angle Size [in]	L [in]	P _{max} [Kips]	Bolts			Welding	
			Number	Diameter [in]	A [in]	B [in]	C [in]
2 x 2 x 1/4	8	1.3	3	1/2	2.5		
2 x 2 x 1/4	12	1.5	3	1/2	4.0		
2 x 2 x 1/4	18	1.7	4	1/2	4.5		
2 x 2 x 1/4	24	1.7	4	1/2	6.5		
3 x 3 x 1/4	12	2	3	5/8	4.0		
3 x 3 x 1/4	18	2	3	5/8	7.0		
3 x 3 x 1/4	24	2	3	5/8	9.5		
3 x 3 x 1/4	30	2	4	5/8	8.0		2
3 x 3 x 1/4	36	2	4	5/8	11.0		2
3 x 3 x 1/4	42	2	5	5/8	9.0		2
4 x 4 x 3/8	12	4	3	7/8	4.0		
4 x 4 x 3/8	18	4	4	7/8	3.5		
4 x 4 x 3/8	24	4	4	7/8	6.0	1	
4 x 4 x 3/8	30	4	4	7/8	8.0	1	
4 x 4 x 3/8	36	4	4	7/8	10.0	1	
4 x 4 x 3/8	42	4	5	7/8	9.0	1	
4 x 4 x 3/8	48	4	5	7/8	10.0	1	
5 x 5 x 1/2	12	7	4	1	2.5		
5 x 5 x 1/2	18	7	4	1	4.0		
5 x 5 x 1/2	24	7	4	1	6.0		
5 x 5 x 1/2	30	7	4	1	8.0		
5 x 5 x 1/2	36	7	5	1	7.5		3
5 x 5 x 1/2	42	7	5	1	9.0		3
5 x 5 x 1/2	48	7	5	1	10.5		3
5 x 5 x 1/2	54	7	5	1	12.0		3
5 x 5 x 1/2	60	7	6	1	11.0		3

Note. Reproduced from Round Industrial Duct Construction Standards, (3rd ed.). Table 13-20. Knee Brace Hanger Capacity

Table 10. Knee Brace Support

Angle Size [in]	L [in]	P _{max} [Kips]	Bolts			Welding	
			Number	Diameter [in]	A [in]	B [in]	C [in]
2 x 2 x 1/4	8	1.9	3	1/2	2.5		
2 x 2 x 1/4	12	1.3	3	3/8	4.5		
2 x 2 x 1/4	18	0.9	3	3/8	7.0		
2-1/2 x 2-1/2 x 1/4	12	2	3	1/2	4.5		
2-1/2 x 2-1/2 x 1/4	14	1.3	3	1/2	7.0		
3 x 3 x 1/4	18	1.9	3	1/2	7.0		
3 x 3 x 1/4	24	1.5	3	1/2	10.0		2
3-1/2 x 3-1/2 x 1/4	18	2.6	4	1/2	4.5		
3-1/2 x 3-1/2 x 1/4	24	2	4	1/2	6.5		
4 x 4 x 3/8	18	5	4	5/8	4.5		
4 x 4 x 3/8	24	3.8	4	5/8	6.5		
4 x 4 x 3/8	30	3	4	1/2	8.5	1	
4 x 4 x 3/8	36	2.5	4	1/2	10.5	1	
5 x 5 x 1/2	24	8	5	3/4	5.0		
5 x 5 x 1/2	30	6.4	5	3/4	6.5		
5 x 5 x 1/2	36	5.3	5	5/8	8.0		
5 x 5 x 1/2	42	4.6	5	5/8	9.5		
6 x 6 x 1/2	30	9.2	6	3/4	5.0		
6 x 6 x 1/2	36	7.7	6	3/4	6.0		
6 x 6 x 1/2	42	6.7	6	5/8	7.5		
6 x 6 x 1/2	48	5.8	6	5/8	8.5		
6 x 6 x 1/2	54	5.1	6	5/8	9.5		
6 x 6 x 1/2	60	4.6	6	5/8	11.0		3

Note. Reproduced from Round Industrial Duct Construction Standards, (3rd ed.). Table 13-21. Knee Brace Support Capacity

Design standards are based upon the following two reference manuals:

- SMACNA, (2013). Round Industrial Duct Construction Standards, (3rd ed.).
- ACGIH, (2019). Industrial Ventilation: A Manual of Recommended Practice for Design (30th ed.).



5865 McLaughlin Road
Mississauga, ON L5R 1B8
TEL: +1 (855) 925-1609
FAX: +1 (905) 366-2206

TOLERANCE
ALL DIMS IN INCHES

.X ±.063
.XX ±.031
.XXX ±.015
ANGULAR ±1°

UNLESS OTHERWISE
SPECIFIED

Material:

	NAME	DATE	Rev:	Scale:
DRAWN:	M. Davidson	2/27/2020	A	NTS
CHECKED:	R. Williamson		Sheet #:	Size:
			6 of 8	A

Title:

Knee Braces

Part Number:

Drawing Number:

DUCT_GUIDELINES

This drawing is confidential and the exclusive property of Nederman, Inc. No unauthorized use/copy or disclosure is to be made and it is to be returned whenever required.

IF IN DOUBT ASK

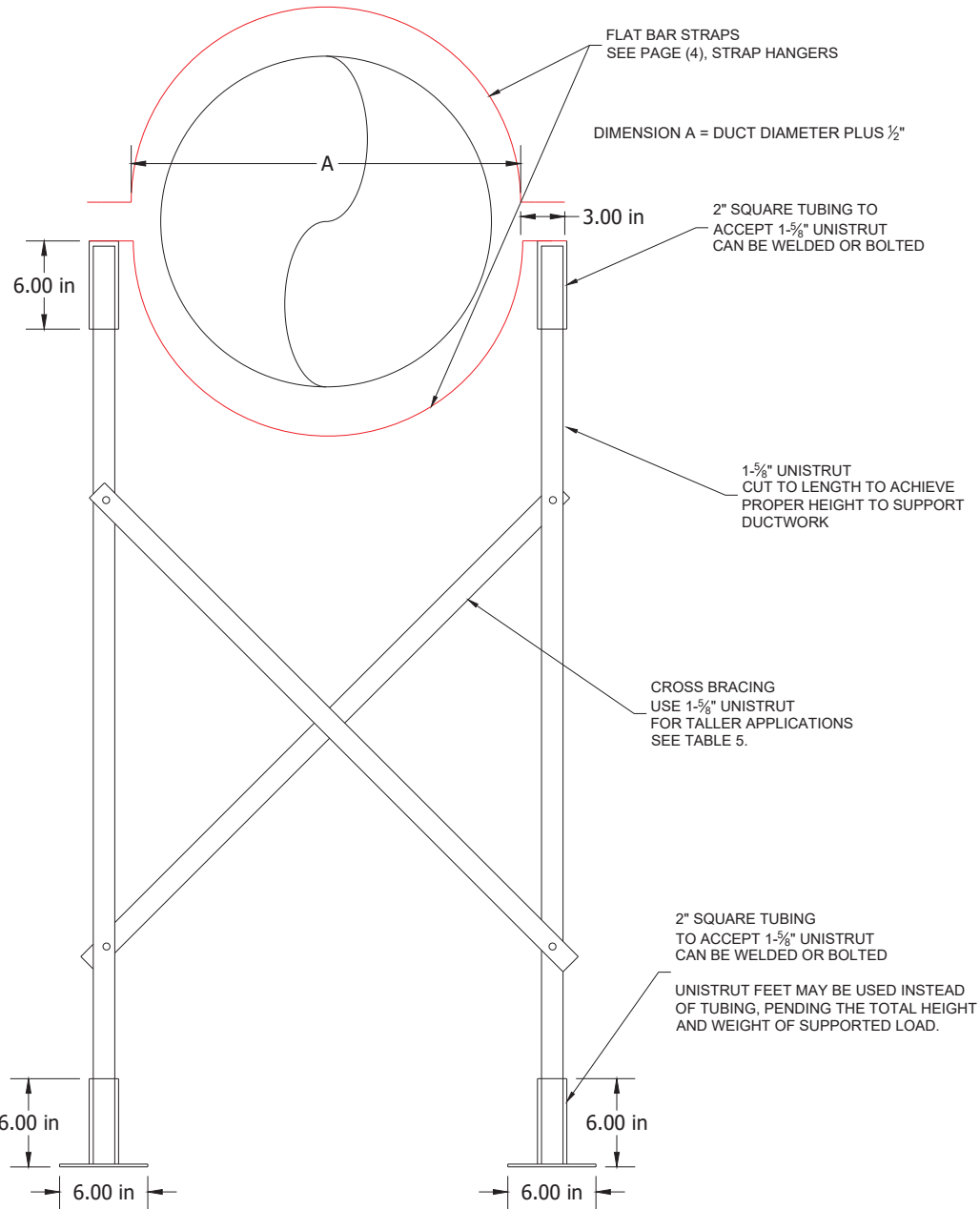

DUCT STAND FEET

MATERIAL: BASE 3/16" THICK BLACK IRON
PAINT BLACK

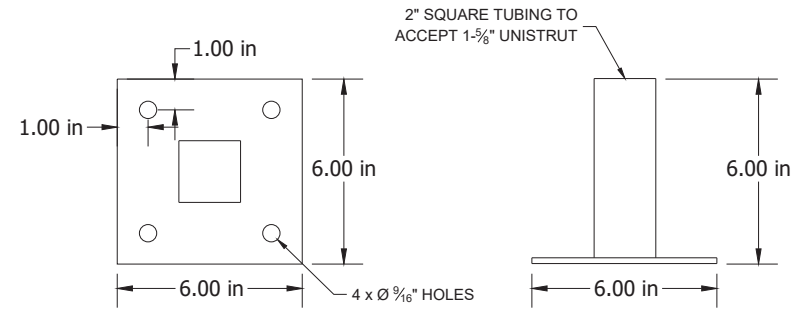

PLAN VIEW

SIDE VIEW

SCALE 2:1

Table 5. Framing Channel Allowable Load

Unbraced Beam Span or Column Height	Concentric Load	1 5/8" x 1 5/8" x 12ga, I = 0.185 in ⁴ , S _r = 0.2042 in ³ , Weight = 1.90 lb/ft			
		Column K = 1.0			
		Loads Resulting in a Maximum Bending Stress of 25 Ksi			
		Center Concentrated Load	Uniformly Distributed Load		
[in]	[lbs]	Load	Deflection	Load	Deflection
[in]	[lbs]	[lbs]	[lbs]	[in]	[lbs]
12	3952	1701	0.01	3401	0.01
24	3554	849	0.04	1698	0.06
36	2962	564	0.10	1129	0.13
48	2251	422	0.18	843	0.22
60	1603	336	0.28	671	0.35
72	1233	278	0.40	556	0.49
84	1003	236	0.53	473	0.67
96	847	205	0.69	410	0.87
108	734	181	0.87	361	1.09
120	548	161	1.06	321	1.32

Note: Reproduced from Round Industrial Duct Construction Standards, (3rd ed.). Table 13-6.1. Framing Channel – Load Tables.

Design standards are based upon the following two reference manuals:

- SMACNA, (2013). Round Industrial Duct Construction Standards, (3rd ed.).
- ACGIH, (2019). Industrial Ventilation: A Manual of Recommended Practice for Design (30th ed.).



5865 McLaughlin Road
Mississauga, ON L5R 1B8
TEL: +1 (855) 925-1609
FAX: +1 (905) 366-2206

TOLERANCE
ALL DIMS IN INCHES

.X	±.063
.XX	±.031
.XXX	±.015
ANGULAR	±1°

UNLESS OTHERWISE SPECIFIED

Material:

	NAME	DATE	Rev:	Scale:
DRAWN:	M. Davidson	2/27/2020	A	NTS
CHECKED:	R. Williamson		Sheet #:	Size:
			7 of 8	A

Title:

Exterior Support Stands

Part Number:

Drawing Number:

DUCT_GUIDELINES

This drawing is confidential and the exclusive property of Nederman, Inc. No unauthorized use/copy or disclosure is to be made and it is to be returned whenever required.

IF IN DOUBT ASK

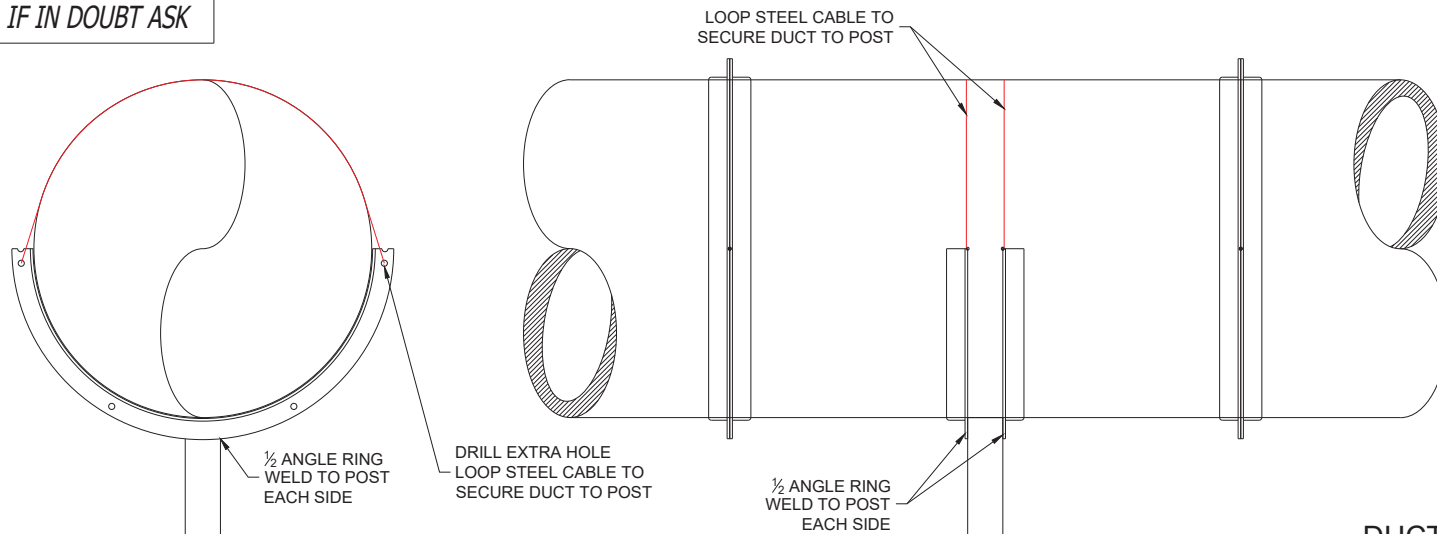

DUCT STAND FEET

SCALE 2:1

MATERIAL: BASE 3/16" THICK BLACK IRON PAINT BLACK

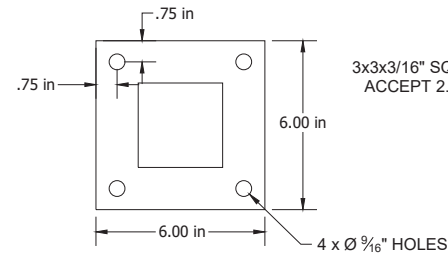

PLAN VIEW

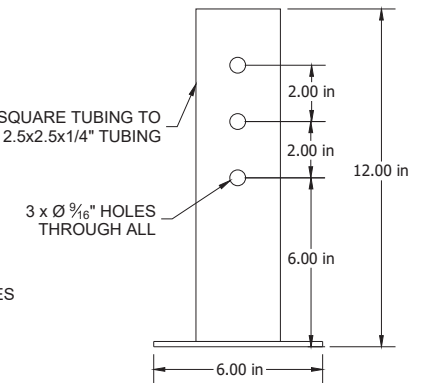

SIDE VIEW

2.5" SQUARE TUBE CUT TO LENGTH TO ACHIEVE PROPER HEIGHT TO SUPPORT DUCTWORK PAINT BLACK.

3" SQUARE TUBING TO ACCEPT 2.5" SQUARE TUBING CAN BE WELDED OR BOLTED

UNISTRUT FEET MAY BE USED INSTEAD OF TUBING, PENDING THE TOTAL HEIGHT AND WEIGHT OF SUPPORTED LOAD.

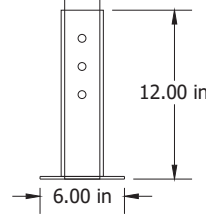
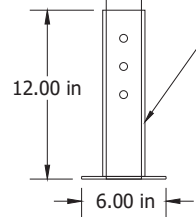

5865 McLaughlin Road
Mississauga, ON L5R 1B8
TEL: +1 (855) 925-1609
FAX: +1 (905) 366-2206

TOLERANCE
ALL DIMS IN INCHES

.X ±.063
.XX ±.031
.XXX ±.015
ANGULAR ±1°

UNLESS OTHERWISE SPECIFIED

Material:

	NAME	DATE	Rev:	Scale:
DRAWN:	M. Davidson	2/27/2020	A	NTS
CHECKED:	R. Williamson		Sheet #:	Size:
			8 of 8	A

Title:

Exterior Support Posts

Part Number:

Drawing Number:

DUCT_GUIDELINES

This drawing is confidential and the exclusive property of Nederman, Inc. No unauthorized use/copy or disclosure is to be made and it is to be returned whenever required.