

GENERAL RENOVATION NOTES

- MAINTAIN MINIMUM 3700mm (12'-0") LATERAL DISTANCE BETWEEN SANITARY VENTS AND ALL AIR INTAKE/EXHAUST OPENINGS.
- MAINTAIN MINIMUM 3000mm (10'-0") LATERAL DISTANCE BETWEEN PRV, FUEL FIRED APPLIANCE, AND/OR EXHAUST VENTS AND ALL AIR INTAKE/EXHAUST OPENINGS.
- ALL EQUIPMENT SHALL BE MINIMUM 3.0M FROM EDGE OF ROOF.

The contractor shall verify all dimensions and report all errors and discrepancies to the Consultant before commencement of the work. The drawings show general arrangement of services. Follow as closely as actual building construction will permit. Obtain approval for relocation of service from Consultant before commencement of the work. The drawings do not indicate all offsets fitting and accessories which may be required. Provide the same to meet the required conditions. Drawings and specifications, etc., prepared and issued by the consultant are the property of the consultant and must be returned at the completion of the project. These documents are not to be duplicated or copied without the consent of the Consultant. Do not scale this drawing. © 2026 DEI Consulting Engineers Inc.

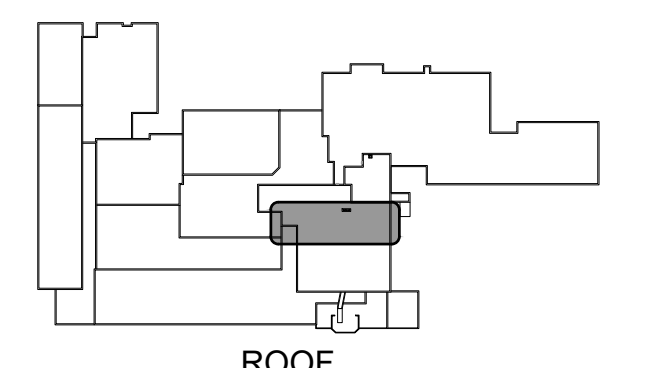

ROOF KEY PLAN

ROOF PART PLAN - RENOVATION
SCALE: 1:100

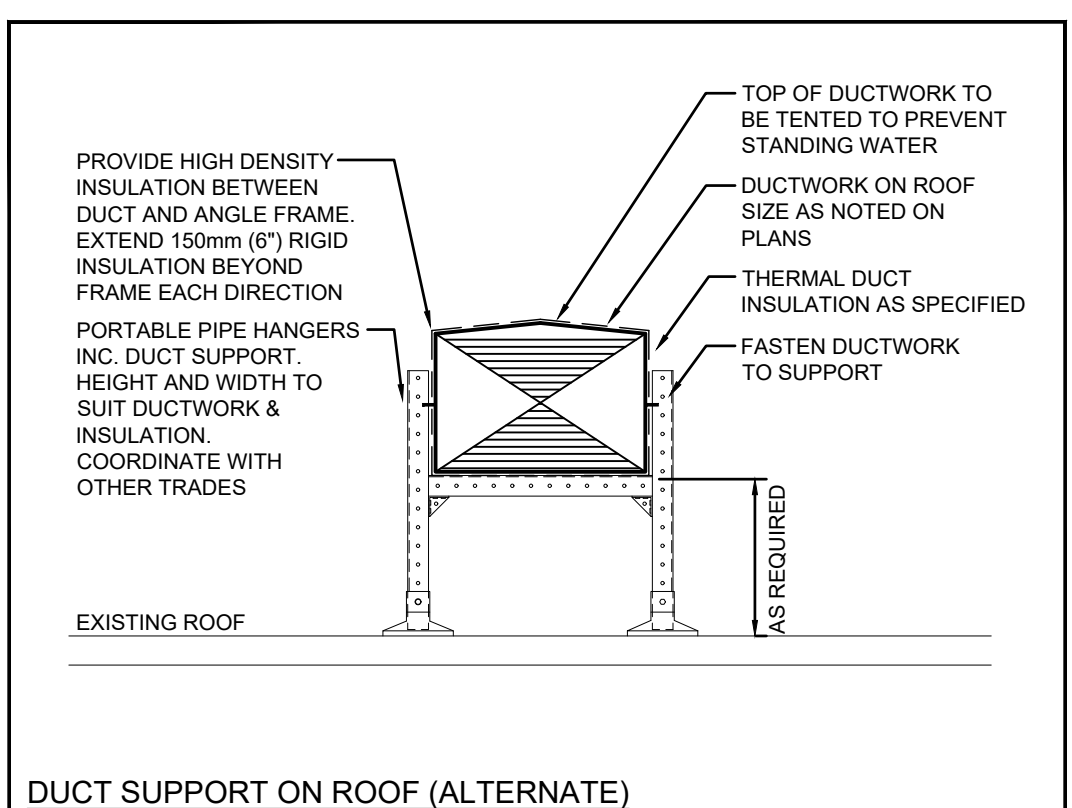
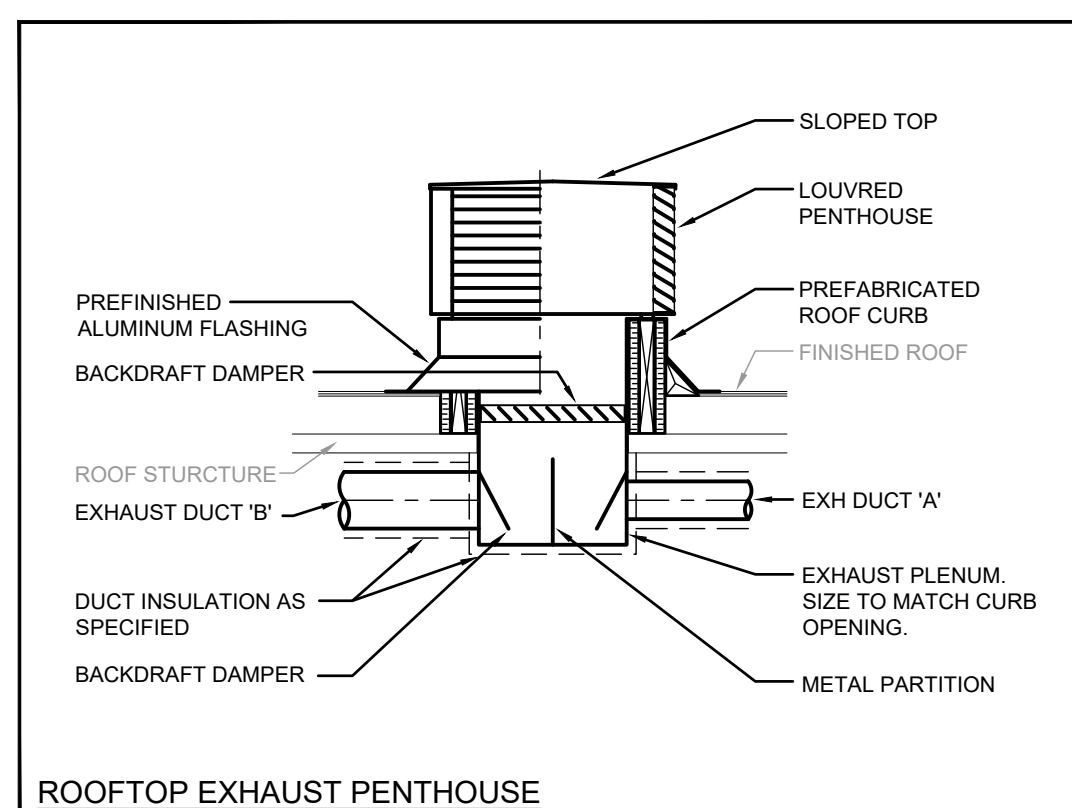
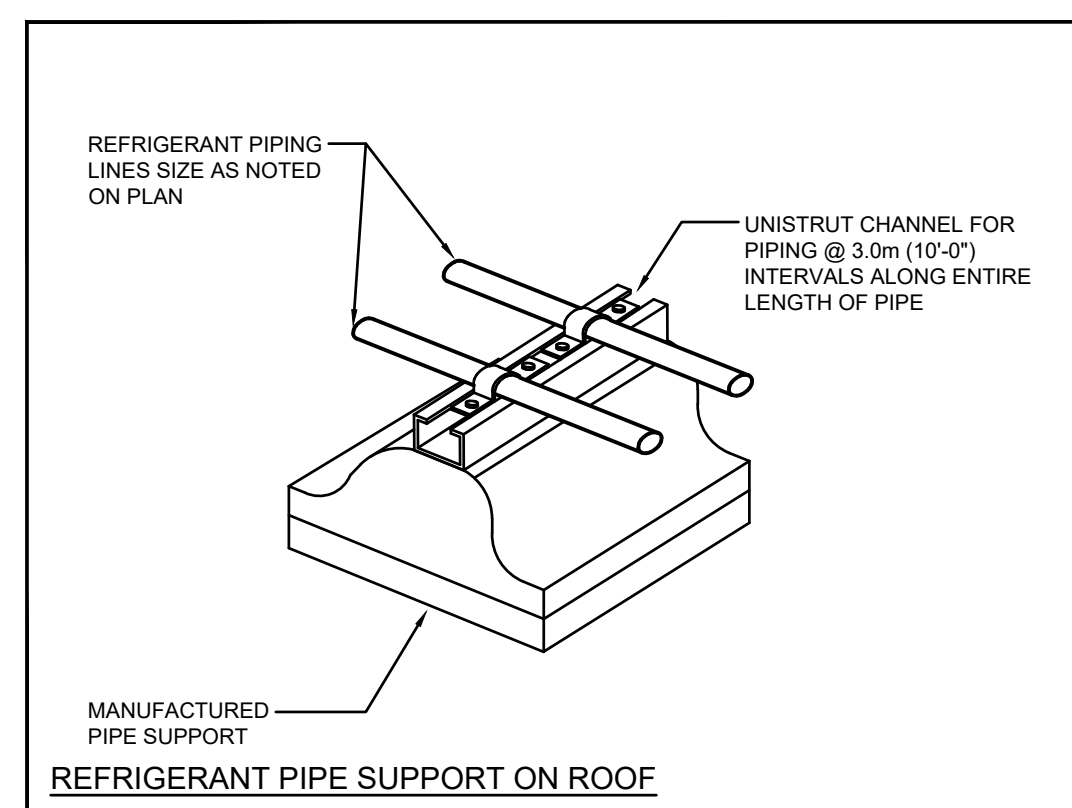
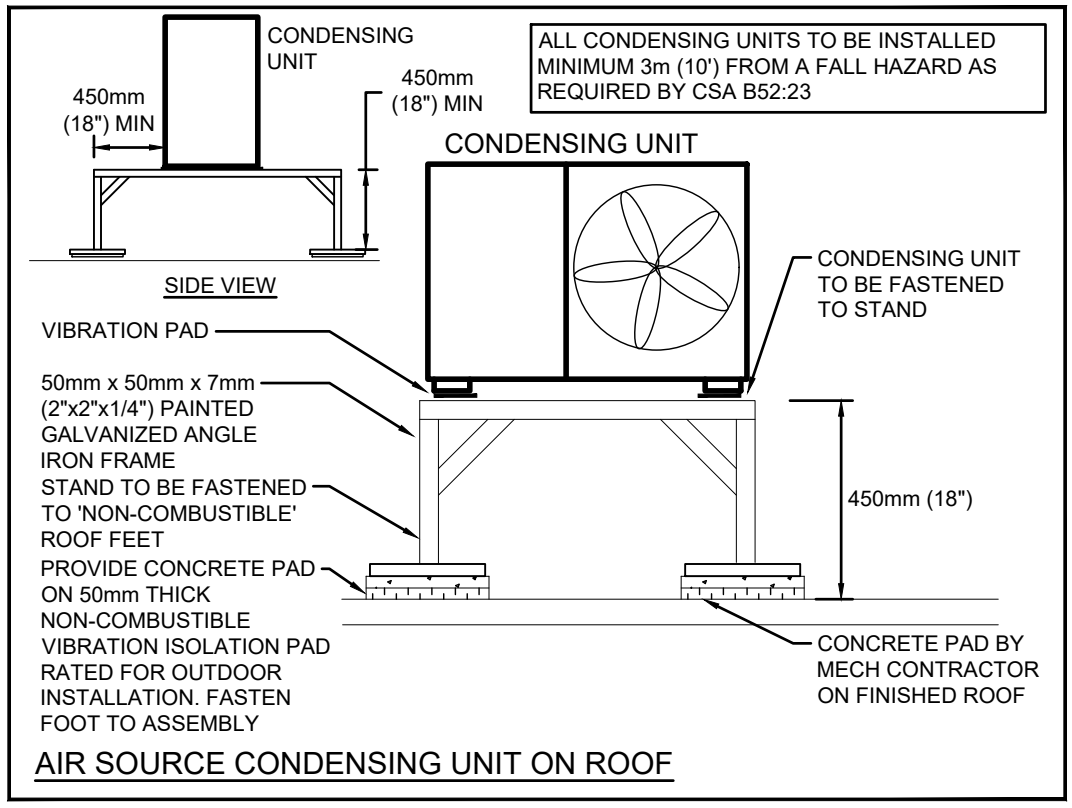
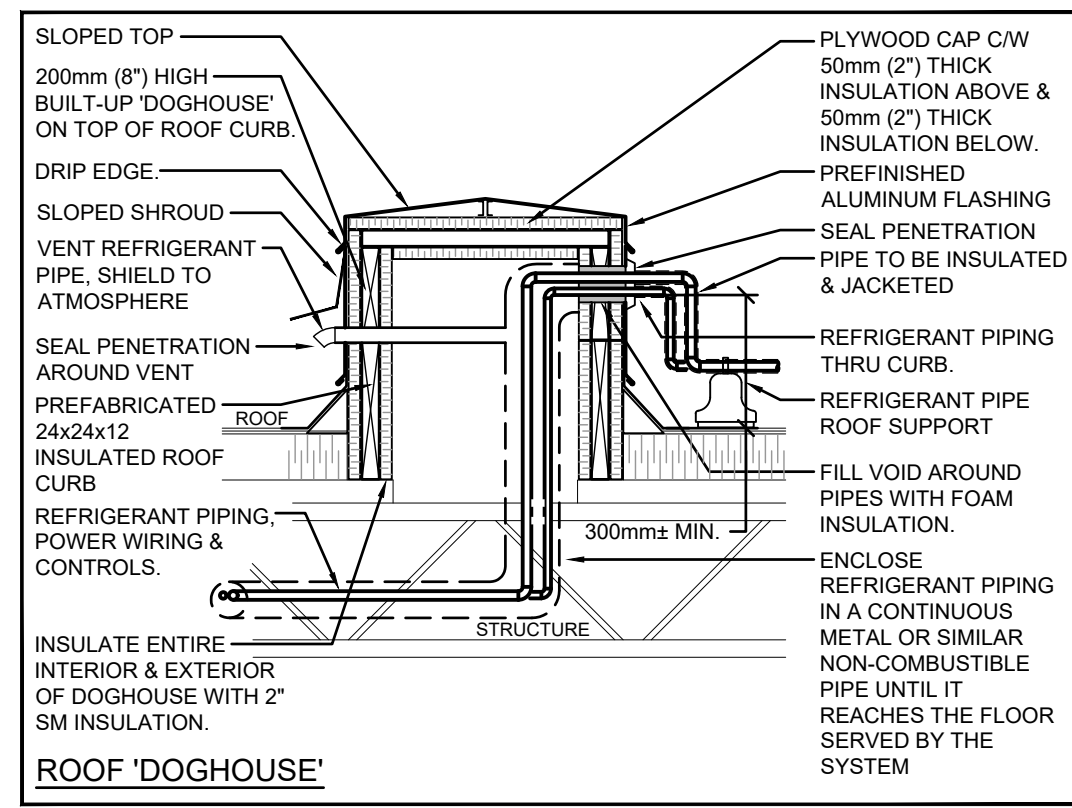
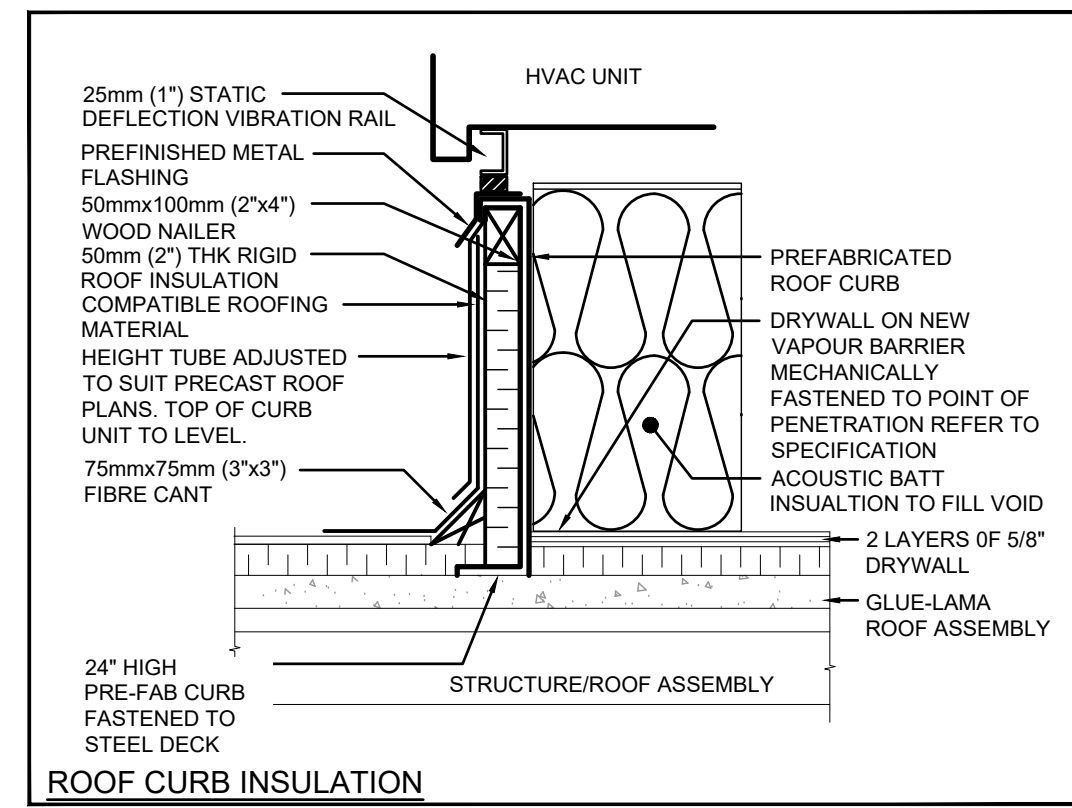
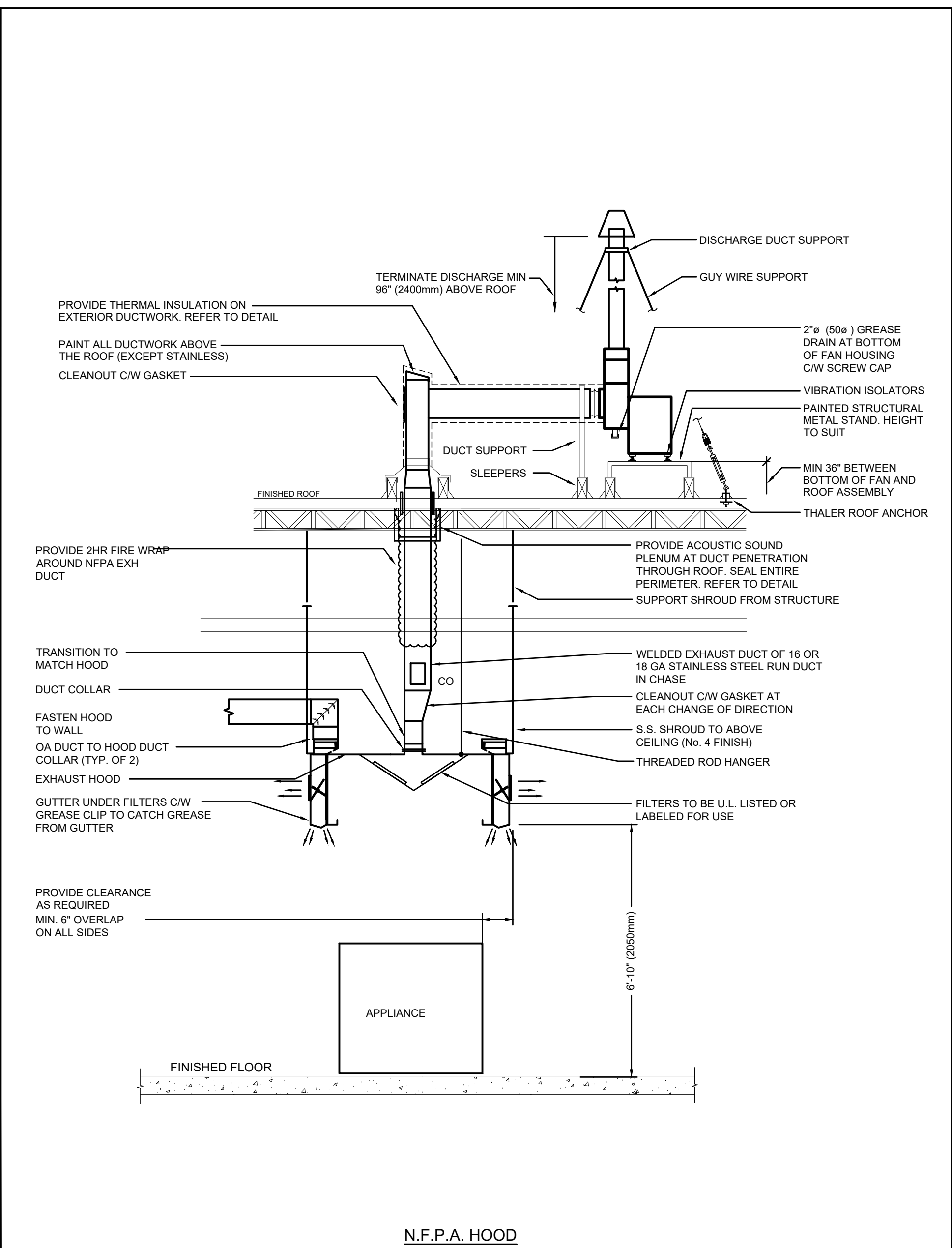
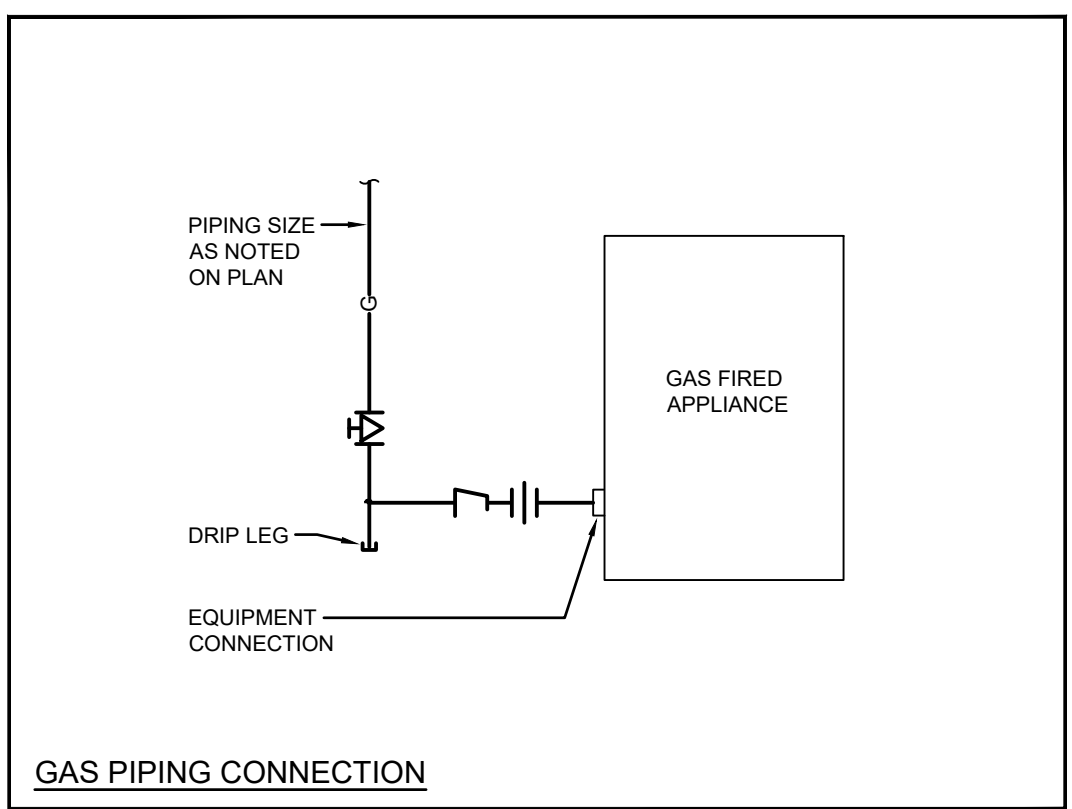
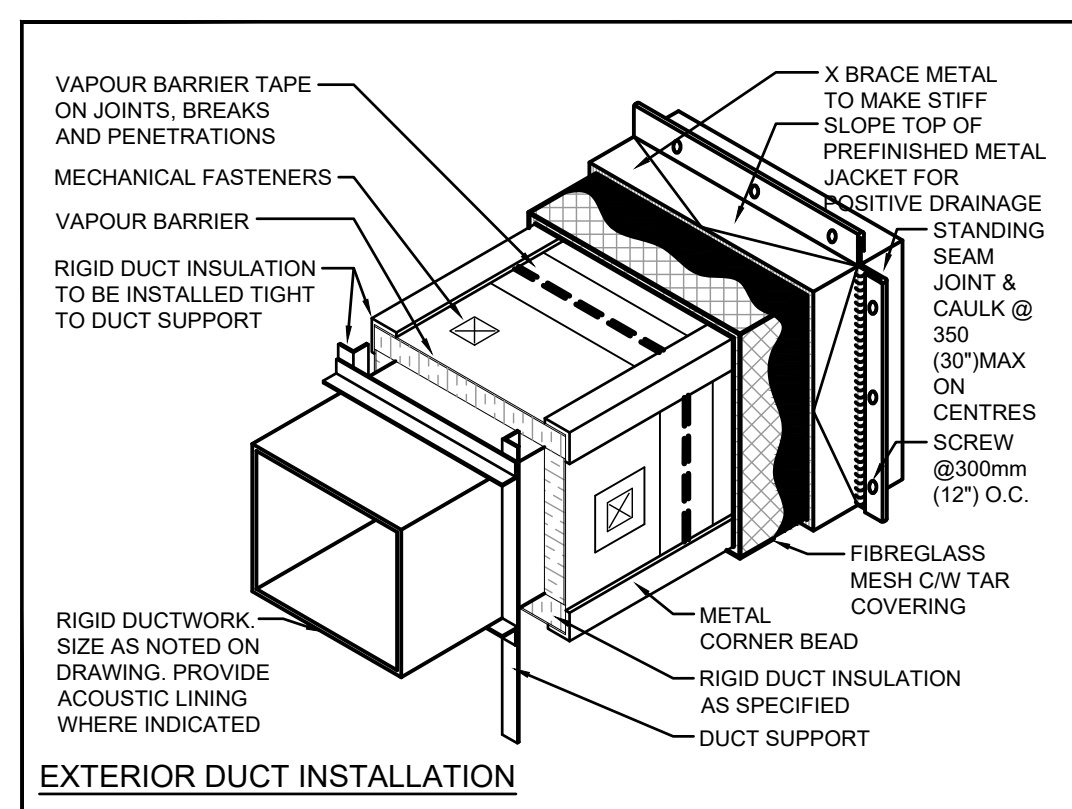

DEI
Consulting Engineers
MECHANICAL | ELECTRICAL | AQUATIC

55 Northland Road, Waterloo, ON N2V 1Y8
Phone: 519-725-3555
Website: deiconsultants.ca
Project Number: 25452

NOTE: THIS DRAWING IS NOT TO BE SCALED. THE CONTRACTOR IS RESPONSIBLE FOR THE VERIFICATION OF ALL SITE DIMENSIONS AND FOR NOTIFYING THE ARCHITECT OF ANY SITE CONDITIONS AND SITE MEASUREMENTS THAT ARE NOT CONSISTENT WITH THE DRAWINGS.

No.	Revision	Date

No.	Issue	Date
1	Issued for Permit & Tender	2026.04.02

project
WRDSB PRESTON HIGH SCHOOL RENOVATIONS

WATERLOO REGION DISTRICT SCHOOL BOARD
550 ROSE ST. CAMBRIDGE, ON N3H 2E6

drawing
ROOF PART PLAN - RENOVATION, AND DETAILS

drawing scale
AS NOTED

ward99 project number
25023 - WRDSB PRESTON FAMILY STUDIES AND CLASSROOM

ward99 architects | drawing no.

Wa RD₉₉

M4.5

ward99 architects inc.
7500 Highway 27, Unit 27B
Vaughan ON L4H 0J2
info@ward99architects.com
416-513-9800 www.ward99architects.com

