

# **SPECIFICATION**

UNIVERSITY OF TORONTO SCARBOROUGH

Interior Renovation of SY Level 2 Bio Science Lab

UTSC 2025-20

**DATE:**

March 19, 2026

ISSUED FOR TENDER

## Index

26 00 01.00	Electrical – Project Overview	2
26 01 00.00	Operating and Maintenance Instructions	3
26 05 01.00	General Instructions for Electrical Sections	8
26 05 03.00	Record Drawings	1
26 05 04.00	Submittals and Shop Drawings	1
26 05 21.00	Wires and Cables (0-1000V)	4
26 05 26.00	Grounding and Bonding	2
26 05 29.00	Hangers and Supports	2
26 05 31.00	Splitters, Junction, Pull Boxes and Cabinets	2
26 05 32.00	Outlet Boxes, Conduit Boxes and Fittings	2
26 05 34.00	Conduits, Conduit Fasteners and Fittings	4
26 05 53.00	Identification	3
26 05 83.00	Sleeves	2
26 05 88.00	Cutting and Patching	1
26 24 16.00	Distribution Panel Boards	2
26 27 02.00	Surge Protective Device	5
26 27 19.00	Multi-Outlet Assemblies	2
26 27 26.00	Wiring Devices	3
26 28 14.00	Fuses – Low Voltage	2
26 28 21.00	Moulded Case Circuit Breakers	2
26 50 00.00	Lighting	5

- 
1. General
    - 1.1. WORK INCLUDED
      - 1.1.1. Refer to Section 26 05 01.00 – GENERAL INSTRUCTIONS FOR ELECTRICAL SECTIONS.
      - 1.1.2. General conditions shall conform to the Canadian Construction standard contract document CCDC-2 and the general instructions as indicated in Section 26 05 01.00 – GENERAL INSTRUCTIONS FOR ELECTRICAL SECTIONS.
      - 1.1.3. Conform to all requirements of Project Manual.
    - 1.2. EXISTING CONDITIONS
      - 1.2.1. Visit the site and examine the existing conditions affecting the work of this Division.
      - 1.2.2. No claim for extra payment shall be made for extra work made necessary by circumstances encountered due to conditions which were visible upon, or reasonably inferable from an examination of the site prior to submission of the Bid.
      - 1.2.3. Be aware that there may be asbestos fibres present in various finishes or on various surfaces, in certain areas of the building. Arrange work so as not to disrupt these materials, or take full and necessary means to protect all personnel from contact with them, in a way to be approved by the University. Include all costs associated with any remedial work, with the Bid.
    - 1.3. DEMOLITION
      - 1.3.1. The demolition of any existing electrical equipment and wiring in the building, unless shown on the drawings to remain, shall be carried out by this Contractor.
      - 1.3.2. Make safe and disconnect all power and systems, as and when, and to the extent required to facilitate with the demolition.
      - 1.3.3. Ensure that all electrical, life safety services, and services for existing equipment, in areas outside the areas of this work, that are required to remain in service, shall do so.
      - 1.3.4. Relocate any electrical feeders or equipment that are required to remain in service, that are secured to existing walls, floors or ceilings to be demolished or that are buried and required to be excavated for new work.
      - 1.3.5. Remove and replace any electrical equipment on walls or ceilings that will be demolished and rebuilt.
      - 1.3.6. When deleting and/or making safe existing electrical work, ensure that it includes all wiring back to the associated panelboard or control panel.
      - 1.3.7. Disconnect and remove existing light fixtures, devices, outlets, etc. which are not to be reused. Such items shall be cartoned and turned over to the University at a place designated by the University. Cut back and cap unused raceway and outlets and remove unused wiring back to panelboard in an approved manner.
      - 1.3.8. Ensure that all existing equipment which is to be reused and/or relocated is thoroughly inspected and refurbished to ensure correct operation when put back into service and to meet the requirements of the local authorities having jurisdiction.

- 1.3.9. All existing electrical equipment which is no longer required shall be removed and disposed of, off site.
- 1.3.10. Be responsible and pay for any damage to the base building incurred by work of this Division, or repair to the satisfaction of the University.
- 1.3.11. Carry out the work with a minimum of noise, dust and disturbance.
- 1.3.12. Provide tools and clean up equipment. Obtain the University's permission for the use of electrical, plumbing or drainage outlets.
- 1.3.13. Provide daily clean-up and proper disposal of debris generated by daily operations. On completion of the work, all tools, surplus materials and waste materials shall be removed and the premises left in a clean, perfect condition.

2. Products

2.1. NOT USED

3. Execution

3.1. NOT USED

END OF SECTION 26 00 01.00

- 
1. General
    - 1.1. WORK INCLUDED
      - 1.1.1. Conform to Section 26 01 00.00 – GENERAL INSTRUCTIONS FOR ELECTRICAL SECTIONS.
      - 1.1.2. Comply with all requirements of Section 26 05 03.00 – RECORD DRAWINGS.
      - 1.1.3. Comply with all requirements of Section 26 05 04.00 – SHOP DRAWINGS.
  2. Products
    - 2.1. NOT USED
  3. Execution
    - 3.1. REQUIREMENTS FOR MANUALS
      - 3.1.1. A minimum of two copies of complete and approved operating and maintenance instructions for all electrical equipment and systems shall be supplied before substantial completion. Provide additional copies if required under the General Requirements. In addition to the three copies of manuals, the contractor to provide a manual in a searchable PDF format on CD. As-Built Drawings to be included on the CD.
      - 3.1.2. The contractor to identify the cost of Record Drawings and the Operation and Maintenance Manuals as a separate line item on their progress draw. The values to be broken out can be found in Section 26 05 03 – Record Drawings. The project will remain incomplete and no money will be released until the final versions, both hard and electronic, of the drawings and manuals are received and reviewed without comments.
      - 3.1.3. Binders shall be three-ring, hard-cover, loose-leaf type and identified on the binding edges as “Maintenance Instructions and Data Book”, for “(Project Name)”.
      - 3.1.4. Terminology used in all the sections shall be consistent.
      - 3.1.5. Volume One shall contain the master index of all systems, the name of the Contractor, Electrical Subcontractors and the date of substantial performance for the Contract.
      - 3.1.6. Volume One shall contain a section with all necessary warranty information.
      - 3.1.7. Each binder shall have a complete index for all volumes.
      - 3.1.8. Each binder shall be no more than half filled.
      - 3.1.9. There shall be a separate section for all materials used on the project which fall under the WHMIS legislation. There shall be a hazard data sheet for each of the materials.
      - 3.1.10. There shall be a separate section for all Insurance Certificates, Test Certificates, Verification Forms and Test Forms.
      - 3.1.11. All relevant information relating to a system or product shall be contained within one binder.
      - 3.1.12. The manual sections shall follow the specification sections.

3.1.13. Any diagrams, installation drawings, single line diagrams charts, etc. shall be mechanically reduced while maintaining full legibility to standard page size. If this cannot be achieved they shall be carefully folded and contained within a clear plastic wallet within the manual.

### 3.2. DATA FOR MANUALS

3.2.1. Equipment data shall contain:

- .1 Operating instructions.
- .2 Operating conditions such as temperature and pressure.
- .3 Location of equipment.
- .4 Maintenance instructions and schedules for one year routine.
- .5 Recommended list of spare parts.
- .6 Maintenance schedule.
- .7 A trouble shooting table showing where to look for problems under various conditions of malfunction.
- .8 All wiring diagrams.
- .9 Equipment operating curves.
- .10 Equipment nameplate data and serial numbers.

3.2.2. System data shall contain:

- .1 A listing of all systems.
- .2 All panel, mcc and fire alarm schedules and locations.
- .3 Equipment name tags.
- .4 Cleaning, maintaining and preserving instructions for all material, products and surfaces. Include warnings of harmful cleaning, maintaining and preserving practices.

3.2.3. Sub-Contractor manuals are required for:

- .1 Switchboards and power distribution systems.
- .2 Lighting systems.
- .3 Emergency power systems.
- .4 Fire alarm systems.

3.2.4. As-Built documentation shall contain:

- .1 Reviewed As-Built Shop Drawings.
- .2 As-Built Construction Drawings.
- .3 Originals of test forms.
- .4 Originals of test certificates.

### 3.3. OPERATING INSTRUCTIONS

3.3.1. Instruct the Owner's representative in all aspects of the operation and maintenance of systems and equipment.

3.3.2. Arrange for and pay for the services of engineers and other manufacturers representatives required for instruction on the systems and the equipment as requested by the Engineer's Representative and/or the Owner.

- 3.3.3. At the time of final review, provide a sheet for each system and piece of equipment showing the date instructions were given. Each sheet shall show the duration of instruction, name of persons receiving instruction, other persons present (manufacturer's representative, Engineer's Representative, etc.), system or equipment involved and signature of the Owner's staff stating that they understood the system installation, operating and maintenance requirements. This information shall be inserted in the manuals after all instructions have been completed.
- 3.3.4. Review information with the Owner's representative to ensure that all information required has been provided.

END OF SECTION 26 01 00.00

- 
1. General
    - 1.1. WORK INCLUDED
      - 1.1.1. Conform to the requirements of the Project Manual, which applies to and forms part of all sections of the work.
    - 1.2. DESCRIPTION OF SECTION
      - 1.2.1. The specification is divided into sections of work and a section may consist of the work of more than one subcontractor. The responsibility as to which electrical subcontractor provides labour, materials, equipment and services required to complete the work rests solely with the Electrical Contractor.
    - 1.3. SECTIONS AFFECTED
      - 1.3.1. These instructions apply to and form a part of all electrical sections.
    - 1.4. SCOPE
      - 1.4.1. Provide all labour, materials, equipment and services to complete the work of the electrical contractor as further specified and as shown on the drawings.
      - 1.4.2. Where a discrepancy occurs between the specification and the drawings, issue an RFI to clarify the matter. If the matter is not brought forth by the contractor, the higher cost of the two options is included in the project. No additional costs will be entertained.
    - 1.5. REGULATIONS
      - 1.5.1. All work shall be performed in accordance with the latest codes, rules, regulations, by-laws and requirements of all authorities having jurisdiction.
      - 1.5.2. Do complete installation in accordance with current edition of the Ontario Electrical Safety Code except where specified otherwise.
      - 1.5.3. These specifications are supplementary to the requirements above.
      - 1.5.4. Drawings and specifications should not conflict with the above regulations but where there are apparent discrepancies the contractor shall notify the University's Representative.
    - 1.6. PERMITS, FEES REVIEW
      - 1.6.1. Make submissions to obtain all permits. Include for and pay for all fees and arrange for all reviews required for the work of this division.
      - 1.6.2. If required by code, plans and specifications have been previously submitted to the Electrical Safety Authority as per Rule 2-010.
      - 1.6.3. Furnish certificates of Acceptance from the electrical review department and authorities having jurisdiction and include them in the Operation and Maintenance manual.
    - 1.7. VOLTAGE RATINGS
      - 1.7.1. Operating voltages are as specified in CAN3-C235-83.

- 
- 1.7.2. Motors, electric heating, control and distribution devices and equipment are to operate satisfactorily at 60 Hz within operating limits established by the above standard.
- 1.8. VOLTAGE RATINGS
- 1.8.1. Unless indicated otherwise on the Electrical Drawings, Electrical Contractor will be responsible for the supply and installation of the following:
- .1 Line and load side wiring for starters.
  - .2 Line and load side wiring to variable speed drives.
  - .3 Provisions of disconnects to all mechanical equipment.
  - .4 All power wiring (120V & above) to all mechanical equipment.
  - .5 All motorized damper power connections (120V & above).
  - .6 Fire alarm devices.
  - .7 Wiring to electric space heaters.
- 1.8.2. Mechanical Divisions will be responsible for the supply and installation of the following:
- .1 Starters
  - .2 Electric ramp and sidewalk heating cables and controls.
  - .3 All variable speed drives and control wiring to starters.
  - .4 Pipe tracing and related controls.
  - .5 Electric hot water heaters.
  - .6 All electrical heaters including baseboard heaters, cabinet heaters, force flow heaters and radiant heaters.
  - .7 All interposing relays, relays, contactors and 120V control devices.
  - .8 All 120V and low voltage control wiring and conduits.
- 1.8.3. Determine exact location of starters, motors and line voltage controls based on the mechanical drawings to coordinate with the locations of all equipment to ensure the required clearances are maintained. If no wall location is suitable for the motor starters then mount the starters on a plywood backboard on unistrut supports near the respective equipment to meet the applicable code requirements for motor isolation switches. If a motor or piece of equipment is listed on one of the starter schedules but is not shown on the floor plans, the contractor is to reference the mechanical drawings for the location of the respective piece of equipment. No additional costs will be entertained.
- 1.8.4. Should the mechanical contractor change any of the motor or equipment sizes from those identified on the mechanical schedules and drawings at any stage of the project to aide their installation, the mechanical contractor will incur all extra electrical costs to revise the electrical feeders, breakers, starters and equipment to supply power to the revised piece of equipment.
- 1.9. PLYWOOD BACKBOARDS, EQUIPMENT MOUNTING, & HOUSEKEEPING PADS
- 1.9.1. Provide fire rated plywood backboards as shown on the drawings and mount where all communication equipment is to be wall mounted. Plywood is to be 21 mm (13/16 in.), be urea- formaldehyde (UF) free and be either Forest Stewardship Council (FSC), Sustainable Forestry Initiative (SFI) or CSA Z809-08 certified. Plywood to be either fire rated with the appropriate label displayed once installed or coated with fire retardant paint. All Certification not to be painted

- 
- 1.9.2. Provide steel re-enforced concrete housekeeping pads under all floor mounted electrical equipment and where noted on the drawings. All housekeeping pads to be a minimum of 100mm (4") high above finished floor and shall not extend beyond 50mm (2") beyond the electrical equipment unless shown otherwise on the drawings.
- 1.10. FINISHES
- 1.10.1. Metal enclosure surfaces are to be finished by the application of rust resistant primer on both the inside and outside, with at least two coats of enamel.
- 1.10.2. Clean and touch up all surfaces of equipment scratched or marred during shipment or installation. Match the original paint.
- 1.10.3. Clean and prime exposed non-galvanized hangers, racks and fastenings to prevent rusting.
- 1.10.4. All paints, coatings, sealants and adhesives shall meet the VOC limits.
- 1.11. SAFETY
- 1.11.1. Protect exposed live equipment during construction for personnel safety.
- 1.11.2. Shield and mark all live parts "LIVE 120 VOLTS", or with appropriate voltage in English.
- 1.11.3. Arrange for the installation of temporary doors for rooms containing electrical distribution equipment. Keep these doors locked except when under direct supervision of an electrician.
- 1.12. FIRE STOPPING
- 1.12.1. Provide fire stopping in accordance with front end documents and as describe herein. Contractor to coordinate fire stopping with Prime Contractor. All paints, coatings, sealants and adhesives shall meet the VOC limits.
- 1.12.2. Fire stopping and smoke seal systems: in accordance with CAN4 S115 M85.
- .1 Asbestos free materials and systems capable of maintaining an effective barrier against flame, smoke and gases in compliance with requirements of CAN4 S115 M85 and not to exceed opening sizes for which they are intended.
  - .2 Fire stop system rating for service penetrations: to suit Ontario Building Code 1997, 3.1.9.1 Fire Stopping of Service Penetrations.
  - .3 Fire stop system rating for sealing junction of rated walls to rated floors and ceilings: to suit Ontario Building Code.
- 1.12.3. Service penetration assemblies: certified by ULC in accordance with CAN4 S115 M85 and listed in ULC Guide No. 40 U19.
- 1.12.4. Service penetration fire stop components: certified by ULC in accordance with CAN4 S115 M85 and listed in ULC Guide No. 40 U19.13 and ULC Guide No. 40 U19.15 under the Label Service of ULC.
- 1.12.5. Fire resistance rating of installed fire stopping assembly not less than the fire resistance rating of surrounding floor and wall assembly, and in accordance with Ontario Building Code.
- 1.12.6. Fire stopping and smoke seals at openings intended for ease of re entry such as cables: elastomeric seal; do not use cementitious or rigid seal at such locations.
- 1.12.7. Fire stopping and smoke seals at openings around penetrations for pipes, ductwork and other mechanical items requiring sound and vibration control: elastomeric seal; do not use a cementitious or rigid seal at such locations.

- 
- 1.12.8. Primers: to manufacturer's recommendation for specific material, substrate, and end use.
- 1.12.9. Water (if applicable): potable, clean and free from injurious amounts of deleterious substances.
- 1.12.10. Damming and backup materials, supports and anchoring devices: to manufacturer's recommendations, and in accordance with tested assembly being installed as acceptable to authorities having jurisdiction.
- 1.12.11. Sealants for vertical joints: non sagging.
- 1.12.12. Colour: if range available to University's Representative's choice of standard colours, generally to match background colour where visible in finished spaces.
- 1.12.13. Through non-fire or non-smoke separations or where waterproof membrane is field applied, where pipes are insulated, sleeves shall be sized to accommodate the insulation and vapour barrier.
- 1.12.14. Where holes are core drilled in existing structures, sleeves shall be provided as specified complete with fire stopping as noted above.
- 1.12.15. Submit a complete fire stopping system shop drawing package, identifying the products that may be used on the project. Prior to submitting data, review with Authority having Jurisdiction to confirm acceptability of proposed materials and assemblies.
- 1.12.16. Installation
- .1 Install fire stopping and smoke seal material and components in accordance with ULC certification and manufacturer's instructions.
  - .2 Seal holes or voids made by through penetrations, poke through termination devices, and un-penetrated openings or joints to ensure continuity and integrity of fire separation are maintained.
  - .3 Provide temporary forming as required and remove forming only after materials have gained sufficient strength and after initial curing.
  - .4 Tool or trowel exposed surfaces to a neat finish.
  - .5 Remove excess compound promptly as work progresses and upon completion.
- 1.13. HOISTING
- 1.13.1. Electrical Contractor will be responsible for the hoisting of all the equipment in the contract. Contractor to coordinate with Prime Contractor for use of the general hoisting facilities. If hoist facilities are inadequate then subcontractors must provide their own. Subcontractors must inform prime contractors of requirements before tender closing date. Any hoisting required in addition to that provided by the General, will be included in the bid price.
- 1.14. CLEANING AND WASTE REMOVAL
- 1.14.1. Clean all electrical equipment that has been exposed to construction dust and dirt.
- 1.14.2. Contractor is responsible to remove their own waste from the site. All re-usable materials shall be recycled.
- 1.15. SPRINKLERS
- 1.15.1. All electrical equipment shall be suitable for installation in a sprinklered environment and enclosures are to be CSA Type-2 sprinkler proof.

---

**1.16. TEMPORARY LIGHT AND POWER**

- 1.16.1. Temporary light and power for construction shall be provided and maintained by the electrical trade, as per site requirements, subject to scope of work; but each trade shall provide all extension cords, lamps, etc., required to complete their work.
- 1.16.2. Provide adequate lighting to meet all health and safety standards.

**1.17. EXAMINATION AND PROTECTION OF SITE**

- 1.17.1. When requested by University's Representative, the Contractor is to provide digital pictures of the site, including but not limited to progress of work and installed equipment, via e-mail to the University's Representative.

**1.18. DRAWINGS AND INSTALLATION**

- 1.18.1. The drawings are intended to show the general character and scope of the work and not the exact details of the installation. The installation shall be complete with all accessories required for a complete and operative installation.
- 1.18.2. The location, arrangement and connection of equipment and materials shown on the drawings represent a close approximation to the intent and requirements of the contract. The right is reserved by the University's Representative to make reasonable changes required to accommodate conditions arising during the progress of the work, at no extra cost to the University.
- 1.18.3. Certain details indicate on the drawings are general in nature and specific labelled detail references to each and every occurrence of use are not indicated, however, such details shall be applicable to every occurrence on the drawings.
- 1.18.4. The actual location of switches, outlets and luminaries, etc. shall be reviewed by the University's Representative before installation.
- 1.18.5. The location and size of existing services shown on the drawings are based on the best available information. The actual location of existing services shall be verified in the field before work is commenced. Particular attention shall be paid to buried services.
- 1.18.6. Leave areas clear where space is indicated as reserved for future equipment, and equipment for other trades.
- 1.18.7. Adequate space and provisions shall be left for removal of components and servicing of equipment, with minimum inconvenience to the operation of systems.
- 1.18.8. Where equipment is shown to be 'roughed-in only' obtain accurate information from the University's Representative before proceeding with the work.
- 1.18.9. Contractor is to review University's specifications, drawings and details to confirm locations of devices and equipment.
- 1.18.10. This Contractor is responsible to mark-out his work, fully co-ordinated with all other trades, in sufficient time for review by the University prior to rough-in. Prepare dimensioned layouts of each room prior to rough-in for review by the University. Do not proceed with any work until the University has reviewed the layout drawings.

**1.19. INSTALLATION, INTERFERENCE AND SETTING DRAWINGS**

- 1.19.1. The Contractor is to complete installation, interference and setting drawings, dimensioned and to scale for all systems. They shall be made available for review by the University's Representative, if requested. The drawings are required to make clear the work intended or

- to show its relation to adjacent work or to the work of other trades. When an alternative piece of equipment is to be substituted for equipment shown, drawings of the area involved shall be prepared by this division.
- 1.19.2. Slab layout drawings are to be submitted for review by the University's Representative. These slab layout drawings are to be included in the as-built drawings. Refer to Section 26 05 03.00 – RECORD DRAWINGS.
- 1.19.3. Interference drawings are required for shafts, ceiling spaces, basement areas, typical floors and wherever there is possible conflict in the positioning of electrical equipment, piping, ductwork sub-trades or architectural features.
- 1.19.4. This Division shall prepare sleeving drawings indicating the size and locations of openings required in concrete floor slabs, roof slabs/decks and walls for conduit, bus ducts and equipment for review by the University. In case of failure to provide information in time (i.e. before the concrete is poured) any extras incurred shall be at the expense of this Division.
- 1.20. APPROVED MANUFACTURERS
- 1.20.1. Where two or more names are shown in the specifications as alternates or equal to, this division can select which manufacturer is to be carried.
- 1.20.2. The Contractor is to list substitute equipment. Acceptance of substitute equipment shall be at the discretion of the University's Representative.
- .1 The proposed substitution shall show product name and complete description.
- .2 Materials and products specified by the name of the manufacturer, the brand or trade name, or catalogue reference, shall be the basis of the Bid Price.
- .3 Any alternate and/or substitute equipment listed shall be equal in performance and quality to that specified. If space, power, structural or any other requirements are different from the equipment specified, the cost of any changes shall be included for in the price shown on the Electrical Supplementary Bid Form.
- .4 The University reserves the right to accept or reject any substitution without question.
- .5 The "Base and Alternate Equipment" is for North American manufactured products. Where a listed manufacturer can offer either North American or non- North American source for the equipment, the country of origin shall be shown under "Substitute Equipment" and the cost savings shown under "Deduct From Tender Price".
- 1.21. PRODUCTS AND MATERIALS
- 1.21.1. Make and quality of materials used in the construction of this project shall be subject to the approval of the University's Representative.
- 1.21.2. All equipment and material are to be CSA certified or approved by an accredited organization. Where there is no alternative to supplying equipment which is not CSA certified, obtain special approval from Electrical Inspection Authorities.
- 1.21.3. Factory assemble control panels and component assemblies.
- 1.21.4. Materials and equipment supplied by this division shall be new and free from defects and shall be equivalent in physical characteristics and performance to that specified by the manufacturer's name and catalogue reference.
- 1.21.5. Where a certain manufacturer's equipment has been specified by name or model number, the contractor shall be responsible for ensuring that the performance and quality meets the specified equipment and that the same access or maintenance space is available for an alternative manufacturer's equipment that is used and that interfacing connections with other

---

trades can be made at no extra cost.

1.21.6. Availability

- .1 In submitting Bid, Contractor warrants that all materials are available in suitable time to meet Contract dates.
- .2 Subject to sentence .3 below, where the Contractor advises that the Contractor cannot supply materials in suitable time to meet Contract dates, and should it subsequently appear that Work may be delayed for such reason, the University's Representative reserves the right to substitute more readily available products of similar character.
- .3 Where the Contractor can show that the Contractor promptly ordered the originally specified materials the University will pay the differential in cost between the originally specified material and the substitute material applicable by the Contractor, subcontractors, subsubcontractors or suppliers. For greater certainty, the Contractor's failure to submit shop drawings or other submittals or seek direction in those instances where the Contract Documents so require in sufficient time to permit ordering materials is not cause for the University to pay the cost differential in sentence .2 above.

1.22. CO-OPERATION WITH OTHER DIVISIONS

- 1.22.1. Particular attention must be paid to the proximity of electrical conduit and cable to mechanical piping and equipment.
- 1.22.2. Electrical conduits shall not touch or be supported on pipe or duct walls.
- 1.22.3. Each section shall confine itself to installing all materials in the spaces shown without encroaching upon space for materials installed under other sections or divisions. Where the space allocated to another section or division is encroached upon, the materials shall be relocated to their proper space allocation in such a manner to complete the work using space allocated to the various sections and divisions. Relocation of materials and work involved shall be paid for by the section responsible for the encroachment at no extra cost to the University.
- 1.22.4. The supply of all items is to have built-in to the delivery schedule, ample time for rapid progress of work. Proceed with work determined by the construction schedule.

1.23. TEMPORARY USE OF EQUIPMENT

- 1.23.1. Where the electrical systems are operated during construction, the Electrical Contractor shall maintain the system and equipment in proper operating condition.
- 1.23.2. Before any area of the building is turned over to the University for acceptance and for beginning of the guarantee/warranty period, the systems and equipment shall be returned to the initial new condition.
- 1.23.3. Permanent electrical equipment is only to be used upon permission of the University's Representative and is only to be used on a limited basis. All equipment must be cleaned prior to turnover.

1.24. METRIC CONVERSIONS

- 1.24.1. Particular care shall be taken with imperial versus S.I. metric conversions. This applies to all services including, but not limited to, equipment, conduit and site services in both new and existing installations.

- 
- 1.25. INTERRUPTION OF SERVICES.
- 1.25.1. Make all necessary arrangements with those concerned.
- 1.25.2. Testing and operation of major equipment shall be approved by the University's Representative to avoid excessive hydro electric charges. Such testing to be generally carried out after normal working hours or on weekends.
- 1.25.3. Contractor to provide a minimum of 5 days written notice of a requirement for a shutdown. Contractor to include for separate meetings with the University's Representative to discuss the shutdown in detail and to coordinate all the work being performed.
- 1.25.4. The Contractor is responsible for any damages caused to existing systems when making connections.
- 1.25.5. The Contractor is to keep shutdowns of existing buildings to a minimum by scheduling the work and providing the required number of personnel to keep the shutdown to a minimum. This Contractor is to include for as many multiple teams of electricians is feasible to keep the shutdown work to the minimum.
2. Products
- 2.1. NOT USED
3. Execution
- 3.1. NOT USED
- END OF SECTION 26 05 01.00

4. General

4.1. WORK INCLUDED

4.1.1. Refer to Section 26 05 01.00 – GENERAL INSTRUCTIONS FOR ELECTRICAL SECTIONS.

5. Products

5.1. RECORD DRAWINGS

5.1.1. After the final as-built drawings have been reviewed, provide copies of the drawings on CD. A minimum of one copy with each set of maintenance manuals. Provide additional copies if required under the General Conditions. The Contractor is to use latest release of AutoCAD software.

5.1.2. The contractor to identify the cost of Record Drawings and the Operation and Maintenance Manuals as a separate line item on their progress draw.

5.1.3. The project will remain incomplete and no money will be released until the final versions, both hard and electronic, of the drawings and manuals are approved.

5.1.4. Final as-built prints/plots shall not contain markings or corrections by hand (i.e. marker, pen, pencil, etc.). References to the Architect/Interior Designer and Engineer must be deleted from the drawings.

5.1.5. Final as-built drawings to include all revisions made to the drawings during construction, including all approved change. The as-built drawings are to also include the routing of all feeders except for branch circuits, all junction boxes to be shown, drawing legend to be updated to include all symbols and lines used for as-builts, quantity of wires in each conduit, and circuit numbers of wires in each conduit. Include slab layout drawings in as-built drawing package.

5.1.6. CAD files are for the Contractor to update to produce as-built drawings for Engineer's Representative review.

6. Execution

6.1. NOT USED

END OF SECTION 26 05 03.00

7. General

7.1. WORK INCLUDED

7.1.1. Conform to Section 26 05 01.00 – GENERAL INSTRUCTIONS FOR ELECTRICAL SECTIONS.

8. Products

8.1. SHOP DRAWINGS

8.2. "SECTION 01340" SHALL APPLY EXCEPT AS AMENDED BELOW.

8.2.1. Submittals/Shop Drawings shall indicate clearly the materials and/or equipment actually being supplied, all details of construction, accurate dimensions, capacity, operating characteristics and performance. Each Shop Drawing shall give the identifying number of the specific assembly for which it was prepared (e.g. MCC-1).

8.2.2. Each Shop Drawing for non-catalogue items shall be prepared specifically for this project. Shop Drawings and brochures for catalogue items shall be marked clearly to show the items being supplied.

8.2.3. Each Shop Drawing or catalogue sheet shall be stamped and signed by the Contractor to indicate that he has checked the drawing for conformance with all requirements of the drawings and specifications, that he has co-ordinated this equipment with other equipment to which it is attached and/or connected and that he has verified all dimensions to ensure the proper installation of equipment within the available space and without interference with the work of other trades. Ensure that electrical co-ordination is complete before submitting drawings for review.

8.2.4. Contractor to submit all submittals/shop drawings electronically in PDF format. Submittal to come complete with a transmittal bound to the PDF file with the transmittal identifying the total number of pages in the submittal including the transmittal page. Submittals to be clear. Photocopies of catalogues are not acceptable.

8.2.5. Installation of any equipment shall not start until after final review of Shop Drawings by the Engineer's Representative has been obtained.

8.2.6. One original Shop Drawing will be returned electronically. All copies required for the trades, suppliers or other Engineer's Representatives will be copied or printed by the Contractor.

9. Execution

9.1. NOT USED

END OF SECTION 26 05 04.00

1. General
  - 1.1. WORK INCLUDED
    - 1.1.1. Conform to Section 26 05 01.00 – GENERAL INSTRUCTIONS FOR ELECTRICAL SECTIONS.
    - 1.1.2. Labour, Products, equipment and services necessary for wire and cables (0-1000V) Work in accordance with the Contract Documents.
  - 1.2. REFERENCES
    - 1.2.1. CSA C22.2 No. .0.3 96 and No. 174, Test Methods for Electrical Wires and Cables.
    - 1.2.2. CAN/CSA C22.2 No. 131 M89(R1994), Type TECK 90 Cable.
2. Products
  - 2.1. BUILDING WIRES
    - 2.1.1. Conductors: solid for up to 10 AWG, stranded for 8 AWG and larger. Minimum size: 12 AWG.
    - 2.1.2. Copper conductors: 98% conductivity size as indicated, with insulation of chemically cross linked thermosetting polyethylene material rated RW90 (90°C) or THHN, minimum 600 volt insulation.
    - 2.1.3. Unless noted otherwise, 300V rating for Fire Alarm, security, and other low voltage circuits, 600V rating for 120/208V and 347/600V circuits.
    - 2.1.4. Colour Coding:
      - .1 120/208V, circuits:
        - Two conductor, 1 phase: 1 black, 1 white
        - Three conductor, 1 phase: 1 red, 1 black, 1 white
        - Three conduct, 3 phase: 1 red, 1 black, 1 blue
        - Four conductor, 3 phase: 1 red, 1 black, 1 blue, 1 white
      - .2 347/600V, circuits:
        - Two conductor, 1 phase: 1 orange, 1 white
        - Three conductor, 1 phase: 1 orange, 1 brown, 1 white
        - Three conductor, 3 phase: 1 orange, 1 brown, 1 yellow
        - Four conductor, 3 phase: 1 orange, 1 brown, 1 yellow, 1 white

The 347/600 volt colour coding of conductors as noted above shall be approved by the local Authorities Having Jurisdiction prior to purchasing and installing.
    - .3 Ground wires: green
  - 2.2. ARMoured CABLES
    - 2.2.1. Conductors: insulated, copper, size as indicated, with 600V R90 insulation.
    - 2.2.2. Type: AC90. Multi-conductor, with solid, annealed commercial grade 98 percent conductivity tinned copper conductors and cross-linked polyethylene with R90 insulation, 600 volt rating, on #10 and #12 size only.

- 
- 2.2.3. Armour: interlocking type fabricated from galvanized steel strip.
  
  - 2.3. VFD CABLES
    - 2.3.1. Cables from Variable Frequency Drives or Variable Speed Drives to motor(s) shall be copper with flame retardant XLPE 90°C wet, 105°C dry RW90 as per CSA 22.2, No 38 thermoset insulated conductors.
    - 2.3.2. Grounding shall consist of 3 seven strand, bare copper symmetrically located in continuous contact with the copper tape shield.
    - 2.3.3. The shielding shall be a copper tape, helically wound with 50% overlap.
    - 2.3.4. The assembly shall consist of 3 phase conductors with symmetrically located trisection grounding conductors in continuous contact with copper tape shield.
    - 2.3.5. Equal to United Wire and Cable "VFD" type.
  - 2.4. MINERAL INSULATED CABLES
    - 2.4.1. Conductors: solid bare soft-annealed copper, size as indicated.
    - 2.4.2. Insulation: compressed powdered magnesium oxide to form compact homogeneous mass throughout entire length of cable and enclosed in a seamless copper sheath with a protective jacket where required.
    - 2.4.3. Overall covering: annealed seamless copper sheath type LWM1 rated 600V, 250EC.
    - 2.4.4. Outer jacket: PVC applied over sheath.
    - 2.4.5. Two hour fire rating.
    - 2.4.6. Connectors and termination kits: moisture proof as per manufacturer's recommendation.
  - 2.5. CONTROL CABLES
    - 2.5.1. Type LVT: 2 soft annealed copper conductors, sized as indicated, with thermoplastic insulation, outer covering of thermoplastic jacket, and armour of closely wound aluminum wire.
  - 2.6. OUTDOOR WIRING
    - 2.6.1. All outdoor wiring shall have copper conductors with RWU-90, X-Link, minus 40°C, 600 volt insulation.
  - 3. Execution
    - 3.1. INSTALLATION
      - 3.1.1. Wire shall be installed in conduit, and sized for the connected load(s) and protection as required, unless otherwise specified.
      - 3.1.2. Minimum wire size shall be #12 AWG, unless otherwise stated. Home runs in excess of 25 m (75 ft.) for circuits protected by a 15A overcurrent device, shall be #10 AWG.
      - 3.1.3. The current carrying capacity of the feeders, subfeeders and branch circuit conductors shall be sized to equal or better than shown on the drawings. If wire or cable sizes with equivalent current carrying capacity other than that specified is used, ensure that the voltage drop shall not be more than 2% to farthest outlet based on circuit rating. Home runs to lighting and receptacle panels which exceed 75 ft. (25M) shall be minimum No. 10 AWG.

- 
- 3.1.4. The number of wires indicated for various systems is intended to show the general scheme only. The required number and type of wires shall be installed in accordance with the manufacturer's diagrams.
- 3.1.5. Zone Conduit Wiring:
- .1 When taking 6 (six) circuits to on-floor zone termination points, provide minimum #10 current carrying wires or as required by voltage drop and #10 neutrals.
- 3.1.6. Wire in Conduit:
- .1 Provide pigtails at all outlets for fixtures and wiring devices. All neutrals and branch circuits shall be connected in each outlet box to avoid a break in the neutral or the circuit wire when fixture or wiring device is disconnected.
- .2 At each junction, pull and outlet box make a 360 deg. loop of the stripped uncut ground conductor under the ground screws.
- 3.1.7. Low Voltage Armoured Cables (Feeders):
- .1 Do not directly bury in or below concrete slabs or walls.
- .2 Do not encircle single conductor cable with ferrous metal.
- .3 No splices will be permitted.
- .4 Single conductors of a three or four wire circuit shall be run with uniform spacing of not less than one cable diameter throughout the feeder length.
- .5 Use wood throated cable clamps to ensure proper and uniform cable spacing.
- .6 Where cables are installed on walls, provide mechanical protection over them up to 2.4m (8 ft.) above finished floor, using a 12 gauge U section aluminum cover.
- .7 Cable connections to all enclosures, boxes and panels shall be by means of a watertight malleable aluminum connector.
- 3.1.8. Low Voltage Armoured Cables - (Branch Circuits):
- .1 These cables must be run concealed and may be used only for the following purposes:
- (a) Final connection from a conduit ceiling box to outlets and receptacles in drywall partitions only.
- (b) Final connections to luminaires for maximum length of 3 m (10 ft.).
- (c) Use insulated throat connectors and anti-short sleeves at all dressed ends.
- 3.1.9. Neutral Supported Cables:
- .1 Install neutral supported cables where shown.
- 3.1.10. Mineral Insulated Cables:
- .1 Run cable exposed, securely supported by straps.
- .2 Make cable terminations by using factory-made kits.
- .3 At cable terminations use thermoplastic sleeving over bare conductors.
- .4 Do not splice cable.
- .5 MI cables shall be used for emergency system feeders and branch circuits requiring a 1 (one) hour fire rating, where rating is not achievable by embedding in poured concrete or

enclosing in fire rated spaces.

- .6 MI cables must be rigidly supported at maximum spacing of 1m (3ft.). Do not use aluminum products for support.

END OF SECTION 26 05 21.00

- 
1. General
    - 1.1. WORK INCLUDED
      - 1.1.1. Conform to Section 26 05 01.00 – GENERAL INSTRUCTIONS FOR ELECTRICAL SECTIONS.
    - 1.2. REFERENCES
      - 1.2.1. CSA C22.2 No. 41-M2007 – Grounding and Bonding of Equipment
    - 1.3. DESCRIPTION
      - 1.3.1. Provide system grounding to meet requirements of current Canadian Electrical Code and all applicable Codes.
      - 1.3.2. Supply and install station ground electrodes, consisting of a minimum of four (4) driven ground rods not less than 3m long and 19.00mm in diameter and where practicable located adjacent to the equipment to be grounded; otherwise install the ground rods at the lowest floor level of the building. Interconnect all ground bars underground with a #4/0 AWG bare ground conductor.
      - 1.3.3. Supply and install a new ground bus system, consisting of a length of copper bus, 25 mm (1 in.) thick ebony pad with chamfered edges as shown on the drawings. Where a perimeter ground bus is shown on the drawings, supply and install a 50mm x 6mm on all walls attached at 1.5m intervals on 13mm standoffs. The perimeter ground bus shall be continuous around the room and shall be continued above or below all such opening as door and vents. Supply and install inspection box for each ground rod. Inspection box is to be suitable for installation in heavy traffic areas and is to come complete with a lockable lid and security key.
      - 1.3.4. Connect each ground bar with a minimum of two #4/0 AWG conductors to the main ground grid for the building. Connect the ground bar to each of the ground rods with #3/0 minimum ground conductors if the ground rods are driven in the respective room otherwise run a minimum of two #4/0 AWG conductors to the remote ground grid.
      - 1.3.5. Connect to the ground loop all transformer neutrals, switchboard neutral and all metal equipment enclosures as well as all other metal parts such as mechanical pipes, ducts, waste lines, door frames, railings, grilles, fences, etc.
      - 1.3.6. Provide cable grips to receive all grounding conductors. Identify all grounding conductors at the ground pad using lamacoid nameplates. Ground bus system to be provided in rooms as shown.
      - 1.3.7. Terminate the following conductors at the ground bus system:

Service neutral	-3/0 AWG
Telephone ground	-2 AWG
Main system ground	-3/0 AWG
Bonding cable	-3/0 AWG
      - 1.3.8. All metal parts at the electrical area main distribution center shall be bonded to the main ground bus using 4 AWG stranded bare copper cable or 6 mm x 13 mm (1/4 in. x 1/2 in.) copper strap.

- 
- 1.3.9. Bond and ground all metallic water and waste systems in accordance with code requirements.
  - 1.3.10. Install grounding connections to typical equipment included in, but not necessarily limited to, following list: frames of motors, starters, control panels, building steel work, elevators, distribution panels and outdoor lighting.
  - 1.3.11. Commission an approved Agency to perform a main system ground test and a copy of the report in the maintenance manual. (Refer to Part 3.0).

## 2. Products

### 2.1. GROUNDING & BONDING EQUIPMENT

- 2.1.1. Meet standard of CSA C22.2 No. 41-M2007.

### 2.2. CONDUCTORS

- 2.2.1. Bare or insulated, stranded, soft drawn annealed copper wire, for: ground bus, electrode interconnections, metal structures, ground connections, telephone ground.

## 3. Execution

### 3.1. INSTALLATION

- 3.1.1. Install complete permanent, continuous, system and circuit, equipment, grounding systems including, conductors, connectors, accessories, as indicated, to conform to requirements of local authority having jurisdiction over installation.
- 3.1.2. Install connectors in accordance with manufacturer's instructions.
- 3.1.3. Install minimum four (4) ground rods spaced at least the rod length apart and located at the lowest floor of the building.
- 3.1.4. Ground rods to be interconnected by ground grid conductors (size as per table above) and buried to a maximum depth of 600mm below the rough station grade and a minimum depth of 150mm below the finished station grade.
- 3.1.5. Protect exposed grounding conductors from mechanical injury.
- 3.1.6. All grounding connections to be made with two hole, long barrel compression type fittings and lugs.
- 3.1.7. Install bonding wire for flexible conduit, connected at both ends to grounding bushing, solderless lug, clamp or cup washer and screw. Neatly cleat bonding wire to exterior of flexible conduit.
- 3.1.8. The contractor shall pay for the testing and verification of the entire building ground system using a certified testing agency. Tests shall include main ground grid and ground rods, ground connections between all service and communication rooms. The agency shall provide complete test reports indicating test methodology and results. All costs shall be included in contract bid.

END OF SECTION 26 05 26.00

1. General
  - 1.1. WORK INCLUDED
    - 1.1.1. Conform to Section 26 05 01.00 – GENERAL INSTRUCTIONS FOR ELECTRICAL SECTIONS.
  - 1.2. PRODUCT DATA
    - 1.2.1. Conduit and equipment provided under the Electrical contractor shall be complete with all necessary supports and hangers required for a safe and workmanlike installation.
2. Products
  - 2.1. MATERIALS
    - 2.1.1. Provide “U” type support Strut as manufactures by Unistrut.
3. Execution
  - 3.1. INSTALLATION
    - 3.1.1. The Contractor to supply anchor bolts and base diagrams of equipment showing exact location for anchor bolts.
    - 3.1.2. It shall be the responsibility of the electrical contractor to supply the Contractor with anchor bolts and base diagrams of equipment showing exact location of anchor bolts.
    - 3.1.3. All drilling for hangers, rod inserts and work of similar nature shall be done by this Division.
    - 3.1.4. Auxiliary structural members shall be provided under the electrical section concerned where conduits or equipment must be suspended between the joists or beams of the structure, or where required to replace individual hanger to allow for installation on new services. Submit details for review as requested.
    - 3.1.5. Depending on type of structure, hangers shall be either clamped to steel beams or joists, or attached to approved concrete inserts.
    - 3.1.6. Approved type expansion shields and bolts may be used for conduit up to 100 mm (4 in.) diameter where the presetting of concrete inserts is not practical. Submit Shop Drawings.
    - 3.1.7. Suspension from metal deck shall not be allowed unless specifically accepted by the University’s Representative. Drawings of the proposed method of suspension must be submitted for review.
    - 3.1.8. Hangers, hanger rods and inserts in all parking and ramp areas shall meet the requirements of CAN/CSA-S413-07 and shall be of corrosion-resistant material or have an effective, durable corrosion resistant coating. Submit samples for approval.
    - 3.1.9. Suspending one hanger from another shall not be permitted.
    - 3.1.10. All hangers, supports, brackets and other devices used outside the building wall shall be galvanized. If galvanized components cannot be used submit samples of proposed substituted for review before installation.

END OF SECTION 26 05 29.00

- 
1. General
    - 1.1. WORK INCLUDED
      - 1.1.1. Section 26 05 01.00 – GENERAL INSTRUCTIONS FOR ELECTRICAL SECTIONS.
      - 1.1.2. Section 21 05 63.00 – ACCESS DOORS AND ACCESSIBILITY
    - 1.2. REFERENCE
      - 1.2.1. CSA 2.2.1 - Canadian Electrical Code - Part 1.
    - 1.3. SHOP DRAWINGS AND PRODUCT DATA
      - 1.3.1. Submit shop drawings and product data in accordance with Section 21 05 03.00 – Shop Drawings.
  2. Products
    - 2.1. SPLITTERS
      - 2.1.1. Sheet metal enclosure, welded corners and formed hinged cover suitable for locking in closed position. Provide CSA Type 1 enclosures in non-sprinklered environments and CSA Type 4/12 in sprinklered environments.
      - 2.1.2. Main and branch lugs to match required size and number of incoming and outgoing conductors as indicated.
      - 2.1.3. At least three spare terminals on each set of lugs in splitters less than 400 A.
    - 2.2. JUNCTION AND PULL BOXES
      - 2.2.1. Welded steel construction with screw-on flat covers for surface mounting.
      - 2.2.2. Covers with 25 mm (1 in.) minimum extension all around, for flush-mounted pull and junction boxes.
    - 2.3. CABINETS
      - 2.3.1. Type E: sheet steel, hinged door and return flange overlapping sides, handle, lock and catch, for surface mounting.
      - 2.3.2. Type T: sheet steel cabinet, with hinged door, latch, lock, 2 keys, containing 19 mm (3/4 in.) plywood backboard for surface or flush mounting. The plywood backboard is to have a fire- resistant coating on the front.
  3. Execution
    - 3.1. SPLITTER INSTALLATION
      - 3.1.1. Install splitters and mount plumb, true and square to the building lines.
      - 3.1.2. Extend splitters full length of equipment arrangement except where indicated otherwise.

3.2. JUNCTION, PULL BOXES AND CABINETS INSTALLATION

- 3.2.1. Install pull boxes in inconspicuous but accessible locations.
- 3.2.2. Mount cabinets with top not higher than 2 m (8 ft.) above finished floor.
- 3.2.3. Install terminal block as indicated in Type T cabinets.
- 3.2.4. Only main junction and pull boxes are indicated. Install pull boxes as follows:
  - .1 A conduit run exceeds 30 m (98 ft. 5 in.) and;
  - .2 360 degree of combined bends between pull boxes for power conduits or 180 degree of combined bends between pull boxes for communication and low voltage conduits.

3.3. IDENTIFICATION

- 3.3.1. Provide equipment identification. Install identification labels indicating system name voltage and phase.

END OF SECTION 26 05 31.00

- 
1. General
    - 1.1. WORK INCLUDED
      - 1.1.1. Conform to Section 26 05 01.00 – GENERAL INSTRUCTIONS FOR ELECTRICAL SECTIONS.
    - 1.2. REFERENCES
      - 1.2.1. CSA C22.1-Canadian Electrical Code, Part 1.
  2. Products
    - 2.1. OUTLET AND CONDUIT BOXES GENERAL
      - 2.1.1. Size boxes in accordance with CSA C22.1.
      - 2.1.2. Square or larger outlet boxes as required for special devices.
      - 2.1.3. Gang boxes where wiring devices are grouped.
      - 2.1.4. Blank cover plates for boxes without wiring devices.
      - 2.1.5. 347V outlet boxes for 347 V switching devices.
      - 2.1.6. Combination boxes with barriers where outlets for more than one system are grouped.
    - 2.2. SHEET STEEL OUTLET BOXES
      - 2.2.1. Electro-galvanized steel single and multi-gang flush device boxes for flush installation, minimum size 75 mm x 50 mm x 38 mm (3 in. x 2 in. x 1-1/2 in.) or as indicated. 100 mm (4 in.) square outlet boxes when more than one conduit enters one side with extension and plaster rings as required.
      - 2.2.2. Provide cast FS aluminum boxes with factory-threaded hubs and mounting feet for surface wiring of switches and receptacles connected to rigid conduit.
      - 2.2.3. Provide electro-galvanized steel utility boxes for surface mounted boxes connected to surface-mounted EMT conduit, minimum size 100 mm x 54 mm x 48 mm (4 in. x 2-1/8 in. x 1-7/8 in.).
      - 2.2.4. Square or octagonal outlet boxes for lighting fixture outlets.
      - 2.2.5. Square outlet boxes with extension and plaster rings for flush mounting devices in finished plaster or tile walls.
    - 2.3. MASONRY BOXES
      - 2.3.1. Electro-galvanized steel masonry single and multi-gang boxes for devices flush mounted in exposed block walls.
    - 2.4. CONCRETE BOXES
      - 2.4.1. Electro-galvanized sheet steel concrete type boxes for flush mount in concrete with matching extension and plaster rings as required.

## 2.5. FLOOR BOXES

- 2.5.1. Concrete tight electro-galvanized sheet steel floor boxes with adjustable finishing rings to suit floor finish with brushed aluminum faceplate. Device mounting plate to accommodate short or long ear duplex receptacles. Minimum depth: 28 mm (1-1/8 in.) for receptacles; 73 mm (2-7/8 in.) for communication equipment.
- 2.5.2. Adjustable, watertight, concrete tight, cast floor boxes with openings drilled and tapped for 12.7 mm (1/2 in.) and 19 mm (3/4 in.) conduit. Minimum size: 73 mm (2-7/8 in.) deep.

## 2.6. OUTLET BOXES FOR NON-METALLIC SHEATHED CABLE

- 2.6.1. Electro-galvanized, sectional, screw ganging steel boxes, minimum size 75 mm x 50 mm x 63.5 mm (3 in. x 2 in. x 2½ in.) with two double clamps to take non-metallic sheathed cables.

## 2.7. FITTINGS - GENERAL

- 2.7.1. Bushing and connectors with nylon insulated throats.
- 2.7.2. Knock-out fillers to prevent entry of debris.
- 2.7.3. Conduit outlet bodies for conduit up to 31.75 mm (1-1/4 in.) and pull boxes for larger conduits.
- 2.7.4. Double locknuts and insulated bushings on sheet metal boxes.

## 2.8. SERVICE FITTINGS

- 2.8.1. 'High tension' receptacle fitting made of 2 piece die-cast aluminum with brushed aluminum housing finish for duplex receptacles. Bottom plate with two knockouts for centered or offset installation.
- 2.8.2. Pedestal type 'low tension' fitting made of 2 piece die cast aluminum with brushed aluminum housing finish to accommodate amphenol jack connectors.

## 3. Execution

### 3.1. INSTALLATION

- 3.1.1. Support boxes independently of connecting conduits.
- 3.1.2. Fill boxes with paper, sponges or foam or similar approved material to prevent entry of debris during construction. Remove upon completion of work.
- 3.1.3. For flush installations mount outlets flush with finished wall using plaster rings to permit wall finish to come within 6 mm (1/4 in.) of opening.
- 3.1.4. Provide correct size of openings in boxes for conduit, mineral insulated and armoured cable connections. Reducing washers are not allowed.

END OF SECTION 26 05 32.00

- 
1. General
    - 1.1. WORK INCLUDED
      - 1.1.1. Section 26 05 01.00 – GENERAL INSTRUCTIONS FOR ELECTRICAL SECTIONS.
      - 1.1.2. Section 26 05 31.00 – SPLITTERS, JUNCTION, PULL BOXES AND CABINETS
      - 1.1.3. Section 26 05 32.00 – OUTLET BOXES, CONDUIT BOXES AND FITTINGS
    - 1.2. REFERENCES
      - 1.2.1. Canadian Standards Association (CSA)
        - .1 CAN/CSA C22.2 No.18- Outlet Boxes, Conduit Boxes, and Fittings.
        - .2 CSA C22.2 No.45- Rigid Metal Conduit.
        - .3 CSA C22.2 No.56- Flexible Metal Conduit and Liquid-Tight Flexible Metal Conduit.
        - .4 CSA C22.2 No.83- Electrical Metallic Tubing.
        - .5 CSA C22.2 No.211.2- Rigid PVC (Unplasticized) Conduit.
        - .6 CAN/CSA C22.2 No.227.3- Flexible Nonmetallic Tubing.
        - .7 CSA C22.2 No.227.1 - Electrical Non-Metallic Tubing.
  2. Products
    - 2.1. CONDUITS
      - 2.1.1. Rigid metal conduit: to CSA C22.2 No.45, galvanized steel or aluminum threaded.
      - 2.1.2. Epoxy coated conduit: to CSA C22.2 No.45, with zinc coating and corrosion resistant epoxy finish inside and outside.
      - 2.1.3. Electrical metallic tubing (EMT): to CSA C22.2 No.83, with couplings.
      - 2.1.4. Rigid PVC conduit: to CSA C22.2 No.211.2.
      - 2.1.5. Flexible metal conduit: to CSA C22.2 No.56, steel or liquid-tight flexible metal.
      - 2.1.6. Electrical non-metallic tubing (ENT): to CSA C 22.2 No. 227, with couplings.
    - 2.2. CONDUIT FASTENINGS
      - 2.2.1. One hole steel straps to secure surface conduits NPS 2 and smaller. Two hole steel straps for conduits larger than NPS 2.
      - 2.2.2. Beam clamps to secure conduits to exposed steel work.
      - 2.2.3. Channel type supports for two or more conduits at 1 m oc.
      - 2.2.4. Hot dipped galvanized threaded rods, 6 mm (1/4 in.) dia. minimum, to support suspended channels.
    - 2.3. CONDUIT FITTINGS
      - 2.3.1. Fittings: manufactured for use with conduit specified. Coating: same as conduit.
      - 2.3.2. Factory "ells" where 90 bends are required for 1" and larger conduits when a hydraulic bender

- 
- is not used.
- 2.3.3. Connectors, couplings and straps for EMT conduit are to be set-screw steel type. In a sprinklered environment, provide watertight fittings and “O” rings on all vertical conduit runs or when conduit is terminated at any piece of electrical equipment.
- 2.3.4. Provide plastic bushings for all connectors, rigid nipples and rigid conduit 1-1/4” or larger.
- 2.4. EXPANSION FITTINGS FOR RIGID CONDUIT
- 2.4.1. Watertight expansion fittings with integral bonding jumper suitable for linear expansion and 19 mm (3/4 in.) deflection in all directions.
- 2.5. FISH CORD
- 2.5.1. Fish cord to be made of polypropylene.
3. Execution
- 3.1. INSTALLATION
- 3.1.1. All conduits on project to be either surface mounted or in cast in-place concrete or in slab conduits on compliance with the terms of the RFP documents or any amendments to the document as agreed to by the University and/or their reps.
- 3.1.2. Install conduits to conserve headroom in exposed locations and cause minimum interference in spaces through which they pass.
- 3.1.3. Conceal conduits except in mechanical and electrical service rooms or in unfinished areas. Conduits to have their own support system and are to be supported independently of the ceiling grid or ceiling support system.
- 3.1.4. Where vertically runs conduit passes through a slab, Contractor to provide a 100mm (4”) high concrete pad with the pad extending 100mm on all sides of the conduit.
- 3.1.5. Use electrical metallic tubing (EMT) conduit except where specified otherwise.
- 3.1.6. Use epoxy coated conduit in corrosive areas.
- 3.1.7. Use rigid galvanized steel threaded conduit where conduit is subject to mechanical injury.
- 3.1.8. Use rigid PVC conduit underground or in corrosive areas, where indicated.
- 3.1.9. Use flexible metal conduit for connection to motors or vibrating equipment in dry areas, connection to recessed incandescent fixtures without a prewired outlet box, connection to surface or recessed fluorescent fixtures and work in movable metal partitions.
- 3.1.10. Use liquid tight flexible metal conduit for connection to motors or vibrating equipment in damp, wet or corrosive locations. Use only liquid tight fittings when using liquid tight flexible metal conduit. Liquid tight flexible metal conduit to have a jacket with an FT6 rating when used in plenums otherwise provide a minimum FT4 rating.
- 3.1.11. Use explosion proof flexible connection for connection to explosion proof motors.
- 3.1.12. Install conduit sealing fittings in hazardous areas. Fill with compound.
- 3.1.13. Minimum conduit size for lighting and power circuits: NPS 21mm (3/4”).
- 3.1.14. Install EMT conduit from a raised floor branch circuit panel to outlet boxes located in sub floor.
- 3.1.15. Install EMT conduit from a raised floor branch circuit panel to junction box in sub-floor. Run flexible metal conduit from junction box to outlet boxes for equipment connections in sub-floor.

- 
- 3.1.16. Bend conduit cold. Replace conduit if kinked or flattened more than 1/10th of its original diameter.
  - 3.1.17. Mechanically bend steel conduit over 19 mm (3/4 in.) dia.
  - 3.1.18. Field threads on rigid conduit must be of sufficient length to draw conduits up tight.
  - 3.1.19. Install fish cord in empty conduits.
  - 3.1.20. Run 2-NPS 1 spare conduits up to ceiling space and 2-NPS 1 spare conduits down to sub-floor space from each flush panel. Terminate these conduits in 152 x 152 x 102 mm (6 in. x 6 in. x 4 in.) junction boxes or in case of an exposed concrete slab, terminate each conduit in flush concrete or surface type box.
  - 3.1.21. Remove and replace blocked conduit sections. Do not use liquids to clean out conduits.
  - 3.1.22. Dry conduits out before installing wire.
  - 3.1.23. All cutting and patching of masonry/concrete floors, walls, and roof for electrical services shall be by this Division. Obtain approval from the University before cutting any structural walls or floors. Cutting and drilling shall only be at times allowed by the Landlord. Check and verify the location of existing mechanical and electrical services in walls and below the floor slab in all areas requiring core drilling and cutting. Protect all tenant areas where core drilling occurs. Carefully chip top and bottom of slab to expose rebars to minimize cutting of rebars when core drilling. Provide x-ray study before drilling or cutting where required by the University.
  - 3.1.24. Provide sleeves for all new conduit passing through floor and roof slabs, beams, concrete walls and slab to slab partitions, etc.
  - 3.1.25. Where cables and conduits pass through partitions and through floors that are not fire rated, provide an air-tight seal around the cables and conduits.
  - 3.1.26. Where cables and conduits pass through floors and fire rated walls, pack space between conduit (or cable) and sleeve with an approved fire stop as specified in Section 26 05 01.00 – GENERAL INSTRUCTIONS FOR ELECTRICAL SECTIONS.
  - 3.1.27. Prior to installation of any wire or cable in the ducts, pull through each duct a flexible mandrel not less than 300 mm (1 ft.) long and size for the internal diameter of duct, followed by stiff bristle brush to remove sand, earth and other foreign matter. Avoid disturbing or damaging ducts where concrete has not set completely. Notify the University's Representative no less than 48 hours prior to the event, so that the University's Representative may witness.
- 3.2. SURFACE CONDUITS
- 3.2.1. Run parallel or perpendicular to building lines.
  - 3.2.2. Locate conduits behind infrared or gas fired heaters with 1.5 m (5 ft.) clearance.
  - 3.2.3. Run conduits in flanged portion of structural steel.
  - 3.2.4. Group conduits wherever possible on suspended or surface mounted channels.
  - 3.2.5. Do not pass conduits through structural members, except as indicated.
  - 3.2.6. Do not locate conduits less than 75 mm (3 in.) parallel to steam or hot water lines with minimum of 25 mm (1 in.) at crossovers.
  - 3.2.7. Conduits must not be used to support other conduits.
- 3.3. CONCEALED CONDUITS
- 3.3.1. Run parallel or perpendicular to building lines.
  - 3.3.2. Do not install horizontal runs in masonry walls.

- 
- 3.3.3. Do not install conduits in terrazzo or concrete toppings.
  - 3.4. CONDUITS IN CAST-IN-PLACE CONCRETE
    - 3.4.1. Locate to suit reinforcing steel. Install in centre one third of slab.
    - 3.4.2. Protect conduits from damage where they stub out of concrete.
    - 3.4.3. Install sleeves where conduits pass through slab or wall.
    - 3.4.4. Provide oversized sleeve for conduits passing through waterproof membrane, before membrane is installed. Use cold mastic between sleeve and conduit.
    - 3.4.5. Do not place conduits in slabs in which slab thickness is less than 4 times conduit diameter.
    - 3.4.6. Encase conduits completely in concrete with minimum 25 mm (1 in.) concrete cover.
    - 3.4.7. Organize conduits in slab to minimize cross-overs.
  - 3.5. CONDUITS IN CAST-IN-PLACE SLABS ON GRADE
    - 3.5.1. Run conduits 25 mm (1") and larger below slab and encased in 75 mm (3 in.) concrete envelope. Provide 50 mm (2 in.) of sand over concrete envelope below floor slab.
  - 3.6. CONDUITS UNDERGROUND
    - 3.6.1. Slope conduits to provide drainage.
    - 3.6.2. For all non-PVC conduits run underground, provide waterproof joints with heavy coat of bituminous paint.

END OF SECTION 26 05 34.00

- 
1. General
    - 1.1. WORK INCLUDED
      - 1.1.1. Conform to Section 26 05 01.00 – GENERAL INSTRUCTIONS FOR ELECTRICAL SECTIONS.
  2. Products
    - 2.1. EQUIPMENT IDENTIFICATION
      - 2.1.1. Identify electrical equipment with nameplates and labels as follows:
        - .1 Nameplates:
          - .1 Lamacoid 3 mm (1/8 in.) thick plastic engraved sheet, black or red face, white core, mechanically attached with self tapping screws.
          - .2 White letters 20 mm (3/4 in.) high for major switchboards, panelboards and power transformers.
          - .3 White letters 12 mm (1/2 in.) high for terminal boxes, junction boxes, grid boxes, splitter boxes, disconnect switches starters and contactors.
          - .4 Allow for an average of twenty-five (25) letters per nameplate.
          - .5 Identification to be in English.
          - .6 Black nameplates for normal power.
          - .7 Red nameplates for emergency power.

Sample:

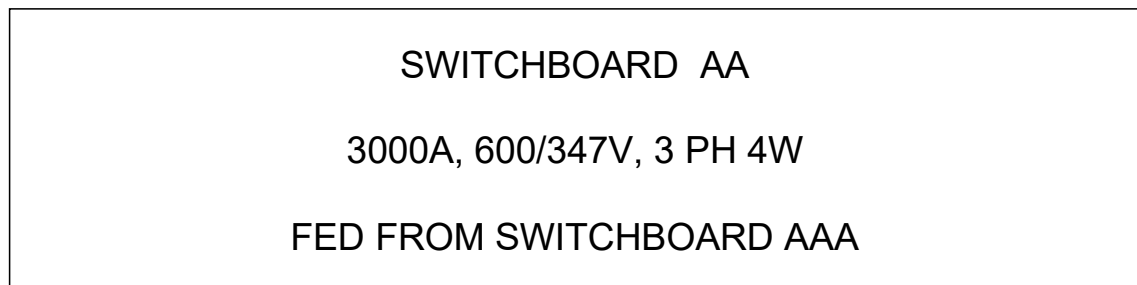

- .2 Labels:
  - .1 Embossed plastic labels with 6 mm (1/4 in.) high letters unless specified otherwise, for internal components, such as relays, fuses, terminal blocks.
  - .2 Wording on nameplates to be approved by University's Representative prior to manufacture.
  - .3 Identification to be in English.
  - .4 Nameplates for terminal cabinets, grid boxes pull boxes, and junction boxes are to indicate the system and/or voltage characteristics.
  - .5 Disconnects, starters and contactors: indicate equipment being controlled and voltage.
  - .6 Transformers: indicate capacity, primary and secondary voltages.

2.1.2. Equipment identification to be permanently fastened to the respective equipment with rivets.

2.2. WIRING IDENTIFICATION

2.2.1. Identify wiring with permanent legible identifying markings, either numbered or coloured plastic tapes, on both ends of phase conductors of feeders and branch circuit wiring.

2.2.2. Maintain phase sequence and colour coding throughout.

2.2.3. Colour code: to CSA C22.1-1998.

2.2.4. Use colour coded wires in communication cables and control wiring, matched throughout system.

2.3. CONDUIT AND CABLE IDENTIFICATION

2.3.1. Colour code conduits, boxes and metallic sheathed cables.

2.3.2. Code with plastic tape or paint at points where conduit or cable enters wall, ceiling, or floor, and at 15 m (50 foot) intervals.

2.3.3. Colours: 25 mm (1 in.) wide prime colour and 20 mm (3/4 in.) wide auxiliary colour.

	<b>Colour</b>
up to 250 V Normal Power	Green
up to 600 V Normal Power	Blue
up to 250 V Emergency Power	Black
up to 600 V Emergency Power	Orange
Medium Voltage	Large independent label clearly identifying the voltage
Telephone/Data	White
Fire alarm	Red
Other security systems	Yellow
Controls	Purple

2.4. RECEPTACLE IDENTIFICATION

2.4.1. All receptacles are to be labelled with the respective circuit numbers with a printed label, similar to a Brady label, with 12mm characters. Circuit number to include full circuit number including panel board identification.

2.4.2. Label to be placed on wall above cover plate or on cover plate. Location of label to be consistent throughout project.

2.5. WIRING TERMINATION

2.5.1. Lugs, terminals, screws used for termination of wiring to be suitable for either copper or aluminum conductors.

2.5.2. Lugs, terminals, screws used for termination of multiple wires must be rated for their intended use.

2.6. MANUFACTURERS AND CSA LABELS

2.6.1. Visible and legible after equipment is installed.

2.7. WARNING SIGNS

2.7.1. Provide warning signs, as specified, and/or to meet the requirements of the Inspection Authorities.

2.8. FUSE SIZE LABELLING

2.8.1. Contractor to install a label on all equipment with fuses to identify the fuse sizes that are installed in the respective equipment.

2.8.2. Contractor to also install a label on all equipment with fuses to identify the maximum allowable fuse size based on the size of the respective feeders.

3. Execution

3.1. NOT USED

END OF SECTION 26 05 53.00

1. General
  - 1.1. WORK INCLUDED
    - 1.1.1. Conform to Section 26 05 01.00 – GENERAL INSTRUCTIONS FOR ELECTRICAL SECTIONS.
2. Products
  - 2.1. MATERIALS
    - 2.1.1. Sleeves passing through stud partitions shall be 0.75 mm (1/32 in.) 22 US Gauge steel.
    - 2.1.2. Sleeves passing through masonry walls shall be Schedule 40 steel pipe.
    - 2.1.3. Sleeves passing through floors in finished areas and concealed spaces may be sheet metal or factory fabricated reusable type.
    - 2.1.4. Sleeves passing through floors in electrical rooms, mechanical rooms, garages or other similar rooms in all areas except slab on grade, shall extend 50 mm (2 in.) above the housekeeping pad and shall be Schedule 40 steel pipe.
    - 2.1.5. Where a housekeeping pad cannot be installed, sleeves passing through floors with waterproof membrane shall have a flashing collar, 50 mm (2 in.) wide at the membrane level. Flashing collar shall be continuously welded to sleeve. Sleeves shall extend 50 mm (2 in.) above the finished floor and shall be Schedule 40 steel pipe.
    - 2.1.6. Where conduits pass through exterior foundation walls 6 mm (1/4 in.) thick steel sleeve of inside diameter not less than 75 mm (3 in.) greater than the outside diameter of the pipe shall be used and shall be complete with anchor collar. Thunderline Link-Seal wall seal as distributed by Corrosion Service Co. Ltd. shall be used for the annular space between the sleeve and the conduit. A reinforced concrete bridge shall be installed between the wall and the adjacent undisturbed soil.
    - 2.1.7. Provide adequate bracing for support of sleeves during concrete and masonry work.
3. Execution
  - 3.1. INSTALLATION
    - 3.1.1. Arrange for all chases and formed openings in walls and floors as required by the Electrical contractor for the Electrical services. These chases and openings shall not be larger than necessary to accommodate the equipment and services. Advise on these requirements well in advance, before the concrete is poured and the walls are built. All necessary sleeves and inserts shall be supplied by this Division.
    - 3.1.2. Chases and openings not located in accordance with the above provisions shall be made at the expense of this Division. Cutting of structural members shall not be permitted without specified written acceptance of the University's Representative.
    - 3.1.3. Provide sleeves for all service penetrations through walls, partitions, floor slabs, plenums and similar barriers. At non-rated barriers fill the annular space between the service and the sleeve with fire rated insulation as specified for rated separations and

- 
- caulk around the edges with a minimum 12 mm (1/2 in.) thick of fire rated compound or acoustic non-setting mastic.
- 3.1.4. Through all fire or smoke separations, after testing, the annular space between conduit sleeves shall be fire stopped.
- 3.1.5. Where holes are to be installed in existing structure, contractor is to core drill the holes required. Contractor is required to scan all areas prior to coring and confirm layout with University prior to completing work. When installing sleeves in existing structures, sleeves shall be provided as specified complete with a combination puddle/anchor flange bolted to the floor. Seal watertight between the flange and the floor.
- 3.1.6. All sleeves are to extend 100mm (4") above finished floor to accommodate a 100mm (4") concrete pad. Contractor to pour the concrete pad with the pad extending 100mm on all sides of the sleeve.

END OF SECTION 26 05 83.00

1. General
    - 1.1. WORK INCLUDED
      - 1.1.1. Conform to Section 26 05 01.00 – GENERAL INSTRUCTIONS FOR ELECTRICAL SECTIONS.
      - 1.1.2. Conform to Section 21 05 00.00 – GENERAL INSTRUCTIONS FOR MECHANICAL SECTIONS.
      - 1.1.3. Include for all cutting and patching for all Electrical services.
  
  2. Products
    - 2.1. MATERIALS
      - 2.1.1. All services and materials used for the cutting and patching shall meet all requirements specified in Project Manual , and shall be carried out by experienced workers.
  
  3. Execution
    - 3.1. INSTALLATION
      - 3.1.1. Cut all openings no larger than is required for the services. Core drill for individual services.
      - 3.1.2. Obtain approval from the University's representative before cutting or core drilling any openings or holes.
      - 3.1.3. Patch all openings after services have been installed to match the surrounding finishes.
      - 3.1.4. In existing areas all cutting, except for core drilling for individual services or where specifically noted, is part of this division work.
      - 3.1.5. The cost of cutting, patching and finishing is included in this division contract.
- END OF SECTION 26 05 88.00

1. General
  - 1.1. REFERENCES
    - 1.1.1. Canadian Standards Association (CSA International)  
CSA C22.2No.29 M1989(R2000), Panelboards and enclosed Panelboards Conform to Section 21 05 00.00 – GENERAL INSTRUCTIONS FOR MECHANICAL SECTIONS.
  - 1.2. MANUFACTURERS
    - 1.2.1. Schneider
    - 1.2.2. Eaton
    - 1.2.3. Siemens
  - 1.3. SHOP DRAWINGS
    - 1.3.1. Submit shop drawings in accordance with electrical specifications.
    - 1.3.2. Drawings to include electrical detail of panel, branch breaker type, quantity, ampacity and enclosure dimension.
  - 1.4. PLANT ASSEMBLY
    - 1.4.1. Install circuit breakers in panelboards before shipment.
    - 1.4.2. In addition to CSA requirements manufacturer's nameplate must show fault current that panel, including breakers, has been built to withstand.
  - 1.5. PANELBOARDS
    - 1.5.1. Panelboards: to CSA C22.2No.29 and product of a single manufacturer.
    - 1.5.2. Unless otherwise specified all panelboards shall have copper bus bars withstand capacity per systems coordination and arc flash study. Provide a full size neutral for 600V boards, and a double sized neutral for 120/208V boards, both with same withstand rating as mains.
    - 1.5.3. Sequence phase bussing with odd numbered breakers on left and even on right, with each breaker identified by permanent number identification as to circuit number and phase.
    - 1.5.4. Panelboards shall contain mains, ground and neutral busses, number of circuits, and number and size of branch circuit breakers as indicated.
    - 1.5.5. Provide two keys for each panelboard and key panelboards alike.
    - 1.5.6. Mains: suitable for bolt on breakers.
    - 1.5.7. Trim with concealed front bolts and hinges.
    - 1.5.8. Trim and door finish: baked enamel unless otherwise specified.
    - 1.5.9. For recessed panelboards, paint trim and door to match finish of adjacent surface.
    - 1.5.10. Panelboards shall be factory assembled sprinkler proof type if in sprinkler area, dead front type, enclosed in Code gauge steel equipped with door having concealed hinges, lock

- 
- and panelboard directory, and shall be suitable for surface or flush mounting as required. Panelboards shall be keyed alike and each panelboard shall be provided with two keys.
- 1.5.11. Tandem double density circuit breakers are not acceptable.
- 1.5.12. Panelboards, including tubs, shall be factory finished ANSI 61 grey. Emergency power panelboards shall be red.
- 1.5.13. Panelboards shall be identified as LP (lighting) or RP (receptacle) or E (emergency) followed by the designation letter, voltage and current rating, and the designation of the source of power supplying the panelboard. Example: "LP3A1 120/208V 225A 3PH 4W Fed from Main Switchboard". Panelboard identification shall be on engraved lamacoid plate, white letters 1/2" high on black background for normal power panels, white letters on green background for emergency supply panelboards. Lamacoid plates shall be fastened to the outside of the panelboard with stainless steel screws. Pen size for lettering shall be 1 mm minimum.
- 1.5.14. Panelboard directories shall be typewritten. Directories shall indicate the final room numbers as designated by Office of Space Management (OSM).
- 1.5.15. Provide two 1" empty conduits from each flush mounted panelboard to the ceiling spaces above and below for future installation of wiring. The conduits shall terminate in junction boxes with fish wires.
- 1.5.16. Provide filler plates on all blank breaker space.
- 1.6. BREAKERS
- 1.6.1. Provide breakers to meet design needs.
- 1.6.2. The main breaker shall be separately mounted on top or bottom of panel to suit cable entry. When mounted vertically, down position should open breaker.
- 1.6.3. Provide lock on devices for pipe tracing, fire alarm, emergency, door supervisory, intercom, stairway, exit and night light circuits.
- 1.7. EQUIPMENT IDENTIFICATION
- 1.7.1. Provide equipment identification in accordance with "Identification" section of electrical specifications.
- 1.7.2. Complete circuit directory with typewritten legend showing location and load of each circuit.
2. Execution
- 2.1. INSTALLATION
- 2.1.1. Locate panelboards as indicated and mount securely, plumb, true and square, to adjoining surfaces.
- 2.1.2. Install surface mounted panelboards on plywood backboards. Where practical, group panelboards on common backboard.
- 2.1.3. Connect loads to circuits as indicated.
- 2.1.4. Connect neutral conductors to common neutral bus with respective neutral identified
- END OF SECTION 26 24 16.00

1. General

1.1. SUMMARY

1.1.1. The specifications in this section describe the electrical and mechanical requirements for a protection system provided by high-energy Surge Protective Devices (SPD) formerly called Transient Voltage Surge Suppressors (TVSS). The specified system shall provide effective, high-energy surge current diversion and be suitable for application in ANSI/IEEE C62.41 Category A, B and C environments.

1.1.2. SPDs are designed for repeated limiting of transient voltage surges on 60 Hz Power circuits not exceeding 1000V and designated as follows:

- .1 Type 2 – SPDs hard-wired to distribution equipment after the load side of the service equipment overcurrent device.
- .2 Type 3 – Plug-in SPDs.
- .3 Type 4 – Component SPDs and component assemblies.

1.2. WORK INCLUDED

1.2.1. Conform to Section 26 05 01.00 – GENERAL INSTRUCTIONS FOR ELECTRICAL SECTIONS.

1.3. STANDARDS

1.3.1. The specified system shall be designed, manufactured, tested and installed in compliance with the following codes and standards:

- .1 Institute of Electrical and Electronic Engineers (ANSI/IEEE)
  - .1 C62.11 Standard for Metal-Oxide Surge Arresters for AC Power Circuits (>1 kV), C62.41.1 Guide on the Surge Environment in Low-Voltage (1000V and Less) AC Power Circuits.
  - .2 C62.41.2 Recommended Practice on Characterization of Surges in Low-Voltage (1000V and Less) AC Power Circuits.
  - .3 C62.45 Recommended Practice on Surge Testing for Equipment Connected to Low-Voltage (1000V and Less) AC Power Circuits).
- .2 Federal Information Processing Standards Publication 94 (FIPS PUB 94) – Guideline on Electrical Power for ADP Installations.
- .3 National Fire Protection Association
  - .1 75 Standard for The Protection of Information Technology Equipment.
  - .2 780 Standard for the Installation of Lightning Protection Systems).
- .4 Canadian Electrical Code (latest edition)
- .5 MIL Standard 220B Method of Insertion Loss Measurement
- .6 Underwriters Laboratories UL 1283 and UL 1449 (3rd edition)
- .7 Canadian Standards or (cUL)

1.4. ENVIRONMENTAL REQUIREMENTS

1.4.1. The operating temperature range shall be -25 deg. C. to 60 deg. C. (-15 deg. F. to 140

- 
- deg. F).
- 1.4.2. The unit shall be capable of operation up to 3,960 m (13,000 ft.) above sea level.
- 1.4.3. No appreciable magnetic fields shall be generated.
- 1.5. SUBMITTALS
- 1.5.1. Product Data: Provide catalogue sheets and supporting documentation showing:
- .1 System voltage.
  - .2 UL1449 3rd Edition listing.
  - .3 UL 1449 Voltage Protection Ratings.
  - .4 UL 1449 I-n rating.
  - .5 Dimensions showing construction, lifting and support points, and enclosure details.
  - .6 Per mode and per phase peak surge current ratings.
  - .7 Modes of discrete suppression circuitry.
  - .8 Warranty period and replacement terms.
  - .9 Conductor size, conductor type, and recommended lead length.
- 1.5.2. Manufacturer's Installation Instructions: Indicate application conditions and limitations of use stipulated by product testing agency specified under Regulatory Requirements. Include instructions for storage, handling, protection, examination, preparation, installation, and starting of product. Indicate maximum size of circuit breaker or fuse to be connected for each unit.
- 1.5.3. List and detail all protection systems such as fuses, disconnecting means and protective features.
- 1.5.4. Provide verification that the SPD device complies with the required UL1449 latest edition, latest revision, and CSA or cUL approvals.
- 1.5.5. SPD shall have UL 1283 EMI/RFI filtering with minimum attenuation of -40dB at 100 kHz.
- 1.5.6. For retrofit and side-mounting applications, provide electrical/mechanical drawings showing unit dimensions, weights, installation instruction details, and wiring configuration.
- 1.5.7. Operation and maintenance manuals shall include details for each SPD shipped.
- 1.6. DELIVERY, STORAGE AND HANDLING
- 1.6.1. Equipment shall be handled and stored in accordance with manufacturer's instructions. One (1) copy of manufacturer's instructions shall be included with the equipment at time of shipment.
- 1.7. QUALITY ASSURANCE AND WARRANTY
- 1.7.1. The manufacturer shall provide a full ten (10) year warranty from the date of shipment against any SPD part failure when installed in compliance with manufacturer's written instructions and any applicable national or local code.
2. Product
- 2.1. GENERAL

- 2.1.1. The SPD shall be listed by CSA or cUL to UL's 1283 and UL's 1449 standards (3rd edition, latest revision), and not merely the components or modules. Listing must be verified by a third party approved laboratory.
- 2.1.2. The SPD shall be CSA or cUL/UL 1449 labelled with 200kA Short Circuit Current Rating (SCCR). Fuse ratings shall not be considered in lieu of demonstrated withstand testing of SPD.
- 2.1.3. Every suppression component of every mode, including N-G, shall be protected by internal overcurrent and thermal overtemperature controls. SPDs relying upon external or supplementary installed safety disconnectors do not meet the intent of this specification.
- 2.1.4. Obtain all surge suppression devices from a single manufacturer.
- 2.1.5. The maximum continuous operating voltage (MCOV) of all components for solidly grounded systems shall not be less than 125% for a 120V system and 120% for 220 and 240V systems, and 125% for 347 and 600V systems. All components for resistance grounded systems shall have an MCOV not less than 125% of the line-to-line voltage.
- 2.1.6. All SPD's shall be equipped with a comprehensive monitoring system which shall include a visual panel display providing information on unit status and phase loss/protection loss.
- 2.1.7. Unit Operating Voltage – Refer to drawings for operating voltage and unit configuration.
- 2.1.8. The suppression system shall incorporate thermally protected metal-oxide varistors (MOVs) as the core surge suppression component for the service entrance and all other distribution levels. The system shall not utilize silicon avalanche diodes, selenium cells, air gaps, or other components that may crowbar the system voltage leading to system upset or create any environmental hazards.
- 2.1.9. Protection Modes – The SPD must protect all modes of the electrical system being utilized. The required protection modes are indicated by bullets in the following table:

Configuration	Protection Modes			
	L-N	L-G	L-L	N-G
Wye	•	•	•	•
Delta	N/A	•	•	N/A
Single Split Phase	•	•	•	•
High Leg Delta	•	•	•	•

- 2.1.10. The SPD shall protect all modes L-G, L-N, L-L, and N-G, have discrete suppression circuitry in L-G, L-N and N-G, and have bidirectional, positive and negative impulse protection. Line-to-neutral-to-ground protection is not acceptable where line-to-ground is specified, and accordingly reduced mode units with suppression circuitry built into only 4 modes are not acceptable. In delta systems, line-to-ground-to-line protection is not acceptable where line-to-line is specified.
- 2.1.11. Nominal Discharge Current (In) – All SPDs applied to the distribution system shall have a 20kA In rating regardless of their SPD Type (includes Types 2 and 4) or operating voltage. SPD shall be UL 1449 labelled with this kA I-nominal (I-n) rating.
- 2.1.12. ANSI/UL 1449 3rd Edition Voltage Protection Rating (VPR) – The maximum ANSI/UL 1449 3rd Edition VPR for the device shall not exceed the following:

Modes	208Y/120	480Y/277	600Y/347
-------	----------	----------	----------

L-N; L-G; N-G	700	1200	1500
L-L	1200	2000	2500

2.1.13. Surge Current Capacity – The minimum surge current capacity the device is capable of withstanding shall be as shown in the following table:

Minimum surge current capacity based on ANSI / IEEE C62.41 location category			
Category	Application	Per Phase	Per Mode
C	Service Entrance Locations or distribution equipment rated at 1,000 Amps or more.	300 kA	150 kA
B	Distribution equipment rated less than 1,000 Amps but greater than 400 Amps	200 kA	100 kA
A	Branch Location Panelboards, MCCs, Busway rated at 400 Amps or less	100 kA	50 kA

2.1.14. Internal Fusing - Overcurrent Protection

.1 Every suppression component of every mode, including N-G, shall be protected by internal overcurrent and thermal overtemperature controls. SPDs relying upon external or supplementary installed safety disconnectors do not meet the intent of this specification.

2.1.15. SPD shall be separate from or integral to the electrical equipment. Where an Integral SPD is supplied, unit shall be UL 1449 3<sup>rd</sup> Edition labelled as Type 1 intended for Type 2 applications without need for external or supplemental overcurrent controls.

2.1.16. The suppressor shall include Form C dry contacts (N.O. or N.C.) for remote monitoring capability.

2.2. CATEGORY C LOCATIONS

2.2.1. Provide SPD on the service entrance equipment or distribution equipment rated at 1,000 Amps or more.

2.2.2. The SPD shall have an internal audible alarm with mute on front cover.

2.2.3. SPD's for service entrance locations shall have a transient event counter with LCD panel display and reset button on the front cover.

2.3. CATEGORY B LOCATIONS

2.3.1. SPDs for distribution equipment rated less than 1,000 Amps but greater than 400 Amps shall be as indicated on project drawings.

2.3.2. The SPD shall have an internal audible alarm.

2.4. CATEGORY A LOCATIONS

2.4.1. SPDs for the branch location panelboards, MCCs, busway rated at 400 Amps or less shall be as indicated on project drawings and panel schedules.

2.4.2. The SPD shall have an internal audible alarm.

2.5. DATA & SIGNAL LINE PROTECTION (FOR 24V APPLICATIONS)

- 
- 2.5.1. The unit shall have a data transmission rate up to 10.0 Mbps.
  - 2.5.2. Each conductor shall have less than 2.4 ohm of internal series resistance per wire, and each pair of conductors shall have a peak surge current of no less than 10,000 amps per wire (20,000 amps per pair), 8 x 20 us waveform.
  - 2.5.3. SPD Voltage Protection level shall be less than < 46V.
  - 2.5.4. The response time of the components of the unit shall be less than one nanosecond.

## 2.6. ENCLOSURES

- 2.6.1. All enclosed equipment shall have CSA Type 1 sprinklerproof enclosure, unless otherwise noted.
- 2.6.2. For integral mounted SPD unit, it should be mounted in separate compartment with separate removable cover. For remote mounted SPD unit provide separate enclosure mounted as near to the electrical equipment as possible.

## 2.7. MANUFACTURERS

- 2.7.1. Approved Vendors:
  - .1 Advanced Protection Technologies
  - .2 Eaton Cutler-Hammer
  - .3 Schneider Electric
  - .4 Siemens

## 3. Execution

### 3.1. INSTALLATION

- 3.1.1. Install the SPD with the conductors as short and straight as practically possible. Gently twist conductors together.
- 3.1.2. Installer may reasonably rearrange breaker locations to ensure short & straightest possible leads to SPDs.
- 3.1.3. Follow the SPD manufacturer's recommended installation practice as outlined in the equipment installation manual. The electrical contractor shall ensure that all neutral conductors are bonded to the system ground at the service entrance or the serving isolation transformer prior to installation of the associated SPD.
- 3.1.4. Main service entrance units shall be installed on a breaker, or, where indicated, shall be installed on a non-fused disconnect switch that meets or exceeds the fault current rating of the switchgear. Size of breaker to be confirmed by manufacturer and coordinated with distribution equipment supplier.
- 3.1.5. Distribution, branch panel, and motor control center units shall be installed on dedicated circuit breakers. Size of breaker to be confirmed by manufacturer and coordinated with distribution equipment supplier.
- 3.1.6. The installing contractor shall comply with all applicable codes.

END OF SECTION 26 27 02.00

1. General
  - 1.1. WORK INCLUDED
    - 1.1.1. Section 26 05 01.00 – GENERAL INSTRUCTIONS FOR ELECTRICAL SECTIONS.
    - 1.1.2. Section 26 27 26.00 – WIRING DEVICES.
    - 1.1.3. Section 26 05 21.00 – WIRES AND CABLES 1000V.
  - 1.2. REFERENCE
    - 1.2.1. CSA C22.2 No. 62 – Surface Metal Raceways
  - 1.3. SHOP DRAWINGS AND PRODUCT DATA
    - 1.3.1. Submit shop drawings and product data in accordance with Section 21 05 03.00 – Shop Drawings.
    - 1.3.2. If variations from the reviewed shop drawings occur during the installation of the system, final as built drawings shall be submitted for each floor that has been altered.
2. Products
  - 2.1. SURFACE RACEWAY FOR WIRING DEVICES
    - 2.1.1. The raceway and all system components must be CSA listed.
    - 2.1.2. Raceway to be constructed of galvanized steel unless stainless steel is identified on the drawings. Raceway base shall have a minimum thickness of 1.3 mm (0.050 in.) and the cover shall have a minimum thickness of 1 mm (0.040 in.).
    - 2.1.3. Raceways shall be painted with the colour to be determined by the University at the time of shop drawing stage. Submit available colour selections with the shop drawing submittal.
    - 2.1.4. The raceway shall have a minimum of two compartments unless additional compartments are identified on the drawings. Assembled base and cover shall be a 120 mm (4¾ in.) wide for two section raceway and additional 60 mm (2-3/8 in.) for every additional compartment with a minimum depth of 45 mm (1¾ in.) unless specified otherwise on the drawing.
    - 2.1.5. The raceway shall be a modular design with separate covers for each compartment divided with fixed barriers. The compartment covers to be snap on design, which snap side by side on a common base. Raceway covers shall be enhanced tamper resistant form, where screws are only necessary on access plates and the covers of certain fittings, but not on standard cover lengths. A tool shall be provided to form the shape in the cover flange necessary to maintain enhanced tamper resistance when the cover is field cut. Another tool shall be provided for cutting covers to ensure square field cuts.
    - 2.1.6. Provide all required fittings including, but not limited to flat, internal and external elbows, couplings for joining raceway sections, wire clips, blank end fittings, entrance fittings, and a full complement of device mounting brackets and plates. All fittings shall be an enhanced tamper resistant form and shall be divided with barriers and made to match the size of the accompanying raceway base.
    - 2.1.7. Provide full capacity corner elbows and tee fittings to maintain a controlled 50 mm (2 in.)

- 
- cable bend radius, which meets the specifications for Fiber Optic cabling and exceeds the TIA 569 requirements for communications pathways.
- 2.1.8. Device brackets shall be provided in sizes to match the width of the raceway and with mounting holes appropriately located to ensure proper mounting of devices in all compartments.
- 2.1.9. Device plates shall be made in any length from 152.4 mm (6 in.) to 1.5 m (60 in.) with cut outs to accommodate various combinations of power and/or communication devices in all compartments. Device plates shall be 152.4 mm (6 in.) and 304.8 mm (12 in.) long with a flange to overlap the joint of the adjacent cover. Provide 5% additional device plates for future additions or modifications for all types of devices installed.

## 2.2. MANUFACTURERS

### 2.2.1. The following are approved manufacturers:

- .1 Legrand – Wiremold Anysize.
- .2 Hubbell.

## 3. Execution

### 3.1. INSTALLATION

- 3.1.1. Prior to and during installation, refer to system layout or approval drawings containing all elements of the system. Installer shall comply with detailed manufacturer's instruction sheets, which accompany system components, as well as complete system instruction sheets, whichever is applicable.
- 3.1.2. All raceway systems shall be mechanically continuous and connected to all electrical outlets, boxes, device mounting brackets, and cabinets, also in accordance with manufacturer's installation sheets.
- 3.1.3. All metal raceway shall be electrically continuous and bonded in accordance with the respective Electrical Code for proper grounding. Provide a separate insulated ground conductor in the entire length of the raceway.
- 3.1.4. Raceway shall be securely supported at intervals not exceeding 1500 mm (5 ft.) or in accordance with manufacturer's installation sheets.
- 3.1.5. All raceway systems shall be installed complete, including insulating bushings and inserts where required by manufacturer's installation sheets. All unused raceway openings shall be closed.
- 3.1.6. Locate wireway and wiring devices as shown.
- 3.1.7. Install supports, elbows, tees, connectors and fittings. Keep the number of elbows, offsets and connections to a minimum.
- 3.1.8. Install wiring and wiring devices as indicated.
- 3.1.9. Install barriers to separate different wiring systems.

END OF SECTION 26 27 19.00

- 1. General
  - 1.1. WORK INCLUDED
    - 1.1.1. Conform to Section 26 05 01.00 – GENERAL INSTRUCTIONS FOR ELECTRICAL SECTIONS.
  - 1.2. SHOP DRAWINGS AND PRODUCT DATA
    - 1.2.1. Submit shop drawings and product data in accordance with Section 21 05 03.00 – Shop Drawings.
- 2. Products
  - 2.1. SWITCHES
    - 2.1.1. 20 A, single pole, double pole, three-way, or four-way specification grade switches. Voltage rating of the switch to be as per the contract documents.
    - 2.1.2. Manually-operated general purpose ac switches with following features:
      - .1 Terminal holes approved for No. 10 AWG wire.
      - .2 Silver alloy contacts.
      - .3 Urea or melamine moulding for parts subject to carbon tracking.
      - .4 Suitable for back and side wiring.
      - .5 Décor Style specification grade Rocker switch.
      - .6 Colour to be selected by University's Representative.
    - 2.1.3. Toggle operated locking fully rated for tungsten filament and fluorescent lamps, and up to 80% of rated capacity of motor loads.
  - 2.2. RECEPTACLES
    - 2.2.1. All receptacles to be specification grade.
    - 2.2.2. Duplex specifications receptacles, Décor style CSA type 5-15 R, 125 V, 15 A, U ground, with following features:
      - .1 Thermoplastic with impact-resistant nylon face moulded housing.
      - .2 Suitable for No. 10 AWG for back and side wiring.
      - .3 Eight back wired entrances, four side wiring screws.
      - .4 Triple wipe contacts and riveted grounding contacts.
    - 2.2.3. Single receptacles CSA type 5-15 R, 125 V, 15 A, U ground with following features
      - .1 Thermoplastic moulded housing.
      - .2 Suitable for No. 10 AWG for back and side wiring.
      - .3 Four back wired entrances, 2 side wiring screws.
    - 2.2.4. Other receptacles with ampacity and voltage as indicated.
    - 2.2.5. Receptacles to be coloured as follows:
      - .1 Normal Power – Colour to be selected by University's Representative

- 
- .2 Emergency/Essential Power – Red
  - .3 Isolated Ground – Orange
  - .4 Switched - Green
  - 2.3. MANUFACTURERS
  - 2.3.1. The switches and wiring devices shall be of one manufacturer throughout the project.
  - 2.3.2. The following are acceptable manufacturers:
    - .1 Siemens
  - 2.4. SPECIAL WIRING DEVICES
  - 2.4.1. Pilot lights as indicated, with neon type 0.04 W, 125 V lamp and red plastic lens flush type
  
  - 2.5. COVER PLATES
  - 2.5.1. Cover plates for wiring devices.
  - 2.5.2. Cover plates from one manufacturer throughout project.
  - 2.5.3. Sheet steel utility box cover for wiring devices installed in surface-mounted utility boxes.
  - 2.5.4. Provide stainless steel cover plates, suitable for the respective device, for all devices mounted in flush-mounted outlet boxes located in finished areas.
  - 2.5.5. Sheet metal cover plates for wiring devices mounted in surface-mounted FS or FD type conduit boxes.
  - 2.5.6. Weatherproof double lift spring-loaded cast aluminum cover plates, complete with gaskets for duplex receptacles located outside or as indicated.
  - 2.5.7. Weatherproof spring-loaded cast aluminum cover plates complete with gaskets for single receptacles or switches located outside or as indicated.
  
  - 3. Execution
  
  - 3.1. INSTALLATION
  - 3.1.1. Switches:
    - .1 Install single throw switches with handle in "UP" position when switch closed.
    - .2 Install switches in gang type outlet box when more than one switch is required in one location.
    - .3 Mount toggle switches at height as indicated.
  - 3.1.2. Receptacles:
    - .1 Install receptacles in gang type outlet box when more than one receptacle is required in one location.
    - .2 Mount receptacles at height specified as indicated.
    - .3 Where split receptacle has one portion switched, mount vertically and switch upper portion.
  - 3.1.3. Cover plates:
    - .1 Protect stainless steel cover plate finish with paper or plastic film until painting and other work is finished.
    - .2 Install suitable common cover plates where wiring devices are grouped.

.3 Do not use cover plates meant for flush outlet boxes on surface-mounted boxes.

END OF SECTION 26 27 26.00

1. General
  - 1.1. WORK INCLUDED
    - 1.1.1. Conform to Section 26 05 01.00 – GENERAL INSTRUCTIONS FOR ELECTRICAL SECTIONS.
  - 1.2. REFERENCES
    - 1.2.1. CSA C22.2 No. 248-00 – Low Voltage Fuses.
  - 1.3. SHOP DRAWINGS AND PRODUCT DATA
    - 1.3.1. Submit shop drawings and product data in accordance with specification 21 05 03.00 – Submittals-Shop Drawings.
    - 1.3.2. Submit fuse performance data characteristics for each fuse type and size above 100 A. Performance data to include: average melting time-current characteristics, I<sub>2</sub>t (for fuse coordination), and peak let-through current.
  - 1.4. MAINTENANCE MATERIALS
    - 1.4.1. Three spare fuses of each type and size installed 600 A and above.
    - 1.4.2. Six spare fuses of each type and size installed up to and including 400 A.
  - 1.5. DELIVERY AND STORAGE
    - 1.5.1. Ship fuses in original containers.
    - 1.5.2. Do not ship fuses installed in switchboard.
    - 1.5.3. Store fuses in original containers in moisture free location.
2. Products
  - 2.1. FUSES GENERAL
    - 2.1.1. Fuse type references L1, L2, J1, R1 etc. have been adopted for use in this specification.
    - 2.1.2. Fuses: product of one manufacturer.
    - 2.1.3. Fuses to have an indicating window to identify when the fuse has been blown.
  - 2.2. FUSE TYPES
    - 2.2.1. Class L fuses.
      - .1 Type L1, time delay, capable of carrying 500% of its rated current for 10 s minimum.
      - .2 Type L2, fast acting.
    - 2.2.2. Class J fuses.
      - .1 Type J1, time delay, capable of carrying 500% of its rated current for 10 s minimum.
      - .2 Type J2, fast acting.

- 
- 2.2.3. Class R fuses. For UL Class RK1 fuses, peak let-through current and I<sup>2</sup>t values not to exceed limits of UL 198E-1982, table 10.2.
- .1 Type R1, (UL Class RK1), time delay, capable of carrying 500% of its rated current for 10 s minimum, to meet UL Class RK1 maximum let-through limits.
  - .2 Type R2, time delay, capable of carrying 500% of its rated current for 10 s minimum.
  - .3 Type R3, (UL Class RK1), fast acting Class R, to meet UL Class RK1 maximum let-through limits.
- 2.2.4. Class C fuses.
- 2.2.5. Fuses for Motors:
- .1 All fuses for motor loads are to be time-delay type.
- 2.3. FUSE STORAGE CABINET
- 2.3.1. Fuse storage cabinet, manufactured from 2.0 mm (5/64 in.) thick aluminum 750 mm (2 ft. 6 in.) high, 600 mm (2 ft.) wide, 300 mm (1 ft.) deep, hinged, lockable front access door finished in accordance with Section 26 05 01.00 – GENERAL INSTRUCTIONS FOR ELECTRICAL SECTIONS.
- 2.4. FUSE PULLER
- 2.4.1. Provide a fuse puller for each size of fuse to be located in the fuse storage cabinet. Fuse puller to be clearly labelled for the appropriate building and fuse cabinet. Fuse puller to be equal to the Ideal Safe-T-Grip Fuse Puller
- 2.5. MANUFACTURERS
- 2.5.1. The following are acceptable manufacturers:
- .1 Ferraz Shawmutt
  - .2 Cooper-Bussman
  - .3 Littelfuse
3. Execution
- 3.1. INSTALLATION
- 3.1.1. Install fuses in mounting devices immediately before energizing circuit.
- 3.1.2. Ensure correct fuses fitted to physically matched mounting devices.
- .1 Install Class R rejection clips for Class R fuses.
- 3.1.3. Ensure correct fuses fitted to assigned electrical circuit.
- 3.1.4. Where UL Class RK1 fuses are specified, install warning label "Use only UL Class RK1 fuses for replacement" on equipment.

END OF SECTION 26 28 14.00

1. General
  - 1.1. WORK INCLUDED
    - 1.1.1. Conform to Section 26 05 01.00 – GENERAL INSTRUCTIONS FOR ELECTRICAL SECTIONS.
  - 1.2. REFERENCES
    - 1.2.1. Canadian Standards Association (CSA C22.5 No. 5).
  - 1.3. PRODUCT DATA
    - 1.3.1. Include time-current characteristic curves for breakers with ampacity of 400 A and over or with interrupting capacity of 22,000 A symmetrical (rms) and over at system voltage.
2. Products
  - 2.1. BREAKERS GENERAL
    - 2.1.1. Bolt-on moulded case circuit breaker: quick-make, quick-break type, for manual and automatic operation with temperature compensation for 40 deg. C. (104 deg. F.) ambient.
    - 2.1.2. Common-trip breakers: with single handle for multi-pole applications.
    - 2.1.3. Magnetic instantaneous trip elements in circuit breakers to operate only when value of current reaches setting. Trip settings on breakers with adjustable trips to range from 3-8 times current rating.
    - 2.1.4. Circuit breakers with interchangeable trips as indicated.
  - 2.2. THERMAL MAGNETIC BREAKERS
    - 2.2.1. Moulded case circuit breaker to operate automatically by means of thermal and magnetic tripping devices to provide inverse time current tripping and instantaneous tripping for short circuit protection.
  - 2.3. MAGNETIC BREAKERS
    - 2.3.1. Moulded case circuit breakers to operate automatically by means of magnetic tripping devices to provide instantaneous tripping for short circuit protection.
  - 2.4. FUSED THERMAL MAGNETIC BREAKERS
    - 2.4.1. Fused thermal magnetic breakers with current limiting fuses internally mounted. Time current limiting characteristics of fuses coordinated with time current tripping characteristics of circuit breaker. Coordination to result in interruption by breaker of fault-level currents up to interrupting capacity of breaker. Fuses individually removable and interlocked with breaker. The removal of

---

fuse cover, blowing of a fuse or removal of a fuse, shall trip the breaker.

2.5. SOLID STATE TRIP BREAKERS

2.5.1. Moulded case circuit breaker to operate by means of a solid-state trip unit with associated current monitors and self-powered shunt trip to provide inverse time current trip under overload condition and long time, short time, instantaneous tripping for phase and ground fault short circuit protection.

2.6. ACCESSORIES

2.6.1. Include:

- .1 shunt trip, when electrically operated or when indicated.
- .2 auxiliary switches, when electrically operated or when indicated.
- .3 motor-operated mechanism, when electrical operation indicated.
- .4 on-off locking device.
- .5 handle mechanism.

2.7. MANUFACTURERS

2.7.1. The following are acceptable manufacturers:

- .1 Schneider Electric
- .2 Eaton Cutler-Hammer
- .3 Siemens

3. Execution

3.1. INSTALLATION

3.1.1. Install circuit breakers as indicated.

END OF SECTION 26 28 21.00

1. General
  - 1.1. WORK INCLUDED
    - 1.1.1. Conform to Section 26 05 01.00 – GENERAL INSTRUCTIONS FOR ELECTRICAL SECTIONS.
  - 1.2. REFERENCES
    - 1.2.1. American National Standards Institute (ANSI)
      - .1 ANSI C82.1 97, Electric Lamp Ballasts Line Frequency Fluorescent Lamp Ballast.
      - .2 ANSI C82.4 92, Ballasts for High Intensity Discharge and Low Pressure Sodium Lamps.
    - 1.2.2. American National Standards Institute/Institute of Electrical and Electronics Engineers (ANSI/IEEE)
      - .1 ANSI/IEEE C62.41 1991, Surge Voltages in Low Voltage AC Power Circuits.
    - 1.2.3. American Society for Testing and Materials (ASTM)
      - .1 ASTM F1137 88(1993), Specification for Phosphate/Oil and Phosphate/Organic Corrosion Protective Coatings for Fasteners.
    - 1.2.4. United States of America, Federal Communications Commission (FCC)
      - .1 FCC (CFR47) EM and RF Interference Suppression.
  - 1.3. SHOP DRAWINGS AND SUBMITTALS
    - 1.3.1. Submit shop drawings for lighting fixtures, exit lighting and for lighting controls.
    - 1.3.2. Submit complete photometric data prepared by independent testing laboratory for luminaires where specified, for approval by Consultant.
    - 1.3.3. Photometric data to include: VCP Table and spacing criterion.
    - 1.3.4. Lamps

Submit manufacturer's technical data for lamps which are specified to be installed in fixtures with each luminaire shop drawing attach the lamp technical data. Data shall include:

      - .1 Operating voltage
      - .2 Wattage
      - .3 Rated lumens
      - .4 Rated life
      - .5 Colour temperature
      - .6 Colour rendering index (CRI)
      - .7 Base type
      - .8 Lamp shape

---

### 1.3.5. Ballasts/Drivers

Submit manufacturer's technical data for ballasts which are specified to be installed as indicated in Luminaire Schedule with each luminaire shop drawing. Attach Ballast technical data, which shall include:

- .1 operating watts;
- .2 input voltage;
- .3 power factor;
- .4 temperature range for operation;
- .5 regulation.
- .6 Confirmation of compatibility with Lamp manufacturer.
- .7 Ballasts shall be manufactured to CSA C22.2 No. 74, and meet or exceed the latest requirements of CBM manufacturers.

### 1.3.6. Lenses and Louvres

- .1 All fixtures shall be complete with internal lenses as specified.
- .2 Submit shop drawings of each lens and louvre specified along with fixture shop drawing.

## 2. Products

### 2.1. LAMPS

#### 2.1.1. General

- .1 Provide lamps as indicated in the luminaire schedule. Luminaire schedule to be developed during detailed design stage.
- .2 All lamps of a given fixture designation and lamp type shall be supplied by the same manufacturer, unless otherwise noted.
- .3 Lamp manufacturers shall have been producing lamps for the North American market with a low failure rate.

#### 2.1.2. Colour

- .1 Unless noted otherwise, the following colour performance must be provided
- .2 LED shall have a color temperature of 3500°K. with a CRI of 90.

#### 2.1.3. Life

- .1 LED: minimum of 50,000 hrs to L70, tested in accordance with LM80 / TM21

#### 2.1.4. Shipment

- .1 All lamps provided on the site shall be new and of the same shipment.

#### 2.1.5. Warranty: All lamps and luminaires shall have minimum five (5) year warranty.

#### 2.1.6. LED Lamps

- .1 Unless otherwise specified LED Luminaire Minimum Luminaire Efficacy 70 lumens/watt per IES LM-79.
- .2 LED Luminaire photometric performance and useful in-situ operating life expectations shall be based upon: LM-79 photometric test re-ports, associated supporting documentation for the LED devices used in the luminaire and calculations and supporting

---

test data estimating lumen maintenance for the luminaire.

- .3 Unless otherwise specified Correlated Colour Temperature (CCT) to be 3,500K, with nominal CCT tolerances in accordance with ANSI C78.377
- .4 Color Maintenance The change of chromaticity over the minimum lumen maintenance test period (6000 hours) shall be within 0.007 on the CIE 1976 (u',v') diagram.
- .5 Unless otherwise specified minimum CRI (R a) of 70. In addition, the R 9 value must be greater than 0.
- .6 Unless otherwise specified LED lumen Maintenance (LM  $\geq$  70% lumen maintenance (L 70) at 25,000 hours of operation: performance measured using the IES LM-80 and IES TM-21 protocols or based on 6,000 hours of luminaire testing, using a pass/fail threshold for lumen maintenance compliance as established by the Energy Star Manufacturer's Guide.

## 2.2. LED BALLASTS/DRIVER DATA

- 2.2.1. Where called for in the Lighting Fixture Schedule, provide ballasts or drivers for light fixtures. Contractor and luminaire manufacture is responsible for coordination of ballast/driver compatibility with specified luminaires.
- 2.2.2. All ballasts and drivers shall be in accordance with the latest version of the Local Electrical Code and any applicable codes and regulations.
- 2.2.3. Ballasts shall comply with limits governing electromagnetic and radio frequency interference and shall not interfere with operation of other normal electrical equipment.
- 2.2.4. Ballasts and Drivers shall meet all applicable ANSI and IEEE standards regarding harmonic distortion and surge protection.
- 2.2.5. Fluorescent ballasts shall not be affected by lamp failure and shall yield normal lamp life.
- 2.2.6. Unless otherwise noted dimming drivers and ballasts shall be capable of dimming to 5% or lower.
  - .1 Contractor to verify that dimming drivers specified are compatible with associated control protocol(s) used on each respective dimming system or zone. These system(s) or Zone(s) could include but are not limited to:
    - .1 0-10V
    - .1 DALI
- 2.2.7. Each fluorescent luminaire installed on branch circuits with voltages exceeding 150 volts-to-ground, shall be:
- 2.2.8. Provided with a disconnecting means integral with the luminaire that simultaneously opens all circuit conductors between the branch circuit conductors and the conductors supplying the ballast(s); and marked in a conspicuous, legible, and permanent manner adjacent to the disconnecting means, identifying the specific purpose.
- 2.2.9. LED Driver
  - .1 LED driver/power supply shall be dimmable via DALI, 0-10v, ELV, or MLV dimmers.
  - .2 Power factor - For LED engines >5W, must be  $\geq$  0.90
  - .3 Electro-magnetic and Radio Frequency Interference - Integral LED lamps must meet the appropriate FCC requirements for consumer use (FCC 47 CFR Part 15).
  - .4 Audible Noise - Integral lamp shall have a Class A sound rating.

- 
- .5 Integral LED lamps must meet the requirements of ANSI/UL 1993 – 2009
  - .6 Voltage fluctuation tolerance is  $\pm 10\%$ .
  - .7 Total harmonic distortion  $\leq 20\%$ .
  - .8 LED Operating temperature is  $-20^{\circ}\text{C}$  to  $+40^{\circ}\text{C}$ .

### 2.3. LENSES

2.3.1. Lenses shall be manufactured from injection molded clear acrylic.

2.3.2. Lenses shall be as follows unless otherwise noted:

- .1 A125 generic brand.
- .2 Pattern No. 12 standard
- .3 Nominal 0.125" thick.

### 2.4. FINISHES

2.4.1. Baked enamel finish:

- .1 Conditioning of metal before painting:
  - .1 For corrosion resistance conversion coating to ASTM F1137.
  - .2 For paint base, conversion coating to ASTM F1137.
- .2 Metal surfaces of luminaire housing and reflectors finished with high gloss baked enamel, polyester powdercoat or alzak aluminum to give smooth, uniform appearance, free from pinholes or defects.
- .3 Reflector and other inside surfaces finished as follows:
  - .1 White, minimum reflection factor 85%.
  - .2 Colour fastness: yellowness factor not above 0.02 and after 250 hours exposure in Atlas fade ometer not to exceed 0.05.
  - .3 Film thickness, not less than 0.03 mm average and in no areas less than 0.025 mm.
  - .4 Gloss not less than 80 units as measured with Gardner 60° gloss meter.
  - .5 Flexibility: withstand bending over 12 mm mandrel without showing signs of cracking or flaking under 10 times magnification.
  - .6 Adhesion: 24 mm square lattice made of 3 mm squares cut through film to metal with sharp razor blade. Adhesive cellulose tape applied over lattice and pulled. Adhesion satisfactory if no coating removed.

2.4.2. Alzak finish:

- .1 Aluminium sheet fabricated from special aluminum alloys and chemically brightened, subsequently anodically treated to specifications established by Alcoa, to produce:
- .2 Finish for mild commercial service, minimum density of coating 7.8 g/m<sup>2</sup>, minimum reflectivity 83% for specular, 80.5% for semi specular and 75% for diffuse.
- .3 Finish for regular industrial service, minimum density of coating 14.8 g/m<sup>2</sup>, minimum reflectivity 82% for specular and 73% for diffuse.
- .4 Finish for heavy duty service, minimum density of coating 21.8 g/m<sup>2</sup>, minimum reflectivity 85% for specular, 65% for diffuse.

2.5. LIGHTING CONTROL

2.5.1. Lighting control modules to be Lutron. Provide lighting control as identified on the drawings.

2.5.2. Submittals to include for all devices, accessories and finishes for the intended design. Submittals to include for zoning and sequence of operations where applicable.

2.6. INSTALLATION

2.6.1. Locate and install equipment in accordance with manufacturer's recommendations and as indicated.

2.6.2. Program the devices as per manufacturer's recommendations. Provide training for the university operations staff on re-programming of the system.

2.7. TESTS

2.7.1. Commission the system with manufacturer's representative at the presence of a representative from the university and Engineer.

2.7.2. Actuate control units in presence of Consultant to demonstrate lighting circuits are controlled as designated.

2.7.3. Demonstrate the operation of the system through the computer software and the BAS system.

END OF SECTION 26 50 00.00





# UTSC Cable Systems Specification

UTSC Information and Instructional Technology Services (I&ITS)

**Version 4.1**  
November 2024

---

**UTSC Standards:** Renovations & New Construction

**University of Toronto Scarborough**  
1265 Military Trail, Toronto, ON. Canada, M1C 1A4

**Revisions History**

Version Number	Version Date	Affected Sections																			
		2	3	4	5	6	7	8	9	10	11	12	13	14	15	16	17	18	19	20	
		27 05 13	27 05 26	27 05 29	27 05 33	27 05 36	27 05 53	27 05 55	27 11 16	27 11 19	27 11 23	27 11 26	27 13 13	27 13 13 13	27 13 23	27 13 23 13	27 15 01 16	27 15 01 19	27 15 43	27 16 19	
V 4.0	September 2022	✓	✓	✓	✓	✓	✓	✓	✓	✓	✓	✓	✓	✓	✓	✓	✓	✓	✓	✓	
V 4.1	November 2024			✓				✓				✓					✓			✓	

## **1 PART 1- GENERAL**

### **1.1 WORK INCLUDED**

- 1.1.1 Comply with the General requirements and documents referred to within.
- 1.1.2 To be read in conjunction with associated electrical and communication specification sections.
- 1.1.3 The contractor should seek clarification from the UTSC I&ITS Designate on site conditions and on any technical, work and/or premises-related questions without delay.

### **1.2 RELATED DOCUMENTS**

- 1.2.1 Drawings and general provisions of the contract, including general and supplementary conditions apply to this section. Refer to the following for additional information.
- 1.2.2 27 05 26 Grounding and Bonding for Communications Systems
- 1.2.3 27 05 29 Hangers and Supports for Communication Systems
- 1.2.4 27 05 33 Conduits and Back Boxes for Communication Systems
- 1.2.5 27 05 36 Cable Trays for Communication Systems
- 1.2.6 27 05 53 Identification for Communication Systems
- 1.2.7 27 15 55 Testing for Communication Services
- 1.2.8 27 11 16 Communication Cabinets, Racks, Frames and Enclosures
- 1.2.9 27 11 19 Communication Termination Blocks and Patch Panels
- 1.2.10 27 11 23 Communications Cable Management and Ladder Rack
- 1.2.11 27 11 26 Communications Rack Mounted Power and Power Strips
- 1.2.12 27 13 13 Communications Copper Backbone Cabling
- 1.2.13 27 13 13 13 Communications Copper Cable Splicing and Terminations
- 1.2.14 27 13 23 Communications Optical Fiber Backbone Cabling
- 1.2.15 27 13 23 13 Communications Optical Fiber Splicing and Terminations
- 1.2.16 27 15 01 19 Data Communications Horizontal Cabling
- 1.2.17 27 15 43 Communication Faceplates and Connectors
- 1.2.18 27 16 19 Communication Patch Cords and Cross Connect Wire

### **1.3 QUALITY ASSURANCE**

- 1.3.1 The contractor shall be certified, along with all technicians who should be properly trained by the manufacturer of a proposed cabling solution, with proof of certification readily available upon request.
- 1.3.2 Only new products listed in this document may be used unless otherwise submitted for approval.
- 1.3.3 The bidder shall demonstrate proven expertise in the implementation of network cabling.

### **1.4 SCOPE**

- 1.4.1 The contractor shall be responsible for the complete supply and installation of the following where required:
- 1.4.2 Communication basket cabling trays, supporting and installation hardware.
- 1.4.3 Horizontal Cabling: always consult with the UTSC I&ITS Designate before procuring materials. Cabling in existing installations may follow legacy standards. New installations will follow Cat 6 standards, including faceplates, jacks, patch cords, patch panels, etc.
- 1.4.4 Cabinets and data racks along with associated hardware.
- 1.4.5 Grounding of cable trays and data racks/cabinets.
- 1.4.6 Copper and fiber backbone cabling including all components for a complete end to end system.
- 1.4.7 Testing of all data, and backbone fiber cabling.
- 1.4.8 Contractor to make all necessary preparations, allowances and precautions to comply with the labor requirements for the job site to ensure that there will not be any disruption of work arising from the successful bidders work or workers.

### **1.5 GENERAL STIPULATIONS**

- 1.5.1 The contractor shall furnish all labor, materials, tools and other equipment necessary to provide a complete horizontal and backbone (copper and fiber) cabling system.
- 1.5.2 The contractor shall be responsible for the completion of all work included in the contract and shall employ certified, skilled technicians as necessary to satisfy all work and trades.



- 
- 1.5.3 The contractor shall carefully review all drawings (architectural, mechanical, electrical and communications) associated with the project and carry out the work so as not to delay or interfere with other trades.
  - 1.5.4 The contractor must comply with all requirements of the Occupational Health & Safety Act.
  - 1.5.5 The contractor shall provide all necessary permits to carry out their work.
  - 1.5.6 Local codes shall take precedence over the drawings and specifications, except where the contract documents are more stringent, then the contract documents shall apply.
  - 1.5.7 When the installation of the cabling system is completed and ready for acceptance the UTSC I&ITS Designate shall inspect all components before enabling the ports
  - 1.5.8 All testing and retesting shall be done at the contractor's expense.
  - 1.5.9 Contractor to provide cable test results 10 (ten) business days prior to the cutover to the UTSC I&ITS Designate for review.
  - 1.5.10 A DRAFT network drawing, detailing physical port locations, quantities and identifications must be provided ahead of time for I&ITS Network Engineering to configure network equipment.
  - 1.5.11 Contractor to provide a finalized network drawing reflecting the cable tray routing and all data drop labels. A network drawing is similar to, but less complex than, an as-built drawing. Its sole purpose is to depict the physical locations of each network wall jack and its associated label on a floor plan.

## **1.6 FIRE STOPPING**

- 1.6.1 The contractor shall seal all openings, new and/or old, they have utilized in floors, ceilings and partitions after all cabling has been completed. The fire stopping system and materials used shall comply with all applicable codes and conform to the acceptable testing methods and current standards in Canada, including, but not limited to, ULC-S115 and CAN/ULC-S101. The acceptability by ULC and by local authorities having jurisdiction, should be confirmed by the contractor to ensure that the test procedures were performed to ULC-S115 and CAN/ULC-S101.
- 1.6.2 The non-permanent intumescent and systems used for sealing the openings shall have a fire rating equal to or greater than the fire rating of the floor/wall/partition assemblies



being penetrated. The contractor shall be responsible for confirming the fire rating of the different assemblies to be penetrated with the UTSC designate and for ensuring the use of the proper fire proofing methods accordingly.

- 1.6.3 Provide a non-permanent intumescent or hybrid fire stop system to cap all empty conduit ends, ducts, sleeves and slots, meeting or exceeding the requirements of 1.6.1.
- 1.6.4 Provide a non-permanent intumescent or hybrid fire stop system around all cabling to seal the conduit, cable tray, ducts, sleeves and slot openings, re-sealable with minimal risk of damage to cables, meeting or exceeding the requirements of 1.6.1
- 1.6.5 A non-permanent intumescent or hybrid fire stop system will be used, as per 1.6.3-1.6.4 even when conduits, ducts, sleeves or slots are filled to maximum capacity.
- 1.6.6 Firestopping materials/systems used to fill voids in floors having openings greater than 100 mm in diameter, and which are accessible to the public, shall support floor design loading
- 1.6.7 The contractor shall furnish all labour, materials, tools and other equipment necessary to provide a complete fire stopping system
- 1.6.8 The contractor shall provide data sheets and applicable documentation for the fire stopping systems to be used and to demonstrate that the systems meets or exceeds the requirements of 1.6.1 & 1.6.2 prior to supply, installation and/or construction.

## **1.7 SCHEDULE OF WORK**

- 1.7.1 The contractor shall submit a schedule of work to be approved by the UTM I&ITS Designate. The schedule shall clearly indicate the proposed order in which the various activities will be undertaken and the estimated time required for the completion of the various activities.
- 1.7.2 The schedule of work may be revised periodically during the course of the project and must be approved by the UTSC I&ITS Designate.

## **1.8 CLEAN-UP**

- 1.8.1 The working space, telecommunications rooms and office spaces must be swept and free of unused cables, cable clippings, cardboard boxes or any other debris produced by the contractor, on a daily basis, by the end of each day, or as needed during the course of the day. The contractor is responsible for removing all trash to outside garbage containers at least once a day. The contractor shall provide a complete clean-up of the rooms at the end of the project or MAC work activity.
  - 1.8.2 Workstation outlet location areas shall be cleaned on an on-going basis each time the contractor completes any MAC work activity in the area.
  - 1.8.3 Costs associated for keeping the areas clean are the responsibility of the contractor.
-

- 1.8.4 Cleanliness of the site to be governed by the General Contractor/Construction Manager who may, after proper notice, back charge the contractor for site clean-up.

## **1.9 DELIVERY AND STORAGE**

- 1.9.1 Delivery and receipt of project materials shall be the sole responsibility of the contractor to receive, move, secure and store all equipment and material. All delivery costs are to be included in the contractor's proposal.
- 1.9.2 All cable to be used in the project shall be stored according to manufacturer's recommendations. In addition, all cable must be stored in a protected area. If cable is stored outside, it must be covered with opaque plastic or canvas for protection from the elements, with adequate ventilation to prevent condensation. If air temperature at the cable storage location will be below 4.4 °C (40 °F), the cable shall be moved to a heated location [minimum 10 °C (50 °F)]. If necessary, cable shall be stored off-site at the contractor's expense.

## **1.10 PROJECT/SITE CONDITION**

- 1.10.1 All bidders to arrange to obtain all necessary or referenced drawings and documents.
- 1.10.2 The contractor is responsible for seeking clarification with the UTM I&ITS Designate on how to address site and technical issues that may arise due to unforeseen difficulties. The contractor is not to operate under assumptions and make design changes without prior approval of the UTSC I&ITS Designate. Whenever necessary, clarification must be sought every time unpredictable difficulties arise, from start to completion of a project.
- 1.10.3 No claim for additional payment to be made for extra material or work made necessary by circumstances encountered due to conditions which were made visible upon, or reasonably inferable from thorough examination and review of all associated project documents, drawings and systems, prior to the submission of the response.
- 1.10.4 No claim for additional payment to be made for extra material or work made necessary by circumstances encountered due to conditions which were made visible upon visit to premises. The contractor must be abundantly experienced to infer material and workmanship required to carry out work performed both within visible and obstructed, hidden and underground locations. Such assessment is to be performed prior to the submission of the response
- 1.10.5 During the implementation phase of a project, the contractor is not to deviate, willingly or due to misunderstanding of documentation, from the specifications, diagrams and project documents provided by the UTSC I&ITS Designate. Doing so will require immediate corrective action by the contractor and additional costs incurred in order to



match the implementation with the design and specifications of the project will be done without hesitation at the contractor's expenses.

- 1.10.6 The cable routing diagrams only depict the cable routing and cable connectivity requirements. They are not installation drawings. Make all necessary allowances in the bid price to achieve the intent of the drawings.

### **1.11 CUTTING AND PATCHING**

- 1.11.1 Complete all cutting and patching required for the installation of the infrastructure.
- 1.11.2 In existing work and work already finished, cutting, patching and painting will be required by the contractor.
- 1.11.3 Be aware of fire rated partitions and return all services to the condition encountered before start of the work.

### **1.12 SITE RESPONSIBILITIES**

- 1.12.1 All pull strings present at the beginning of the installation must be returned or replaced to the initial state at the end of the communications cabling installation.
- 1.12.2 Do all cutting and patching required for the installation of the infrastructure.
- 1.12.3 The client is not responsible or liable for any missing material and/or tools belonging to the contractor.
- 1.12.4 The contractor is responsible for the removal and re-installation of all ceiling/floor tiles in the areas affected by its work. This is to be completed on a daily basis for the areas affected.
- 1.12.5 Any damage to ceiling tiles during the completion of any work outlined in this document is the responsibility of the contractor. Damage includes breaking, chipping or smudging. The decision with respect to any damage will be made by the General Contractor, Project Manager and the client.
- 1.12.6 The contractor is responsible for the storage and protection of the floor/ceiling tiles that are removed for cable installation.
- 1.12.7 Cabling that is not terminated on both ends, must not, under any circumstances, be abandoned in place. At the completion of work, the contractor is responsible for end-to-end removal of dead and unterminated cables from existing conduits, raceways, fittings, cable trays, wiring troughs and any other apparatus used to protect and route cables. Great care should be taken during the removal process so as to protect the existing live cables from damage.



### **1.13 TERMS AND CONDITIONS**

- 1.13.1 All terms and conditions of the specifications, bid documents and accompanying drawings to be strictly adhered to by the contractor, unless otherwise noted.
- 1.13.2 Any inability to comply with these requirements must be stated in writing, in detail with the response submission. Otherwise, it will be understood that the contractor is bound to the compliance with the stated terms and conditions.
- 1.13.3 Contractor to comply with the G.C. construction and installation schedule.
- 1.13.4 Do not assign or sub-contract any work without prior written consent from the IT department and or communication consultant.
- 1.13.5 Perform the complete installation in accordance with the latest editions of the Ontario and National Building Codes along with any other governing authorities of competent jurisdiction.

### **1.14 COORDINATION**

- 1.14.1 Coordinate telecommunications work with that of the other trades.
- 1.14.2 Contractor to review any interference between general construction, telecommunications, architectural, mechanical, electrical, structural, and other specialty trades involved and bring it to the attention of the G.C.

### **1.15 EQUIPMENT IDENTIFICATION**

- 1.15.1 All telecommunication equipment such as cabinets, racks and similar items shall be identified with labels which, ideally, should not exceed 8cm in length and 4cm in height.
- 1.15.2 Coordinate telecommunications work with that of the other trades.

### **1.16 WARRANTY**

- 1.16.1 Contractor shall warrant the materials and workmanship used in the installation of this project. Components must be covered by a manufacturer's warranty against defects in material and workmanship for a period of at least 25 years from the date test results are submitted to the manufacturer and approved by UTSC
  - 1.16.2 All cabling system will meet or exceed the UTP channel transmission requirements specified by ANSI/TIA 568-D.
  - 1.16.3 Contractor shall provide all material and labour to make any deficiencies due to faulty materials or workmanship which become apparent within a one-year period.
  - 1.16.4 All terminated horizontal cabling runs shall be 100% tested for defects in installation. Cabling system performance under installed conditions should comply to the requirements found in the TIA/EIA-568-C series of standards. All pairs in each installed cable shall be verified prior to system acceptance. Any defect in the cabling system
-



installation, including (but not limited to) cables, connectors, and cordage shall be repaired or replaced in order to ensure 100% usability of all installed cable runs.

- 1.16.5 The communications contractor shall submit the test results for the project to the UTSC I&ITS Designate 10 (ten) business days prior to the cutover, as indicated in 1.5.9.
- 1.16.6 Upon completion of the testing by the contractor for any MAC work, the contractor shall submit to the UTSC I&ITS Designate the network drawing, including cable ID numbers related to the cabling completed for the project, 10 (ten) business days prior to the cutover, as indicated in 1.5.10.
- 1.16.7 Failure to provide test results upon request will require the contractor to retest all horizontal and or backbone cabling related to the project and any MAC work with no cost to the client.

### **1.17 SUBMISSIONS**

- 1.17.1 The contractor shall provide product data and shop drawings for all materials proposed for installation under this contract. The product data and shop drawings shall be submitted to the UTSC I&ITS Designate for approval before such equipment is purchased and or delivered to the site.
- 1.17.2 Review all aspects of the specifications and drawings and identify any and all issues for inclusion in the contract documents examination report.
- 1.17.3 This section contains the definitions, acronyms and abbreviations that have special technical meaning or are unique to the technical content of this document.

### **1.18 STANDARDS**

- 1.18.1 The design considerations, and installation guidelines provided in this document are in part derived from recommendations found in recognized telecommunications industry standards. The following are used as guidelines.

#### **Spaces and Pathways**

TIA-569-B– Commercial Building Standard for Telecommunications Pathways and Spaces.

#### **Grounding**

ANSI-J-STD-607-B – Commercial Building Grounding (Earthing) and Bonding Requirements for Telecommunications.

#### **Cabling Systems**

ANSI/TIA 568-C.0 Generic Telecommunications Cabling for Customer Premises.

ANSI/TIA 568-C.1 Commercial Building Telecommunications Cabling Standard.

---



ANSI/TIA 568-C.2 Balanced Twisted-Pair Telecommunications Cabling and Components Standards.

ANSI/TIA 568-C.3 Optical Fibre Cabling Components Standard.

### **Cabling Administration**

TIA/EIA-606-B – Administration Standard for Commercial Telecommunications Infrastructure

### **Networking**

IEEE Standard 802.3an (2006) – 10GBASE-T

### **Design**

BICSI Telecommunications Distribution Methods Manual (TDMM) – 13th edition.

### **Installation**

BICSI Information Transport Systems Installation Manual (ITSIMM) – 6th edition.

## **1.19 DEFINITIONS**

- 1.19.1 This section contains the definitions, acronyms and abbreviations that have special technical meaning or are unique to the technical content of this document.
  - 1.19.2 **Above Finished Floor (AFF)** - Standard mounting height (e.g. 12-inch AFF) for a device using the centre line of the device as the measuring point.
  - 1.19.3 **Backbone** - A facility (e.g. pathway, cable or conductors) between the telecommunications room and the main telephone room.
  - 1.19.4 **Bonding** - The permanent joining of metallic parts to form an electrically conductive patch that will assure electrical continuity and the capacity to conduct safely any current likely to be imposed on it.
  - 1.19.5 **Cable** - An assembly of one or more conductors or optical fibres within a sheath, constructed so as to permit use of conductors singly or in groups.
  - 1.19.6 **Entrance Room** - A space in which the joining of inter or intra-building telecommunications backbone facilities takes place. An entrance room may also serve as the equipment room
  - 1.19.7 **Horizontal Cabling** - Portion of the cabling system that extends from the work area outlet, through the cabling in the wall/ceiling/floor and then to the patch panel in the telecommunications room. The system also includes the patch cords at the work area outlet, and patch cords in the telecommunications room.
  - 1.19.8 **Intra-building Backbone** - A backbone network providing communications within the building.
-



- 1.19.9 **Inter-building Backbone** - A backbone network providing communications for more than one building.
- 1.19.10 **Patch Panel** - A cross connect system of connectors that can be mated together to facilitates administration of a cabling system.
- 1.19.11 **Pathway** - A facility for the placement of telecommunication cabling.
- 1.19.12 **Patch Cord** - A length of copper or fibre cable with connectors on each end to be used to join telecommunications circuits/links at the cross-connects. Copper cables will usually, but not always, be of Cat 6A grade. **The UTSC I&ITS Designate must be consulted before materials are procured.**
- 1.19.13 **Telecommunications Room (TR)** - An ample space in which the end of horizontal cabling is terminated in data racks. It connects to another TR or to the MTR for intra-building data and voice communication. The facility must be clean, dust-free and include proper air handling to regulate temperature and moisture in order to prevent the lifespan reduction of the equipment.
- 1.19.14 **Main Telecommunications Room (MTR)** - An ample space in which the end of horizontal and backbone cabling are terminated in data racks. It is also a TR and is usually the node assigned for inter-building data and voice communication. The facility must be clean, dust-free and include proper air handling to regulate temperature and moisture in order to prevent the lifespan reduction of the equipment.
- 1.19.15 **Telecommunications Grounding Busbar (TGB)** - A common point of connection for the telecommunications system and bonding to ground. It is located in the telecommunications room.
- 1.19.16 **Telecommunications Main Grounding Busbar (TMGB)** - A common point of connection for the telecommunications system and bonding to ground. It is located in the main telecommunications room.
- 1.19.17 **Wireless Access Point (WAP)** - The central or control point in a wireless cell that acts as a link for data traffic to and from the wireless devices in the cell.

## 1.20 ACRONYMS AND ABBREVIATIONS

ACR	Attenuation-to Crosstalk Ratio
ANSI	American National Standards Institute
AWG	American Wire Gauge
BC	Building Conductor
BICSI	Building Industry Consulting Service International
BTU	British Thermal Unit
CATV	Community Antenna Television (cable television)
CCTV	Closed Circuit Television
CSA	Canadian Standards Association
CT	Cable Tray
dB	Decibel

---



DSL	Digital Subscriber Line
DSU	Digital Service Unit
EMT	Electrical Metallic Tubing
EP	Entrance Point
FOTP	Fibre Optic Test Procedure
Ga	Gauge
Gb	Gigabit
HC	Horizontal Cross-connect
HVAC	Heating, ventilating and air conditioning
Hz	Hertz
IC	Intermediate cross-connect
LAN	Local Area Network
MTR	Main Telecommunications Room
NIC	Network Interface Card
OSP	Outside Plant
OTDR	Optical Time Domain Reflectometer
PB	Pull Box
PE	Polyethylene
RF	Radio Frequency
RFI	Radio Frequency Interference
RMC	Rigid Metal Conduit
SM	Single-mode
TBB	Telecommunications Bonding Backbone
TBBIBC	Telecommunications Bonding Backbone Interconnecting Bonding Connector
UPS	Uninterruptible Power Supply
WAP	Wireless Access Point

## **2. PART 2 - PRODUCTS**

### **2.1. NOT USED**

## **3. PART 3 - EXECUTION**

### **3.1. NOT USED**

**END OF SECTION**

---

## **1 PART 1- GENERAL**

### **1.1 WORK INCLUDED**

- 1.1.1 Comply with the General requirements and documents referred to within.
- 1.1.2 Provide labour, materials, products, equipment and services to complete the grounding and bonding for communications systems work specified within.
- 1.1.3 To be read in conjunction with associated electrical and communication specification sections.
- 1.1.4 The contractor should seek clarification from the UTSC I&ITS Designate on site conditions and on any technical, work and/or premises-related questions without delay.

### **1.2 RELATED DOCUMENTS**

- 1.2.1 Drawings and general provisions of the contract, including general and supplementary conditions apply to this section. Refer to the following for additional information.
- 1.2.2 27 05 13 Communication Services
- 1.2.3 27 05 29 Hangers and Supports for Communications Systems
- 1.2.4 27 05 33 Conduits and Back Boxes for Communication Systems
- 1.2.5 27 05 36 Cable Trays for Communication Systems
- 1.2.6 27 11 16 Communication Cabinets, Racks, Frames and Enclosures
- 1.2.7 27 11 19 Communication Termination Blocks and Patch Panels
- 1.2.8 27 11 23 Communications Cable Management and Ladder Rack
- 1.2.9 27 11 26 Communications Rack Mounted Power and Power Strips
- 1.2.10 27 13 13 Communications Copper Backbone Cabling
- 1.2.11 27 13 13 13 Communications Copper Cable Splicing and Terminations
- 1.2.12 27 13 23 Communications Optical Fibre Backbone Cabling
- 1.2.13 27 13 23 13 Communications Optical Fibre Splicing and Terminations
- 1.2.14 27 15 01 16 Voice Communications Horizontal Cabling
- 1.2.15 27 15 01 19 Data Communications Horizontal Cabling
- 1.2.16 27 15 43 Communication Faceplates and Connectors
- 1.2.17 27 16 19 Communication Patch Cords and Cross Connect Wire

### 1.3 REFERENCES

- 1.3.1 Comply with the latest addition of the following applicable specifications and standards except as otherwise shown or specified.
- 1.3.2 Underwriters Laboratories, Inc (UL).
- 1.3.3 ANSI/TIA 607 requirements (current version including all addenda): Commercial Building Grounding and Bonding Requirements for Telecommunications.

### 1.4 QUALITY ASSURANCE

- 1.4.1 All materials, equipment and parts comprising the unit's specified within this document shall be new and unused and of a current manufacture.
- 1.4.2 Only new products and applications listed in this section may be used unless otherwise submitted for approval.

### 1.5 SYSTEM DESCRIPTION

- 1.5.1 The main entrance facility/equipment room shall be equipped with a TMGB. The TMGB shall be connected to the building electrical entrance grounding facility. In all other telecommunications rooms there is to be a TGB; these are to be connected back to the TMGB through appropriately sized copper conductors that form the TBB.
- 1.5.2 An electrical engineer is to provide the correct sizing of the ground wire for 1.5.1. Conductors shall be sized according to distance and must be stranded copper with green insulation.
- 1.5.3 In each telecommunications room provide #6 AWG stranded copper with green insulation from the TGB to all metallic components (cable trays, racks and all other enclosures). No serial connections are acceptable.
- 1.5.4 The TMGB must meet ANSI/TIA 607 requirements for network system grounding applications. Must be made of high conductivity copper and tin-plated to inhibit corrosion. Minimum bar size must be 4"W x 1/4"H x 12"L with insulators and standoffs. Must be pre-drilled, complete with 12 x 1/4" stud holes with 5/8" hole spacing and 6 x 3/8" stud holes with 1" hole spacing.
- 1.5.5 The TGB must meet ANSI/TIA 607 requirements for network system grounding applications. Must be made of high conductivity copper and tin-plated to inhibit corrosion. Minimum bar size must be 2"W x 1/4"H x 12"L with insulators and standoffs. Must be pre-drilled, complete with 6 x 1/4" stud holes with 5/8" hole spacing and 3 x 3/8" stud holes with 1" hole spacing.
- 1.5.6 The contractor must visually inspect the Grounding and Bonding System for loose connections. A potential difference test must be made between the TMGB and electrical ground, and between the TMGB and each TGB. All test measurements must comply with the ANSI/TIA 607 requirements.

## **1.6 SUBMITTALS**

- 1.6.1 Shop drawing to reflect the type and size of the TMGB and the TGB for review.
- 1.6.2 Provide a ground test report in compliance with the ANSI/TIA 607 requirements.

## **2 PART 2- PRODUCTS**

### **2.1 ACCEPTABLE MANUFACTURERS**

- 2.1.1 Thomas and Betts, Chatsworth Products Inc., Burndy, Panduit or approved equal.

## **3 PART 3- EXECUTION**

### **3.1 INSTALLATION**

- 3.1.1 Bond all telecommunication cable trays, data cabinets, data racks and all other metallic communication infrastructure components to the nearest TMGB or TGB using a minimum of a #6 AWG stranded, green insulated conductor and appropriate 2-hole, long barrel, window lug.
- 3.1.2 Contractor to ensure that the data rack and/or cabinet grounding does not block and/or interfere with any rack mount units in the racks and/or cabinets.
- 3.1.3 Racks and/or cabinets are to be grounded at their top the TMGB or TGB.
- 3.1.4 Bonding connectors shall be continuous and routed in the shortest straight path. Any bends placed in the connector shall be sweeping bends.
- 3.1.5 Provide a record of the ground resistance measurements from the ground bus to earth.
- 3.1.6 Furnish all test results to be reviewed by an electrical engineer.
- 3.1.7 All installations must be performed by licensed unionized (IBEW) electricians/telecommunication technicians. The tradesperson must follow the latest safety requirements from the Ministry of Labour.
- 3.1.8 The contractor shall provide installers trained in the applicable codes, regulations and installation standards. Quality workmanship of the highest standard is expected to be delivered by the tradespersons. Acceptance of the work is subject to the approval of the university's designate and IT contact.

**END OF SECTION**

## **1 PART 1- GENERAL**

### **1.1 WORK INCLUDED**

- 1.1.1 Comply with the general requirements and documents referred to within.
- 1.1.2 Provide labour, materials, products, equipment and services to complete the hangers and supports for communications systems work specified within.
- 1.1.3 To be read in conjunction with associated electrical and communication specification sections.
- 1.1.4 The contractor should seek clarification from the UTSC I&ITS Designate on site conditions and on any technical, work and/or premises-related questions without delay.

### **1.2 RELATED DOCUMENTS**

- 1.2.1 Drawings and general provisions of the contract, including general and supplementary conditions apply to this section. Refer to the following for additional information.
- 1.2.2 27 05 13 Communication Services
- 1.2.3 27 05 26 Grounding and Bonding for Communications Systems
- 1.2.4 27 05 33 Conduits and Back Boxes for Communication Systems
- 1.2.5 27 05 36 Cable Trays for Communication Systems
- 1.2.6 27 05 53 Identification for Communication Services
- 1.2.7 27 05 55 Testing for Communication Services
- 1.2.8 27 11 16 Communication Cabinets, Racks, Frames and Enclosures
- 1.2.9 27 11 19 Communication Termination Blocks and Patch Panels
- 1.2.10 27 11 23 Communications Cable Management and Ladder Rack
- 1.2.11 27 11 26 Communications Rack Mounted Power and Power Strips
- 1.2.12 27 13 13 Communications Copper Backbone Cabling
- 1.2.13 27 13 13 13 Communications Copper Cable Splicing and Terminations
- 1.2.14 27 13 23 Communications Optical Fibre Backbone Cabling
- 1.2.15 27 13 23 13 Communications Optical Fibre Splicing and Terminations
- 1.2.16 27 15 01 16 Voice Communications Horizontal Cabling
- 1.2.17 27 15 01 19 Data Communications Horizontal Cabling
- 1.2.18 27 15 43 Communication Faceplates and Connectors
- 1.2.19 27 16 19 Communication Patch Cords and Cross Connect Wire

### **1.3 QUALITY ASSURANCE**

- 1.3.1 Only new products and applications listed in this section may be used unless otherwise submitted for approval.

### **1.4 SYSTEM DESCRIPTION**

- 1.4.1 Hangers and supports are to be supplied and installed as per this document and drawings to support the various cabling from the workstation to the overhead cable tray or to the MTR and/or TR locations.

### **1.5 SUBMITTALS**

- 1.5.1 Shop drawings for each type of product indicated in the following document, including construction details, material descriptions, dimensions of individual components and profiles and finishes for the products listed. Include rated capacities, operating characteristics along with furnished specialties and accessories.

## **2 PART 2- PRODUCTS**

### **2.1 ADJUSTABLE CABLE SUPPORTS**

- 2.1.1 Shall only be used as a last resort if cable tray is not possible
- 2.1.2 Must be approved by UTSC I&ITS Designate if cable tray is not possible
- 2.1.3 Suitable for use in air handling spaces.
- 2.1.4 Allow for attachment to ceilings, beams, walls, threaded rods and underfloor supports.
- 2.1.5 Support a minimum cable capacity of 210 Cat 6.
- 2.1.6 Support a minimum static load of 46kg (100lbs).

### 3 PART 3- EXECUTION

#### 3.1 INSTALLATION

- 3.1.1 The horizontal cabling pathway shall be a self-supporting system.
- 3.1.2 Cable supports shall not be attached to ceiling grid support rods, conduits, water pipes HVAC ducts or lighting fixture wires.
- 3.1.3 The cable supports shall be installed no more that 1.5 meters (48") apart.
- 3.1.4 All cable supports shall be rated for a minimum of Cat 6 for the structured cabling infrastructure.
- 3.1.5 In a ceiling distribution design the cable supports shall be installed at a minimum of 36" clearance between the ceiling tile and the structured cabling pathway.
- 3.1.6 All hangers, rods and supports must be suspended from or attached to the structural steel, concrete slab and or walls with proper hardware designed to support their load bearing rating.
- 3.1.7 Only touch-fasteners (a.k.a. velcro fasteners) shall be used where required. Under no circumstances plastic zip ties and similar products shall be utilized.
- 3.1.8 Where support for horizontal cable is required, the contractor shall install appropriate sized cable supports to support the horizontal cabling listed in this document.
- 3.1.9 To minimize any possibility of disruption, maintain the following minimum clearances from electrical and heat sources when installing cable supports for the horizontal cabling pathway:

<i>CLEARANCES TABLE</i>	
Item	Minimum Clearance
Motor	1.2 m ( 4'-0" )
Transformers	1.2 m ( 4'-0" )
Conduit and cables used for electrical distribution less than 1kV	0.3 m ( 1'-0" )



Conduit and cables used for electrical distribution greater than 1kV	1.0 m ( 3'-0" )
Fluorescent Luminaires	12 cm ( 5" )
Pipes ( gas, oil, water, etc )	0.3 m ( 1'-0" )
HVAC ( equipment, ducts, etc	15 cm ( 6 " )

END OF SECTION

## **1 PART 1- GENERAL**

### **1.1 WORK INCLUDED**

- 1.1.1 Shall only be used as a last resort if cable tray in not possible
- 1.1.2 Must be approved by UTSC I&ITS Designate if cable tray is not possible
- 1.1.3 Provide labour, materials, products, equipment and services to complete the conduits and back boxes for communications systems work specified within.
- 1.1.4 To be read in conjunction with associated electrical and communication specification sections.
- 1.1.5 The contractor should seek clarification from the UTSC I&ITS Designate on site conditions and on any technical, work and/or premises-related questions without delay.

### **1.2 RELATED DOCUMENTS**

- 1.2.1 Drawings and general provisions of the contract, including general and supplementary conditions apply to this section. Refer to the following for additional information.
  - 1.2.2 27 05 13 Communication Services
  - 1.2.3 27 05 26 Grounding and Bonding for Communications Systems
  - 1.2.4 27 05 29 Hangers and Supports for Communication Systems
  - 1.2.5 27 05 36 Cable Trays for Communication Systems
  - 1.2.6 27 05 53 Identification for Communication Services
  - 1.2.7 27 05 55 Testing for Communication Services
  - 1.2.8 27 11 16 Communication Cabinets, Racks, Frames and Enclosures
  - 1.2.9 27 11 19 Communication Termination Blocks and Patch Panels
  - 1.2.10 27 11 23 Communications Cable Management and Ladder Rack
  - 1.2.11 27 11 26 Communications Rack Mounted Power and Power Strips
  - 1.2.12 27 13 13 Communications Copper Backbone Cabling
  - 1.2.13 27 13 13 13 Communications Copper Cable Splicing and Terminations
  - 1.2.14 27 13 23 Communications Optical Fibre Backbone Cabling
  - 1.2.15 27 13 23 13 Communications Optical Fibre Splicing and Terminations
  - 1.2.16 27 15 01 16 Voice Communications Horizontal Cabling
  - 1.2.17 27 15 01 19 Data Communications Horizontal Cabling
  - 1.2.18 27 15 43 Communication Faceplates and Connectors
  - 1.2.19 27 16 19 Communication Patch Cords and Cross Connect Wire
-

### **1.3 QUALITY ASSURANCE**

- 1.3.1 Only new products and applications listed in this section may be used unless otherwise submitted for approval.

### **1.4 SYSTEM DESCRIPTION**

- 1.4.1 The conduits and telecommunication boxes are to be supplied and installed as per this document and drawings to support the various cabling from the workstation to the overhead cable tray or to the MTR and/or TR locations.

### **1.5 SUBMITTALS**

- 1.5.1 Shop drawings for each type of product indicated in the following document, including construction details, material descriptions, dimensions of individual components and profiles and finishes for the products listed. Include rated capacities, operating characteristics along with furnished specialties and accessories.

## **2 PART 2- PRODUCTS**

### **2.1 CONDUIT**

- 2.1.1 All indoor conduits shall be thin wall EMT reamed and bushed at both ends.
- 2.1.2 The external surface of all visible indoor conduits shall be painted as to match colors already existing on the surrounding structure so as not to create an unpleasant view.
- 2.1.3 Conduits exposed to the weather, in wet locations, subject to mechanical injury, or in any hazardous locations or where required by code, shall be rigid threaded, galvanized steel conduit.
- 2.1.4 Joints in conduits installed underground, in concrete slab on grade or in a concrete duct bank shall be made completely watertight.

### **2.2 IN SLAB FLOOR BOXES**

- 2.2.1 All in slab floor boxes shall be constructed of galvanized steel and includes a lid assembly.
  - 2.2.2 Box equipped with conduit knockouts at each end and on each side for conduit feeds for data cabling and power.
  - 2.2.3 The lid to be available either recessed for carpet or tile or a flat flush lid.
  - 2.2.4 The lid shall have an open for the easy access for data patch cords and power cords.
-



- 2.2.5 The floor box shall be a minimum of 12" x 12" x 5" deep.
- 2.2.6 Joints in conduits installed underground, in concrete slab on grade or in a concrete duct bank shall be made completely watertight.
- 2.2.7 Minimum concrete thickness over or around a conduit in a concrete slab shall be 75mm (3").

### **2.3 METAL RACEWAY**

- 2.3.1 The single raceway shall be steel.
- 2.3.2 ScuffCoat scratch-resistant finish.
- 2.3.3 Resists oxidation, corrosion and fading.
- 2.3.4 Can be installed as recessed or surface.
- 2.3.5 Various types of fittings for horizontal and vertical pathways.
- 2.3.6 Use surface mount box for voice and data cabling.

## **3 PART 3- EXECUTION**

### **3.1 INSTALLATION**

- 3.1.1 The inside radius of a bend in a conduit shall be at least 10 times the internal diameter of the conduit.
  - 3.1.2 All zone conduits shall be identified and labelled at both ends. Tags shall identify the start and finish of conduit runs. Pull boxes shall be labelled on the exposed exterior.
  - 3.1.3 All conduits dedicated for the communication structured cabling system shall not be shared with other services.
  - 3.1.4 The telecommunication system shall be labelled green from end to end on conduits and at pull boxes.
  - 3.1.5 All conduits shall originate and be physically connected to the MTR, TR, backboards, cable tray and pull boxes.
  - 3.1.6 All fittings, connectors and couplings are to be steel.
  - 3.1.7 All conduits entering or exiting through the ceilings or walls of the MTR and or TR shall be installed to the basket cable tray in the room and stop 6" above the cable tray.
  - 3.1.8 All conduit runs shall follow the building grid lines and shall be concealed where possible.
  - 3.1.9 Unless otherwise specified, all conduit runs shall be a maximum of 30 meters (100 feet) in length with a maximum of two ninety-degree bends between pull boxes.
-



- 3.1.10 A pull box shall be placed in conduit runs where the sum of the bends exceeds 180 degrees, where the overall length of the conduit run is more than 30m, or if there is a reverse bend in the run.
- 3.1.11 In all instances pull boxes shall be placed in straight sections of a conduit run and shall not be used in lieu of a bend. Corresponding ends of the conduit are to be aligned with each other.
- 3.1.12 Conduit fittings or pull elbows fittings shall not be used in place of pull boxes or bends.
- 3.1.13 Pull boxes shall be installed at a reasonable height, in an exposed location and such that access for the installation of cables is not prohibited.
- 3.1.14 Pull boxes shall not be placed in a fixed false ceiling space, unless immediately above a suitably marked and hinged access panel.
- 3.1.15 Provide and install 25mm (1") diameter green dot decals on the ceiling T-bar rail showing location of pull box.
- 3.1.16 Pull boxes shall be constructed and sized in accordance with the Canadian Electrical Code and ANSI/TIA standards of gauge steel and shall have a rust resistant finish.
- 3.1.17 Place pull boxes in readily accessible locations only.
- 3.1.18 Locations and sizes of all pull boxes shall be indicated on the design submission.
- 3.1.19 Pull boxes shall be placed in straight sections of a conduit run and shall not be used in lieu of a bend. Corresponding ends of the conduit are to be aligned with each other. Conduit fittings or pull elbow fittings shall not be used in place of pull boxes or bends.
- 3.1.20 All conduits shall be installed in accordance with the Canadian Electrical Code, Part 1 Section 12, applicable building codes and in accordance with TIA/EIA 569-B.
- 3.1.21 The use of C, LB, LL, LR and T type fittings or elbows fittings is not permitted.
- 3.1.22 Conduits ending in the vicinity of a cable tray shall be terminated at a height of no less than 100mm (4") and no more than 150mm (6") from the top of the cable tray. Conduit runs shall not be punched through the side of the cable tray.
- 3.1.23 The minimum size (inside diameter) for EMT conduit running between the MTR and the telecommunications outlet location is twenty-five millimeters (25mm) (1").
- 3.1.24 The formulas below should be used to calculate the maximum number of UTP cables per conduit size, at a maximum 40% fill ratio. The ensuing chart provides an example for UTP cables (.288OD) in various conduit sizes.

- 3.1.25 Cable fill capacities of conduit, cable tray and raceways shall not be greater than 40%.
- 3.1.26 A pull cord or fish tape shall be installed in all conduits.
- 3.1.27 Conduit must enter the outlet boxes from the top or bottom.
- 3.1.28 The contractor is responsible for cleaning all conduits prior to pulling any cable.
- 3.1.29 The outlet boxes shall be installed in the locations identified on the drawing. The outlet box shall be installed at 300mm (12") AFF or at the same height and within 300mm (12") of the adjacent electrical duplex receptacles, unless otherwise noted on the drawings. Wherever possible, the face of the plastic ring should be installed flush with the finished wall.



- 3.1.30 Back to back outlet boxes shall not be used.
- 3.1.31 Outlet boxes must be equipped with a plaster ring to accommodate the installation of the multimedia faceplate.
- 3.1.32 Plaster rings will be specified as a single or double gang to accommodate cabling requirements.
- 3.1.33 Plaster rings or raised adapter plates shall not reduce the size of the outlet such that two additional outlets could not be added in the future.
- 3.1.34 In slab floor boxes are to be sized to reflect the total quantity of data cabling along with power requirements.
- 3.1.35 If AV cabling is to be combined with data cabling, the in slab floor box needs to be enlarged and reviewed by the IT department for approval.
- 3.1.36 Quality and workmanship shall be at the highest of professional tradesman levels to be accepted for completion.
- 3.1.37 To minimize any possibility of disruption, maintain the following minimum clearances from electrical and heat sources when installing the horizontal conduits for the horizontal cabling pathway:

<b>CLEARANCES TABLE</b>	
Item	Minimum Clearance
Motor	1.2 m ( 4'-0" )
Transformers	1.2 m ( 4'-0" )
Conduit and cables used for electrical distribution less than 1kV	0.3 m ( 1'-0" )
Conduit and cables used for electrical distribution greater than 1kV	1.0 m ( 3'-0" )
Fluorescent Luminaires	12 cm ( 5" )
Pipes (gas, oil, water, etc)	0.3 m ( 1'-0" )
HVAC (equipment, ducts, etc)	15 cm ( 6 " )

- 3.1.38 For concrete wall locations the single channel shall be used and properly secured to the block wall.



- 3.1.39 If more than two data cables are to be installed at a single location the metal raceway is to be sized to accommodate the total number of data cables using the 40% fill ratio.
- 3.1.40 At the faceplate location a surface wire mold box is to be connected using proper mounting hardware to install voice and data cabling in a communication faceplate.

**END OF SECTION**

## **1 PART 1- GENERAL**

### **1.1 WORK INCLUDED**

- 1.1.1 Comply with the General requirements and documents referred to within.
- 1.1.2 Provide labour, materials, products, equipment and services to complete the cable tray for communications systems work specified within.
- 1.1.3 To be read in conjunction with associated electrical and communication specification sections.
- 1.1.4 The contractor should seek clarification from the UTSC I&ITS Designate on site conditions and on any technical, work and/or premises-related questions without delay.

### **1.2 RELATED DOCUMENTS**

- 1.2.1 Drawings and general provisions of the contract, including general and supplementary conditions apply to this section. Refer to the following for additional information.
- 1.2.2 27 05 13 Communication Services
- 1.2.3 27 05 26 Grounding and Bonding for Communications Systems
- 1.2.4 27 05 29 Hangers and Supports for Communication Systems
- 1.2.5 27 05 33 Conduits and Back Boxes for Communication Systems
- 1.2.6 27 05 53 Identification for Communication Systems
- 1.2.7 27 05 55 Testing for Communication Services
- 1.2.8 27 11 16 Communication Cabinets, Racks, Frames and Enclosures
- 1.2.9 27 11 19 Communication Termination Blocks and Patch Panels
- 1.2.10 27 11 23 Communications Cable Management and Ladder Rack
- 1.2.11 27 11 26 Communications Rack Mounted Power and Power Strips
- 1.2.12 27 13 13 Communications Copper Backbone Cabling
- 1.2.13 27 13 13 13 Communications Copper Cable Splicing and Terminations
- 1.2.14 27 13 23 Communications Optical Fibre Backbone Cabling
- 1.2.15 27 13 23 13 Communications Optical Fibre Splicing and Terminations
- 1.2.16 27 15 01 16 Voice Communications Horizontal Cabling
- 1.2.17 27 15 01 19 Data Communications Horizontal Cabling
- 1.2.18 27 15 43 Communication Faceplates and Connectors
- 1.2.19 27 16 19 Communication Patch Cords and Cross Connect Wire

### **1.3 QUALITY ASSURANCE**

- 1.3.1 Comply with EIA/TIA 569-B Commercial Building Standard for Telecommunication Pathways and Spaces.
- 1.3.2 Only products and applications listed in this section may be used unless otherwise submitted for approval.

### **1.4 SYSTEM DESCRIPTION**

- 1.4.1 Provide an appropriate cable tray solution within the ceiling space of an area as indicated on the drawings.
- 1.4.2 Cable tray supports shall be installed at intervals of no more than 6 feet. At each interval, appropriate support (trapeze hangers, central hangers, cantilever arms) will be selected from the products listed in this document (Section 2) based on the following criteria:
  - 1.4.2.1 If the cable tray is to be installed on or against a wall, cantilevered arms shall be used to support the tray (see 2.3 of this document).
  - 1.4.2.2 If the ceiling area does not have enough clearance to accommodate two support rods per support point, a cable tray system based on the T-shape tray will be installed.
  - 1.4.2.3 In all other cases, a trapeze cable tray mounting method will be used. This is the least desirable solution and should be avoided.
- 1.4.3 Coordinate layout and installation of cable trays and their suspension system with other construction that penetrates ceilings or is supported by them, including all light fixtures, HVAC equipment, fire suppression system and partitions.
- 1.4.4 Cable tray systems should be designed and installed with adequate room around the cable tray to allow for the setup of cable pulling equipment. Also, space around the cable tray provides easy access for installation of additional cables or the removal of surplus cables. See subsection 3.1.12 for details.
- 1.4.5 Provide all fittings and miscellaneous hardware necessary to provide complete cable tray solution. Miscellaneous hardware includes, but is not limited to: coupling nuts, hex nuts, clamps, washers, bolts, hinges, splices, expansion joints and couplers.

### **1.5 SUBMITTALS**

- 1.5.1 Shop drawing to reflect the type, size and material finish of the cable tray for review.
  - 1.5.2 Provide fabrication and installation details of the cable trays along with all components and attachments including clamps, brackets, hanger rods, splice plate connectors, expansion joint assemblies, straight lengths and all fittings.
-

## **2 PART 2- PRODUCTS**

### **2.1 CABLE TRAYS**

- 2.1.1 Cable tray material must be Legrand Cablofil wire mesh cable tray
- 2.1.2 Straight sections shall be supplied in standard 10 foot (3.05m) lengths
- 2.1.3 All bends in cable tray, including 90°, 45° bends, and tee intersections shall be “radius bends” with a minimum internal bend radius of 5”.
  
- 2.1.4 Minimum height of cable tray for horizontal cabling is 2 inches.
- 2.1.5 Width of cable tray will be selected based on available clearance in selected cable tray pathway. Largest cable tray width available which still fits in selected pathway with appropriate clearance will be provided. For example, if the pathway is 25” wide, and minimum horizontal clearance is 10” on each side, then the maximum available width for cable tray is 5”. If cable tray is available in widths of 4”, 6”, and 8”, then 4” wide cable tray must be supplied and installed.
- 2.1.6 Minimum width of cable tray is 4 inches. If available space in a given pathway does not allow for a cable tray width of at least 4 inches, contractor shall report to the UTSC I&ITS Designate for further instructions.
  
- 2.1.7 Must conform to NEMA VE1 standards for load capacity.
- 2.1.8 Must be certified E-30 to E-90 for fire and heat resistance.

## **2.2 DROP OUTS**

- 2.2.1 Must be used anywhere cabling enters or exits the cable tray at an angle greater than 30°.
- 2.2.2 Must be compatible with existing or new cable tray (compatible fasteners & supports).

### **2.3 CABLE TRAY SUPPORTS – CENTRAL HANGERS**

- 2.3.1 Must be compatible with cable tray and allow for cable tray to be securely fastened to a wall.
- 2.3.2 Must be able to mount on  $\frac{3}{8}$ " threaded rod.
- 2.3.3 Must include protective sleeve around threaded rod to protect cables from friction damage.
- 2.3.4 Must be able to support between 68kg and 136kg (150 ~ 300 lbs) loads per span, based on width of cable tray:
  - 2.3.4.1 For cable width of 4", each support must support up to 68kg (150lbs).
  - 2.3.4.2 For cable width of 6", each support must support up to 82kg (180lbs).
  - 2.3.4.3 For cable width of 8", each support must support up to 104kg (230lbs).
  - 2.3.4.4 For cable width of 12", each support must support up to 136kg (300lbs).

### **2.4 CABLE TRAY SUPPORTS – TRAPEZE SUPPORTS**

- 2.4.1 Must be compatible with cable tray and allow for cable tray to be securely fastened to a wall
- 2.4.2 Must be able to mount on  $\frac{3}{8}$ " threaded rod.
- 2.4.3 Must be able to support between 68kg and 136kg (150 ~ 300 lbs) loads per span, based on width of cable tray:
  - 2.4.3.1 For cable width of 4", each support must support up to 68kg (150lbs).
  - 2.4.3.2 For cable width of 6", each support must support up to 82kg (180lbs).
  - 2.4.3.3 For cable width of 8", each support must support up to 104kg (230lbs).
  - 2.4.3.4 For cable width of 12", each support must support up to 136kg (300lbs).

### **3 PART 3- EXECUTION**

#### **3.1 INSTALLATION**

- 3.1.1 Contractor shall be responsible for the complete supply and installation of the overhead basket type cable tray along with the installation of all supports, dropouts (waterfalls) fittings, connectors threaded rods, bolts, brackets, clips, and miscellaneous hardware for a complete basket cable tray and support system.
  - 3.1.2 Install overhead basket type cable tray as shown on the drawings, sketches and be securely attached under the installation guidelines of the cable tray manufacturer.
  - 3.1.3 The basket cable tray supports can be installed on either side of the tray or supported in the centre of the cable tray.
  - 3.1.4 There shall be no sharp edges on any cable trays, exposed rods, bolts, nuts etc.
  - 3.1.5 Cut back all exposed hanging rods to a maximum of 2" to prevent accidental injury.
  - 3.1.6 Cable tray is to be properly supported at the end of the tray at the wall locations in the TR locations.
  - 3.1.7 Contractor to supply and install properly sized and the correct quantity of dropouts (waterfalls) at the cabinet and or data rack locations for the total number of data cables plus 50% growth.
  - 3.1.8 The basket tray is to be cut to accept the waterfalls within the cable tray. No cabling shall run over the side of or under the cable tray.
  - 3.1.9 Ground cable trays as per Section 27 05 26.
  - 3.1.10 Quality and workmanship shall be the highest of professional tradesman levels to be accepted for completion.
  - 3.1.11 The contractor shall provide installers trained in the installation of the cable tray, regulations and installation standards.
  - 3.1.12 Clearances:
    - 3.1.12.1 Minimum of 6" vertical clearance from the top of the cable trays installed in tiers except where cables of 2" in diameter or greater are installed, then the clearance shall be 12".
    - 3.1.12.2 Minimum of 12" vertical clearance from the top of the cable trays installed to all ceilings, heating ducts, heating equipment and 6" for short length obstructions.
    - 3.1.12.3 Minimum of 10" horizontal clearance from the side of the cable tray mounted adjacent to each other or to walls or obstructions.
    - 3.1.12.4 Clearances for cable trays shall be in accordance with the Canadian Electrical Code C22.1-09.
    - 3.1.12.5 To minimize any possibility of disruption, maintain the following minimum clearances from electrical and heat sources when installing basket tray:
-



**CLEARANCES TABLE**

<b>Item</b>	<b>Minimum Clearance</b>
Motor	1.2 m ( 4'-0" )
Transformers	1.2 m ( 4'-0" )
Conduit and cables used for electrical distribution less than 1kV	0.3 m ( 1'-0" )
Conduit and cables used for electrical distribution greater than 1kV	1.0 m ( 3'-0" )
Fluorescent Light Fixtures	12 cm ( 5" )
Pipes (gas, oil, water, etc)	0.3 m ( 1'-0" )
HVAC (equipment, ducts, etc)	15 cm ( 6 " )

END OF SECTION

---

## **1 PART 1- GENERAL**

### **1.1 WORK INCLUDED**

- 1.1.1 Comply with the General requirements and documents referred to within.
- 1.1.2 Provide labour, materials, products, equipment and services to complete the identification for communications systems work specified within.
- 1.1.3 To be read in conjunction with associated electrical and communication specification sections.
- 1.1.4 The contractor should seek clarification from the UTM I&ITS Designate on site conditions and on any technical, work and/or premises-related questions without delay.

### **1.2 RELATED DOCUMENTS**

- 1.2.1 Drawings and general provisions of the contract, including general and supplementary conditions apply to this section. Refer to the following for additional information.
  - 1.2.2 27 05 13 Communication Services
  - 1.2.3 27 05 26 Grounding and Bonding for Communications Systems
  - 1.2.4 27 05 29 Hangers and Supports for Communication Systems
  - 1.2.5 27 05 33 Conduits and Back Boxes for Communication Systems
  - 1.2.6 27 05 36 Cable Trays for Communication Systems
  - 1.2.7 27 05 55 Testing for Communication Services
  - 1.2.8 27 11 16 Communication Cabinets, Racks, Frames and Enclosures
  - 1.2.9 27 11 19 Communication Termination Blocks and Patch Panels
  - 1.2.10 27 11 23 Communications Cable Management and Ladder Rack
  - 1.2.11 27 11 26 Communications Rack Mounted Power and Power Strips
  - 1.2.12 27 13 13 Communications Copper Backbone Cabling
  - 1.2.13 27 13 13 13 Communications Copper Cable Splicing and Terminations
  - 1.2.14 27 13 23 Communications Optical Fibre Backbone Cabling
  - 1.2.15 27 13 23 13 Communications Optical Fibre Splicing and Terminations
  - 1.2.16 27 15 01 16 Voice Communications Horizontal Cabling
  - 1.2.17 27 15 01 19 Data Communications Horizontal Cabling
  - 1.2.18 27 15 43 Communication Faceplates and Connectors
  - 1.2.19 27 16 19 Communication Patch Cords and Cross Connect Wire
-

### **1.3 QUALITY ASSURANCE**

- 1.3.1 Only new products and applications listed in this section may be used unless otherwise submitted for approval.

### **1.4 SYSTEM DESCRIPTION**

- 1.4.1 The contractor shall furnish all labour, materials, tools and other equipment necessary to provide a complete labelling system for the horizontal and backbone (copper and fibre) cabling system.
- 1.4.2 The contractor shall be responsible for completion of all work included in the contract and shall employ certified, skilled technicians as necessary to satisfy all work and trades.

## **2 PART 2 - PRODUCTS**

- 2.1 All adhesive cable labels shall meet the legibility, defacement, and adhesion requirements specified in UL 969 (Ref. D-16). In addition, the labels shall meet the general exposure requirements in UL 969 for indoor use.
- 2.2 Cable wrap labels shall be self-laminating vinyl construction with a white printing area and a clear tail that self-laminates the printed area when wrapped around a cable. The clear area should be of sufficient length to wrap around the cable at least one and one-half times.

## **PART 3- EXECUTION**

### **3.1 INSTALLATION**

- 3.1.1 All labelling should be unique across the entire intra-building and/or inter-building wiring infrastructure.
- 3.1.2 Labels are to be mechanically printed using a laser/inkjet printer.
- Font size 8 is the preferred size. However, font sizes 7 or 6 should be used if the entire information cannot fit adequately on the first or second lines of the label, as detailed further in this section. The following is an example mockup of a patch panel labelling.



- 3.1.3 Handwritten labels are not permitted.
- 3.1.4 Labels obscured from view will not be acceptable and will be replaced by the contractor at no cost to the client.
- 3.1.5 A machine printed label with the cable label will be affixed, preferably behind a clear, protective, cover.
- 3.1.6 Each label shall be self-adhesive with 10 or 12-point black printing on a white background
- 3.1.7 One label should be attached to the front of the work area outlet faceplate, one to the front of the GigaBix Field face plate, one on the pigtail GigaBIX face plate and one within 10cm (approximately 4 inches) of each end of the pigtail cable. The labelling scheme for the horizontal cabling is as follows:

**<TR Designation>-<Room #>-<punch down location>**

Where:

TR Designation: is a 2 or 3 character identifier for the TR in which the horizontal cable is terminated.

Room #: is the official room number for the Work Area where the horizontal cable is coming from

Punch Down Location: contains 1 letter identifying the patch panel of GigabBIX block in the TR, and 2 digits indicating which position the cable is in. (01-24 or 01-48 in the case of a patch panel, or 01-72 in the case of a GigaBIX block)

Examples:

5R-551-E06: A cable starting in room 551 and terminated in telecom room 5R, patch panel E, jack 6

- 3.1.8 Each pig-tail will be labeled with the punch down location as specified in the previous section
- 3.1.9 Patch panels and GigaBIX blocks shall have labels affixed that correspond with the horizontal cable or pig-tail terminated at that position.



- 3.1.10 Each fibre port on the fibre strip in all fibre patch panels shall be labelled.
- 3.1.11 Each fibre patch panel shall indicate the destination along with fibre count in large font for ease of reading.
- 3.1.12 Example: **12-STRAND SM EV013 to EV453.**
- 3.1.13 Cabling contractor to supply and leave in the TR 25% spare labels for future use.

END OF SECTION

## **1 PART 1- GENERAL**

### **1.1 WORK INCLUDED**

- 1.1.1 Comply with the General requirements and documents referred to within.
- 1.1.2 Provide labour, materials, products, equipment and services to complete the testing for communications systems work specified within.
- 1.1.3 To be read in conjunction with associated electrical and communication specification sections.
- 1.1.4 The contractor should seek clarification from the UTSC I&ITS Designate on site conditions and on any technical, work and/or premises-related questions without delay.

### **1.2 RELATED DOCUMENTS**

- 1.2.1 Drawings and general provisions of the contract, including general and supplementary conditions apply to this section. Refer to the following for additional information.
- 1.2.2 27 05 13 Communication Services
- 1.2.3 27 05 26 Grounding and Bonding for Communications Systems
- 1.2.4 27 05 29 Hangers and Supports for Communication Systems
- 1.2.5 27 05 33 Conduits and Back Boxes for Communication Systems
- 1.2.6 27 05 36 Cable Trays for Communication Systems
- 1.2.7 27 05 53 Identification for Communication Systems
- 1.2.8 27 11 16 Communication Cabinets, Racks, Frames and Enclosures
- 1.2.9 27 11 19 Communication Termination Blocks and Patch Panels
- 1.2.10 27 11 23 Communications Cable Management and Ladder Rack
- 1.2.11 27 11 26 Communications Rack Mounted Power and Power Strips
- 1.2.12 27 13 13 Communications Copper Backbone Cabling
- 1.2.13 27 13 13 13 Communications Copper Cable Splicing and Terminations
- 1.2.14 27 13 23 Communications Optical Fibre Backbone Cabling
- 1.2.15 27 13 23 13 Communications Optical Fibre Splicing and Terminations
- 1.2.16 27 15 01 16 Voice Communications Horizontal Cabling
- 1.2.17 27 15 01 19 Data Communications Horizontal Cabling
- 1.2.18 27 15 43 Communication Faceplates and Connectors
- 1.2.19 27 16 19 Communication Patch Cords and Cross Connect Wire

### 1.3 SYSTEM DESCRIPTION

- 1.3.1 The contractor shall furnish all labour, materials, tools and other equipment necessary to provide manufacturer-certified test results, and minimum 25-year warranty for the voice, data, and backbone (copper and fibre) cabling system.
- 1.3.2 The contractor shall be responsible for the completion of all work included in the contract and shall employ certified, skilled and trained technicians as necessary to satisfy all work and trades.

## 2 PART 2- PRODUCTS

### 2.1 NOT USED

## 3 PART 3- EXECUTION

### 3.1 VOICE AND DATA TESTING

- 3.1.1 Cabling test results for every UTP cable, voice and data, must be provided at least 5 business days before commissioning of any data drop. Such results must be provided as both PDF and native tester files (e.g. FLW file). Full bandwidth, graphical results of all tests must be provided for all cables.
- 3.1.2 All tests will be full certification tests to current industry standards. All test results to be submitted to the manufacturer to produce a full certification report and warranty certificate covering the installed infrastructure for a minimum of 25 years.
- 3.1.3 All terminated horizontal voice and data cable runs shall be tested for defects in installation and to verify cabling system performance under installed conditions according to the requirements found in the ANSI/TIA-568-C series of standards. All pairs in each installed cable shall be verified prior to system acceptance. Any defect in the cabling system installation, including (but not limited to) cables, connectors, and cordage shall be repaired or replaced in order to ensure total usability of all installed runs.
- 3.1.4 The contractor shall field test all four pairs of communications data UTP cable runs. Cable test results for newly installed cables must **surpass** the accepted ANSI/TIA-1152 Level III and ANSI/TIA-568-C.2 standards parameters, in that cables with Marginal Passes are deemed unsatisfactory and must be repaired prior to system acceptance. Work done on existing cables, due to moves or

changes, whose results are Marginal Passes must be brought up to the UTSC I&ITS Designate's attention prior to system acceptance.

3.1.5 Acceptable testers are as follows:

3.1.5.1 Fluke DSX 5000 or equivalent.

3.1.5.2 Fluke DSX 8000 or equivalent.

3.1.6 Upon completion of the testing by the contractor, the contractor will submit the test results for the various work activities to the UTSC I&ITS Designate.

3.1.7 Failure to provide UTP test results will require the contractor to retest all horizontal voice and data cabling related to the project with no cost to the client.

3.1.8 All horizontal link tests are to be performed using one of the approved testers (3.1.5), equipped with the most recent version of its firmware, calibrated within one year of testing date, and in accordance to ANSI/TIA-1152 standard.

## **3.2 FIBRE TESTING**

3.2.1 Cabling test results for every fibre strand end point must be provided at least 5 business days before commissioning of any fibre pair. Such results must be provided as both PDF and native tester files (e.g. FLW file).

3.2.2 All tests will be full certification tests to current industry standards. All test results to be submitted to the manufacturer to produce a full certification report and warranty certificate covering the installed infrastructure for a minimum of 25 years.

3.2.3 All fibre backbone cable runs shall be 100% tested for defects in installation and its performance verified under installed conditions according to the requirements found in the TIA/EIA-568-C series of standards. All strands in each installed cable shall be verified prior to system acceptance. Any defect in the cabling system installation, including (but not limited to) cables, connectors, and cordage shall be repaired or replaced in order to ensure 100% usability of all installed runs.

3.2.4 All testing to be done with the fibre in its final installed position and configuration. NO testing to be done with strands that are not connected to the appropriate final patch panel assemblies.

3.2.5 Acceptable testers are as follows:

- 3.2.5.1 Fluke DSX 5000 or equivalent.
  - 3.2.5.2 Fluke DSX 8000 or equivalent.
  - 3.2.6 All fibre tests are to be performed using one of the approved testers equipped with the most recent version of its firmware and in accordance to ANSI/EIA/TIA-568-C series of standards.
  - 3.2.7 Tester to be calibrated within one year of testing date.
  - 3.2.8 Contractor must have up to date training for one of the approved testers being used to test any type of optical fibre, including all necessary launch cables and connectors.
  - 3.2.9 Testing method shall be Tier 1 and test for the following parameters, at the very least:
    - Link Insertion Loss (attenuation).
    - Continuity.
    - Connector Polarity.
    - Length.
  - 3.2.10 Testing of all fibre strands **MUST** be completed using the 1-jumper method as stated in the EIA/TIA 568-C standard (1-jumper) so that all strands are tested in pairs and not singularly.
  - 3.2.11 Measurement of end-to-end attenuation at 850nm and 1300nm wavelengths for all connectorized fibres in accordance with the loss test procedure defined by EIA/TIA-526-14, Method B: Optical Power Loss measurements of installed fibre cable plant. Attenuation to be measured from both ends of each strand at both wavelengths (bi-directional testing of all strands).
  - 3.2.12 The maximum overall attenuation loss from end to end shall be less than 3dB.
  - 3.2.13 The contractor shall have access to an OTDR for troubleshooting issues during the project.
  - 3.2.14 All installed fibres and connectors must meet or exceed the minimum specifications of the manufacturer. Any fibres or connectors failing to meet these specifications to be promptly replaced or repaired by contractor at no additional cost to the client.
  - 3.2.15 All installed fibres and connectors shall maintain a maximum total optical attenuation of <0.5 dB through any installed strand pair. Any fibres or connectors failing to meet these specifications to be promptly replaced or repaired by contractor at no additional cost to the client.
  - 3.2.16 Failure to provide fibre test results will require the contractor to retest all optical fibre strands related to the project with no cost to the client.
-



- 3.2.17 All defects and deficiencies which originate or become evident during the warranty period to be repaired or replaced without additional expense to the client within 5 business days. All such work must be performed at a time which is acceptable to the client, which may be outside regular working hours.
- 3.2.18 Contractor to provide a letter of certification within 2 weeks of substantial completion. This letter shall include: notification of the installation, verification of performance of the installed system, manufacturers certification number, identification of installation by location and project number and a copy of the warranty certification request form.



- 3.2.19 Failure to provide UTP test results will require the contractor to retest all horizontal voice and data cabling related to the project with no cost to the client.
- 3.2.20 All horizontal permanent link tests are to be performed using one of the approved testers (3.3.5), equipped with the most recent version of its firmware, calibrated within one year of testing date, and in accordance to ANSI/TIA-1152 standard.
- 3.2.21 All installed backbone copper and connectors must meet or exceed the minimum specifications of the manufacturer. Any pairs or connectors failing to meet these specifications to be promptly replaced or repaired by contractor at no additional cost.
- 3.2.22 All testing and repairing must be completed at least two weeks prior to the area move-in date or system cut-over date.
- 3.2.23 All copper backbone test results/reports to be submitted to the UTSC I&ITS Designate for review and comment at least two weeks prior to any move in date.
- 3.2.24 Failure to provide test results upon request will require the Communication Cabling Contractor to retest all copper cabling with no cost to the client.
- 3.2.25 Provide adequate personnel for immediate on-site problem determination and correction during the move in weekend and occupancy by the owner and for a reasonable period of time thereafter.
- 3.2.26 All defects and deficiencies which originate or become evident during the warranty period to be repaired or replaced without additional expense to the client within 24 hours (1 day). All such work must be performed at a time which is acceptable to the client which may be outside regular working hours.
- 3.2.27 Contractor to provide a letter of certification within 2 weeks of substantial completion. This letter shall include: notification of the installation, verification of performance of the installed system, manufacturers certification number, identification of installation by location and project number and a copy of the warranty certification request form.

END OF SECTION

## **1 PART 1- GENERAL**

### **1.1 WORK INCLUDED**

- 1.1.1 Comply with the General requirements and documents referred to within.
- 1.1.2 Provide labour, materials, products, equipment and services to complete the telecommunication rooms (TRs), cabinets, racks, frames and enclosures for communications systems work specified within.
- 1.1.3 To be read in conjunction with associated electrical and communication specification sections.
- 1.1.4 The contractor should seek clarification from the UTSC I&ITS Designate on site conditions and on any technical, work and/or premises-related questions without delay.

### **1.2 RELATED DOCUMENTS**

- 1.2.1 Drawings and general provisions of the contract, including general and supplementary conditions apply to this section. Refer to the following for additional information.
- 1.2.2 27 05 13 Communication Services
- 1.2.3 27 05 26 Grounding and Bonding for Communications Systems
- 1.2.4 27 05 29 Hangers and Supports for Communication Systems
- 1.2.5 27 05 33 Conduits and Back Boxes for Communication Systems
- 1.2.6 27 05 36 Cable Trays for Communication Systems
- 1.2.7 27 05 53 Identification for Communication Systems
- 1.2.8 27 15 55 Testing for Communication Services
- 1.2.9 27 11 19 Communication Termination Blocks and Patch Panels
- 1.2.10 27 11 23 Communications Cable Management and Ladder Rack
- 1.2.11 27 11 26 Communications Rack Mounted Power and Power Strips
- 1.2.12 27 13 13 Communications Copper Backbone Cabling
- 1.2.13 27 13 13 13 Communications Copper Cable Splicing and Terminations
- 1.2.14 27 13 23 Communications Optical Fibre Backbone Cabling
- 1.2.15 27 13 23 13 Communications Optical Fibre Splicing and Terminations
- 1.2.16 27 15 01 16 Voice Communications Horizontal Cabling
- 1.2.17 27 15 01 19 Data Communications Horizontal Cabling
- 1.2.18 27 15 43 Communication Faceplates and Connectors
- 1.2.19 27 16 19 Communication Patch Cords and Cross Connect Wire

### **1.3 QUALITY ASSURANCE**

- 1.3.1 Only new products listed in this section may be used unless otherwise submitted for approval.

### **1.4 SYSTEM DESCRIPTION**

- 1.4.1 The data racks and or cabinets to be supplied and installed as per this document and drawings to house the various cabling and network hardware associated with this project.

### **1.5 SUBMITTALS**

- 1.5.1 Shop drawings for each type of product indicated in the following document, including construction details, material descriptions, dimensions of individual components and profiles and finishes for the data racks and cabinets. Include rated capacities, operating characteristics along with furnished specialties and accessories.

## 2 PART 2- PRODUCTS

### 2.1 FLOORING SYSTEM

- 2.1.1 The floor finishing in TRs should be of Electrostatic Dissipative (ESD) type. Acceptable products are ESD Vinyl Flooring or ESD epoxy resin system complete with electrode earthing points.

The ESD system must withstand heavy foot and rolling load traffic, increase safety and prevent damage to electronic equipment by providing a continuous static dissipative surface throughout the space to earth ground as per ANSI/TIA-607 specifications (current version including all addenda), have low maintenance and be easy to clean.

### 2.2 DATA RACK

- 2.2.1 Always consult with the UTSC I&ITS Designate before procuring materials. Racks added to an existing installation must match model and maker of existing racks. New installations: **Cabinet Anixter Part number: UT-42U8X12-PDU**
- 2.2.2 Cabinet Dimensions: 800Wx1200Dx2000H
- 2.2.3 Minimum Front and Back clearance of 1 m (3 ft) shall be provided for installation of equipment, Front clearance of 1.2 m (4 ft) is preferable to accommodate deeper equipment

### **3 PART 3- EXECUTION**

#### **3.1 INSTALLATION**

- 3.1.1 Installation of the ESD flooring system must follow the manufacturer's instructions and recommendations.
- 3.1.2 Install data racks along with internal components in the MTR or TR location as identified within this document and associated drawings.
- 3.1.3 Utilize proper fasteners for the vertical wire managers, power bars and all accessories as per manufacture's recommendations and in the various documents.
- 3.1.4 Refer to the Grounding and Bonding Section for more information for grounding of data racks and cabinet

## **1 PART 1- GENERAL**

### **1.1 WORK INCLUDED**

- 1.1.1 Comply with the General requirements and documents referred to within.
- 1.1.2 Provide labour, materials, products, equipment and services to complete the communication termination blocks and patch panels for communications systems work specified within.
- 1.1.3 To be read in conjunction with associated electrical and communication specification sections.
- 1.1.4 The contractor should seek clarification from the UTSC I&ITS Designate on site conditions and on any technical, work and/or premises-related questions without delay.

### **1.2 RELATED DOCUMENTS**

- 1.2.1 Drawings and general provisions of the contract, including general and supplementary conditions apply to this section. Refer to the following for additional information.
- 1.2.2 27 05 13 Communication Services
- 1.2.3 27 05 26 Grounding and Bonding for Communications Systems
- 1.2.4 27 05 29 Hangers and Supports for Communication Systems
- 1.2.5 27 05 33 Conduits and Back Boxes for Communication Systems
- 1.2.6 27 05 36 Cable Trays for Communication Systems
- 1.2.7 27 05 53 Identification for Communication Systems
- 1.2.8 27 15 55 Testing for Communication Services
- 1.2.9 27 11 16 Communication Cabinets, Racks, Frames and Enclosures
- 1.2.10 27 11 23 Communications Cable Management and Ladder Rack
- 1.2.11 27 11 26 Communications Rack Mounted Power and Power Strips
- 1.2.12 27 13 13 Communications Copper Backbone Cabling
- 1.2.13 27 13 13 13 Communications Copper Cable Splicing and Terminations
- 1.2.14 27 13 23 Communications Optical Fibre Backbone Cabling
- 1.2.15 27 13 23 13 Communications Optical Fibre Splicing and Terminations
- 1.2.16 27 15 01 16 Voice Communications Horizontal Cabling
- 1.2.17 27 15 01 19 Data Communications Horizontal Cabling
- 1.2.18 27 15 43 Communication Faceplates and Connectors
- 1.2.19 27 16 19 Communication Patch Cords and Cross Connect Wire

### **1.3 QUALITY ASSURANCE**

- 1.3.1 Only new products listed in this section may be used unless otherwise submitted for approval.

### **1.4 SYSTEM DESCRIPTION**

- 1.4.1 The connecting hardware provides the means of transporting signals between the telecommunication outlet/connector and the horizontal cross connect location in the MTR or TR locations.

### **1.5 SUBMITTALS**

- 1.5.1 Shop drawings for each type of product indicated in the following document, including construction details, material descriptions, dimensions of individual components and profiles and finishes for the termination blocks and patch panels. Include rated capacities, operating characteristics along with furnished specialties and accessories.

## **2 PART 2- PRODUCTS**

### **2.1 GIGABIX SYSTEM**

- 2.1.1 Always consult with the UTSC I&ITS Designate before procuring materials.
- 2.1.2 All Copper terminations should be done using Belden GigaBIX blocks

### **2.2 PATCH PANELS**

- 2.2.1 To be used only on a per-case basis. Must be approved by the UTSC I&ITS Designate prior to any work is performed, or equipment is ordered by the contractor.

### **3 PART 3- EXECUTION**

#### **3.1 INSTALLATION**

- 3.1.1 The All Copper terminations should be completed as per Belden GigaBIX manual
- 3.1.2 Always consult with the UTSC I&ITS Designate if unclear on installation

**END OF SECTION**

## **1 PART 1- GENERAL**

### **1.1 WORK INCLUDED**

- 1.1.1 Comply with the General requirements and documents referred to within.
- 1.1.2 Provide labour, materials, products, equipment and services to complete the copper cable splicing and terminations for the communications systems work specified within.
- 1.1.3 To be read in conjunction with associated electrical and communication specification sections.
- 1.1.4 The contractor should seek clarification from the UTSC I&ITS Designate on site conditions and on any technical, work and/or premises-related questions without delay.

### **1.2 RELATED DOCUMENTS**

- 1.2.1 Drawings and general provisions of the contract, including general and supplementary conditions apply to this section. Refer to the following for additional information.
- 1.2.2 27 05 13 Communication Services
- 1.2.3 27 05 26 Grounding and bonding for Communication Systems
- 1.2.4 27 05 29 Hangers and Supports for Communications Systems
- 1.2.5 27 05 33 Conduits and Back Boxes for Communication Systems
- 1.2.6 27 05 36 Cable Trays for Communication Systems
- 1.2.7 27 05 53 Identification for Communication Systems
- 1.2.8 27 05 55 Testing for Communication Services
- 1.2.9 27 11 16 Communication Cabinets, Racks, Frames and Enclosures
- 1.2.10 27 11 19 Communication Termination Blocks and Patch Panels
- 1.2.11 27 11 23 Communications Cable Management and Ladder Rack
- 1.2.12 27 11 26 Communications Rack Mounted Power and Power Strips
- 1.2.13 27 13 13 Communications Copper Backbone Cabling
- 1.2.14 27 13 23 Communications Optical Fibre Backbone Cabling
- 1.2.15 27 13 23 13 Communications Optical Fibre Splicing and Terminations
- 1.2.16 27 15 01 16 Voice Communications Horizontal Cabling
- 1.2.17 27 15 01 19 Data Communications Horizontal Cabling
- 1.2.18 27 15 43 Communication Faceplates and Connectors

1.2.19 27 16 19 Communication Patch Cords and Cross Connect Wire

### **1.3 QUALITY ASSURANCE**

- 1.3.1 All materials, equipment and parts comprising the unit's specified within this document shall be new and unused and of a current manufacture.
- 1.3.2 Only new products and applications listed in this section may be used unless otherwise submitted for approval.

### **1.4 SYSTEM DESCRIPTION**

- 1.4.1 This copper cabling is designed to be a backbone for analog telephone lines only.
- 1.4.2 This copper backbone cabling serves to interconnect the main demarcation point and the distributed analog voice demarcation points throughout the university.
- 1.4.3 Copper backbone cabling and its connecting hardware provides the means of transporting voice signals between the analog voice telecommunication room and the horizontal cross-connect location in the main demarcation room.
- 1.4.4 Splices shall not be installed in the backbone cabling.
- 1.4.5 The backbone design is based on a star topology from each TR location to the designated demarc TR location.

### **1.5 SUBMITTALS**

- 1.5.1 Shop drawings shall be submitted for each type of product indicated or equivalent in the following document.

## **2 PART 2- PRODUCTS**

### **2.1 BIX HARDWARE**

- 2.1.1 The 250 and 300 pair mounts shall be wall mounted or installed in BIX frames.
- 2.1.2 These mounts feature an interlocking design to allow them to be stacked for larger cross-connect installations.
- 2.1.3 Assembled with interlocking distribution rings into easily expandable wall mounted installations.
- 2.1.4 The distribution ring is used for wall mount installations providing a cross-connect channel for jumper wires.
- 2.1.5 The distribution rings interlocks with all BIX type mounts.
- 2.1.6 The BIX distribution connector (1A) is a 25pr connector.
- 2.1.7 Each connector is equipped with 50 double-ended insulation displacement connection (IDC).

## **3 PART 3- EXECUTION**

### **3.1 COPPER BACKBONE INSTALLATION**

- 3.1.1 The copper backbone shall be installed in the appropriate conduits, pathways and routes that have been approved for inter-building and intra-building.
- 3.1.2 One 200pr OSP cable (or equivalent) shall be installed from the campus demarc to the TR location designated as the demarcation location for that building.

### **3.2 GENERAL INSTALLATION INFORMATION**

- 3.2.1 Any cable damaged or exceeding recommended installation parameters during installation shall be replaced by the contractor prior to final acceptance at no cost to the owner of the cabling system.
- 3.2.2 All backbone cables shall be identified by a self-adhesive label in accordance with the System Documentation section of this document, TIA/EIA-606-B, and section 27 05 53
- 3.2.3 The copper backbone shall be installed using the appropriate conduits, pathways and routes that have been approved.
- 3.2.4 Refer to section 27 05 36 for additional information on clearances.

**END OF SECTION**

## **1 PART 1- GENERAL**

### **1.1 WORK INCLUDED**

- 1.1.1 Comply with the General requirements and documents referred to within.
- 1.1.2 Provide labour, materials, products, equipment and services to complete the copper backbone for the communications systems work specified within.
- 1.1.3 To be read in conjunction with associated electrical and communication specification sections.
- 1.1.4 The contractor should seek clarification from the UTSC I&ITS Designate on site conditions and on any technical, work and/or premises-related questions without delay.

### **1.2 RELATED DOCUMENTS**

- 1.2.1 Drawings and general provisions of the contract, including general and supplementary conditions apply to this section. Refer to the following for additional information.
- 1.2.2 27 05 13 Communication Services
- 1.2.3 27 05 26 Grounding and Bonding for Communication Systems
- 1.2.4 27 05 29 Hangers and Supports for Communications Systems
- 1.2.5 27 05 33 Conduits and Back Boxes for Communication Systems
- 1.2.6 27 05 36 Cable Trays for Communication Systems
- 1.2.7 27 05 53 Identification for Communication Systems
- 1.2.8 27 05 55 Testing for Communication Services
- 1.2.9 27 11 16 Communication Cabinets, Racks, Frames and Enclosures
- 1.2.10 27 11 19 Communication Termination Blocks and Patch Panels
- 1.2.11 27 11 23 Communications Cable Management and Ladder Rack
- 1.2.12 27 11 26 Communications Rack Mounted Power and Power Strips
- 1.2.13 27 13 13 13 Communications Copper Cable Splicing and Terminations
- 1.2.14 27 13 23 Communications Optical Fibre Backbone Cabling
- 1.2.15 27 13 23 13 Communications Optical Fibre Splicing and Terminations
- 1.2.16 27 15 01 16 Voice Communications Horizontal Cabling
- 1.2.17 27 15 01 19 Data Communications Horizontal Cabling
- 1.2.18 27 15 43 Communication Faceplates and Connectors
- 1.2.19 27 16 19 Communication Patch Cords and Cross Connect Wire

### **1.3 QUALITY ASSURANCE**

- 1.3.1 All materials, equipment and parts comprising the unit's specified within this document shall be new and unused and of a current manufacture.
- 1.3.2 Only new products and applications listed in this section may be used unless otherwise submitted for approval.

### **1.4 SYSTEM DESCRIPTION**

- 1.4.1 This copper cabling is designed to be a backbone for analog telephone lines only.
- 1.4.2 This copper backbone cabling serves to interconnect the main demarcation point and the distributed analog voice demarcation points throughout the university.
- 1.4.3 Copper backbone cabling and its connecting hardware provides the means of transporting voice signals between the analog voice telecommunication room and the horizontal cross-connect location in the main demarcation room
- 1.4.4 The copper backbone cabling shall contain no more than two transition points between the telecommunication room and the demarcation room.
- 1.4.5 Splices shall not be installed in the backbone cabling.
- 1.4.6 The backbone design is based on a star topology from each TR location to the designated demarc TR location.

### **1.5 SUBMITTALS**

- 1.5.1 Shop drawings shall be submitted for each type of product indicated or equivalent in the following document.

## 2 PART 2- PRODUCTS

### 2.1 COPPER OSP BACKBONE CABLE (INTER-BUILDING)

- 2.1.1 The OSP-rated cable type is a rugged multi-pair cable series that meets and exceeds ANSI/TIA/EIA-568-A for Category 3 transmission characteristics.
- 2.1.2 Conductors 24 AWG solid copper.
- 2.1.3 Cable core-25pr cables all twisted placed in a cable core. 50pr cables and more are formed by binder groups of 25pr.
- 2.1.4 The copper cable is filled with waterproofing compound and wrapped with a non-hygroscopic core tape.

### 2.2 COPPER BACKBONE CABLE (INTRA-BUILDING)

- 2.2.1 The riser-rated cable type is a rugged multi-pair cable series that meets and exceeds ANSI/TIA/EIA-568-A for Category 3 transmission characteristics.
- 2.2.2 Conductors 24 AWG solid copper.
- 2.2.3 Insulation: Inner layer Polyolefin, Outer layer Polyvinyl Chloride.
- 2.2.4 Cable core-25pr cables all twisted placed in a cable core. 50pr cables and more are formed by binder groups of 25pr.
- 2.2.5 PVC jacket is gray.
- 2.2.6 Printed at intervals indicating cable code AWG listings (NRC Code and or CSA), verification, date, time, machine code and length (meters/feet).

## 3 PART 3- EXECUTION

### 3.1 NOT APPLICABLE

END OF SECTION

## **1 PART 1- GENERAL**

### **1.1 WORK INCLUDED**

- 1.1.1 Comply with the General requirements and documents referred to within.
- 1.1.2 Provide labour, materials, products, equipment and services to complete the optical fiber splicing and terminations for the communications systems work specified within.
- 1.1.3 To be read in conjunction with associated electrical and communication specification sections.
- 1.1.4 The contractor should seek clarification from the UTSC I&ITS Designate on site conditions and on any technical, work and/or premises-related questions without delay.

### **1.2 RELATED DOCUMENTS**

- 1.2.1 Drawings and general provisions of the contract, including general and supplementary conditions apply to this section. Refer to the following for additional information.
  - 1.2.2 27 05 13 Communication Services
  - 1.2.3 27 05 26 Grounding and Bonding for Communication Systems
  - 1.2.4 27 05 29 Hangers and Supports for Communications Systems
  - 1.2.5 27 05 33 Conduits and Back Boxes for Communication Systems
  - 1.2.6 27 05 36 Cable Trays for Communication Systems
  - 1.2.7 27 05 53 Identification for Communication Systems
  - 1.2.8 27 05 55 Testing for Communication Services
  - 1.2.9 27 11 16 Communication Cabinets, Racks, Frames and Enclosures
  - 1.2.10 27 11 19 Communication Termination Blocks and Patch Panels
  - 1.2.11 27 11 23 Communications Cable Management and Ladder Rack
  - 1.2.12 27 11 26 Communications Rack Mounted Power and Power Strips
  - 1.2.13 27 13 13 Communications Copper Backbone Cabling
  - 1.2.14 27 13 13 13 Communications Copper Cable Splicing and Terminations
  - 1.2.15 27 13 23 13 Communications Optical Fibre Splicing and Terminations
  - 1.2.16 27 15 01 16 Voice Communications Horizontal Cabling
  - 1.2.17 27 15 01 19 Data Communications Horizontal Cabling
  - 1.2.18 27 15 43 Communication Faceplates and Connectors
  - 1.2.19 27 16 19 Communication Patch Cords and Cross Connect Wire
-

### 1.3 QUALITY ASSURANCE

- 1.3.1 All materials, equipment and parts comprising the unit's specified within this document shall be new and unused and of a current manufacture.
- 1.3.2 Only new products and applications listed in this section may be used unless otherwise submitted for approval.

### 1.4 SYSTEM DESCRIPTION

- 1.4.1 Backbone cabling system connects all campus buildings and TRs together, comprising both inter-building and intra-building cabling. It includes backbone cables, intermediate and main cross-connects, inner duct, patch cords and jumpers used for backbone-to-backbone cross connections.
- 1.4.2 Splices shall not be installed in the backbone cabling.
- 1.4.3 The backbone design is based on a star topology from each TR location to the designated demarc TR location.
- 1.4.4 **Inter-building** backbone cabling shall consist of two paths, as geographically distinct as possible. One (1) cable will be terminated in the closest campus data centre; one (1) cable will be terminated in a TR designated as the Campus Backbone Demarcation. In the case where a campus does not have easy access to the data centre, there will be two (2) geographically diverse Campus Backbone Demarcation locations.
- 1.4.5 The number of OS2 optical fibre strands for **inter-building** communication will be 2 x 24 strands amounting to 48 strands in total.
- 1.4.6 **Intra-building** backbone cabling shall connect all TRs to the MTR in a given building. Only MTP factory terminated ends, OS2 trunks are allowed. The number of OS2 optical fibre strands for **intra-building** communication will be 1 x 24 strands to each TR
- 1.4.7 Podiums requiring fiber uplink must be connected with 1x12 fiber trunk please refer to 27 13 23 subsection 2.1.2

## 1.5 SUBMITTALS

- 1.5.1 Shop drawings shall be submitted for each type of product indicated or equivalent in the following document.
- 1.5.2 Upon completion the contractor must provide the manufacturer 25 Year warranty in name of client within ten (10) business days of project completion.

## 2 PART 2 - PRODUCTS

### 2.1 FIBRE BACKBONE CABLE

- 2.1.1 Each TR will be connected to the building Demarcation Point by one (1) 24-strand single-mode, EDGE(tm) Universal Systems MTP(r) Connector Trunk.

Part Numbers:

- G909024GPNDDUXXXF(Non-armored, must be inside a plenum innerduct)
- G909024GADDDUXXXF(Armored, must be grounded on both sides)

\*xxx = cable length in feet (5 feet increments)

- 2.1.2 Each Classroom containing a Podium will be connected to the building Demarcation Point by one (1) 12-strand single-mode, EDGE(tm) Universal Systems MTP(r) Connector Trunk. The fiber shall be mounted inside the Podium in a Corning low profile module housing.

**Part Numbers:**

- G909012GPNDDUXXXF(Non-armored, must be inside a plenum innerduct)
- G909012GADDDUXXXF(Armored, must be grounded on both sides)

\*xxx = cable length in feet (5 feet increments)

- ECM-UM12-04-89G (Corning Low profile Single mode cassette)
- EDGE-SMH(Low profile module housing)

- 2.1.3 Unless otherwise specified in the tender, inter-building OSP fiber cable will be Corning FREEDM Loose Tube Indoor Outdoor OS2 cable

- 2.1.4 **Inter-building** fibre requires a tracer/locator wire (2.1.5 below) **and** detectable warning tape (2.1.6 below) to be placed with direct burial cable, pipe and microduct installation (air-assisted cable).

- 2.1.5 A tracer/locator wire shall have a solid or stranded copper conductor, as per ASTM B-1, B-3, or B-8 (Standard Specification for Soft Drawn Bare Copper Wire). Insulation shall be yellow in colour and must have high molecular weight polyethylene (HMWPE) ASTM D-1248.
-



- 2.1.6 A detectable warning tape shall be orange in colour and be installed above the cable as set by the A.P.W.A standard. Sizes and dimensions of the tape are determined by the depth the cable is buried:

Warning Tape Width / Recommended Depth:

2" width for up to 12" depth

3" width for up to 18" depth

6" width for up to 24" depth

### **3 PART 3 – EXECUTION**

#### **3.1 UNDERGROUND CONDUITS: INSTALLATION**

- 3.1.1 Fibre optic installations must be recorded in a professional manner including, but not limited to, proper route drawings, fibre strand assignments, loss readings and OTDR traces.
- 3.1.2 Newly installed conduits should be a minimum size of 4", complete with a pull cable.
- 3.1.3 For every 100-metre segment:
- The segment run shall be as straight as possible. If bends are required, the sum of all bend angles may add up to maximum 90 degrees (e.g. 1 x 95° bend, or 2 x 45° bends, 1 x 45° bend + 3 x 15° bends, and so on).
  - A junction box must be installed.
  - Lubricants compatible with the cable jacket must be used.
- 3.1.4 Coordinates of all utilities recorded and provided for future reference, including but not limited to: manholes, handholes, conduits, splice locations, building entrances..etc

**END OF SECTION**

## **1 PART 1- GENERAL**

### **1.1 WORK INCLUDED**

- 1.1.1 Comply with the General requirements and documents referred to within.
- 1.1.2 Provide labour, materials, products, equipment and services to complete the optical fiber splicing and terminations for the communications systems work specified within.
- 1.1.3 To be read in conjunction with associated electrical and communication specification sections.
- 1.1.4 The contractor should seek clarification from the UTSC I&ITS Designate on site conditions and on any technical, work and/or premises-related questions without delay.

### **1.2 RELATED DOCUMENTS**

- 1.2.1 Drawings and general provisions of the contract, including general and supplementary conditions apply to this section. Refer to the following for additional information.
  - 1.2.2 27 05 13 Communication Services
  - 1.2.3 27 05 26 Grounding and Bonding for Communication Systems
  - 1.2.4 27 05 29 Hangers and Supports for Communications Systems
  - 1.2.5 27 05 33 Conduits and Back Boxes for Communication Systems
  - 1.2.6 27 05 36 Cable Trays for Communication Systems
  - 1.2.7 27 05 53 Identification for Communication Systems
  - 1.2.8 27 05 55 Testing for Communication Services
  - 1.2.9 27 11 16 Communication Cabinets, Racks, Frames and Enclosures
  - 1.2.10 27 11 19 Communication Termination Blocks and Patch Panels
  - 1.2.11 27 11 23 Communications Cable Management and Ladder Rack
  - 1.2.12 27 11 26 Communications Rack Mounted Power and Power Strips
  - 1.2.13 27 13 13 Communications Copper Backbone Cabling
  - 1.2.14 27 13 13 13 Communications Copper Cable Splicing and Terminations
  - 1.2.15 27 13 23 13 Communications Optical Fibre Splicing and Terminations
  - 1.2.16 27 15 01 16 Voice Communications Horizontal Cabling
  - 1.2.17 27 15 01 19 Data Communications Horizontal Cabling
  - 1.2.18 27 15 43 Communication Faceplates and Connectors
-

1.2.19 27 16 19 Communication Patch Cords and Cross Connect Wire

### 1.3 QUALITY ASSURANCE

- 1.3.1 All materials, equipment and parts comprising the unit's specified within this document shall be new and unused and of a current manufacture.
- 1.3.2 Only new products and applications listed in this section may be used unless otherwise submitted for approval.

### 1.4 SYSTEM DESCRIPTION

- 1.4.1 Backbone cabling system connects all campus buildings and TRs together, comprising both inter-building and intra-building cabling. It includes backbone cables, intermediate and main cross-connects, inner duct, patch cords and jumpers used for backbone-to-backbone cross connections.
- 1.4.2 The fibre backbone cabling shall contain no more than two transition points between TRs.
- 1.4.3 Splices shall not be installed in the backbone cabling.
- 1.4.4 The backbone design is based on a star topology from each TR location to the designated TR location.
- 1.4.5 Definition for **inter-building** backbone cabling: refer to 27 13 23, section 1.4.
- 1.4.6 Definition for **intra-building** backbone cabling: refer to 27 13 23, section 1.4.
- 1.4.7 Unless otherwise specifier Fusion splicing must be used only for OSP fibre termination.

### 1.5 SUBMITTALS

- 1.5.1 Shop drawings shall be submitted for each type of product indicated or equivalent in the following document.
- 1.5.2 Upon completion the contractor must provide the manufacturer 25 Year warranty in name of client within ten (10) business days of project completion.

## **2 PART 2- PRODUCTS**

### **2.1 FIBRE PATCH PANEL SYSTEMS AND ENCLOSURE**

- 2.1.1 All parts must be by Corning only
- 2.1.2 The fibre optic patch panel may vary from 1U to 4U high and will be black in colour.
- 2.1.3 The unit shall have patch cord routing guides that allow a transition and segregation for fibre optic patch cords to exiting the sides of the fibre patch panel.
- 2.1.4 Corning Shuttered module must be Plug & Play™ Universal Module 24 F, Shuttered LC to MTP®, Single-mode (OS2) Part number: CCH-UM24-04-89G

## **3 PART 3- EXECUTION**

### **3.1 FIBRE BACKBONE INSTALLATION**

- 3.1.1 The backbone fibre installation shall comply with the ANSI/TIA 607 requirements (current version including all addenda)-
- 3.1.2 Installation of inter-building cabling: refer to 27 13 23, section 1.4.
- 3.1.3 Installation of intra-building cabling: refer to 27 13 23, section 1.4.
- 3.1.4 Exposed fibre shall be protected with orange, plenum innerduct.

### **3.2 GENERAL INSTALLATION INFORMATION**

- 3.2.1 Any cable damaged or exceeding recommended installation parameters during installation shall be replaced by the contractor prior to final acceptance at no cost to the owner of the cabling system.
- 3.2.2 All backbone cables shall be identified by a self-adhesive label in accordance with the UTSC labeling scheme.
- 3.2.3 The fibre backbone shall be installed and the appropriate conduits, pathways and routes that have been approved.

**END OF SECTION**

## **1 PART 1- GENERAL**

### **1.1 WORK INCLUDED**

- 1.1.1 Comply with the General requirements and documents referred to within.
- 1.1.2 Provide labor, materials, products, equipment and services to complete the horizontal data cabling for communications systems work specified within.
- 1.1.3 To be read in conjunction with associated electrical and communication specification sections.
- 1.1.4 The contractor should seek clarification from the UTSC I&ITS Designate on site conditions and on any technical, work and/or premises-related questions without delay.

### **1.2 RELATED DOCUMENTS**

- 1.2.1 Drawings and general provisions of the contract, including general and supplementary conditions apply to this section. Refer to the following for additional information.
- 1.2.2 27 05 13 Communication Services
- 1.2.3 27 05 26 Grounding and Bonding for Communications Systems
- 1.2.4 27 05 29 Hangers and Supports for Communications Systems
- 1.2.5 27 05 33 Conduits and Back Boxes for Communication Systems
- 1.2.6 27 05 36 Cable Trays for Communication Systems
- 1.2.7 27 05 53 Identification for Communication Systems
- 1.2.8 27 05 55 Testing for Communication Services
- 1.2.9 27 11 16 Communication Cabinets, Racks, Frames and Enclosures
- 1.2.10 27 11 19 Communication Termination Blocks and Patch Panels
- 1.2.11 27 11 23 Communications Cable Management and Ladder Rack
- 1.2.12 27 11 26 Communications Rack Mounted Power and Power Strips
- 1.2.13 27 13 13 Communications Copper Backbone Cabling
- 1.2.14 27 13 13 13 Communications Copper Cable Splicing and Terminations
- 1.2.15 27 13 23 Communications Optical Fibre Backbone Cabling
- 1.2.16 27 13 23 13 Communications Optical Fibre Splicing and Terminations
- 1.2.17 27 15 43 Communication Faceplates and Connectors
- 1.2.18 27 16 19 Communication Patch Cords and Cross Connect Wire

### **1.3 QUALITY ASSURANCE**

- 1.3.1 All materials, equipment and parts comprising the unit's specified within this document shall be new and unused and of a current manufacture.
- 1.3.2 Only new products and applications listed in this section may be used unless otherwise submitted for approval.
- 1.3.3 All horizontal data cabling must be certified to manufacturer's warranty of at least 25 years.

### **1.4 SYSTEM DESCRIPTION**

- 1.4.1 The horizontal data cabling and its connecting hardware provides the means of transporting signals between the telecommunication outlet/connector and the horizontal cross connect location in the MTR or TR locations.
- 1.4.2 The horizontal data cabling, including BAS, shall be continuous run with no interruptions, cross-connects, signal-boosters, packet regenerators, switches, or hubs (powered or un-powered) of any kind.
- 1.4.3 Every device within the horizontal data cabling shall have an individual home run in a star-topology, no ring, loop, or bus topologies will be accepted. The horizontal data cabling must be home run from the horizontal cross-connect and Work Area Outlet
- 1.4.4 The horizontal data cabling within a designated area shall terminate only in a single Telecommunications Room.
- 1.4.5 The maximum distance for horizontal data cabling Channel is 328 feet

### **1.5 PERFORMANCE REQUIREMENTS**

- 1.5.1 The complete end-to-end horizontal cabling system shall meet or exceed the requirements for Cat 6A cabling as specified by the TIA/EIA-568-C.2 Telecommunication Cabling Standard.

### **1.6 SUBMITTALS**

- 1.6.1 Shop drawings shall be submitted for each type of product indicated or equivalent in the following document.

## 2 PART 2- PRODUCTS

### 2.1 BALANCED TWISTED-PAIR CABLES

- 2.1.1 Data cabling shall be 4-pair balanced twisted pair Cat 6A UTP, plenum rated (CMP) cables for all cabling projects.
- 2.1.2 All horizontal channels shall contain only Belden 10GX Category 6A components, including cables, jacks, patch cords, patch panels, cross-connects, and workstation outlets. In all circumstances the cable shall be Plenum Rated (CMP – part number 10GXW13). Riser Rated cable (CMR) is not to be used.
- 2.1.3 The horizontal Cat 6 data cable jackets shall be **white** in colour
- 2.1.4 The cable conductors shall be 23 AWG solid copper.
- 2.1.5 The minimum bend radius shall be no greater than four times the OD of the cable.

### 2.2 GIGABIX

- 2.2.1 All new network and telephone cables will be terminated in Belden/IBDN GigaBIX 72 port mounts (AX101472) inside the Telecommunications Closets (TR). The GigaBIX will be in a “Cross-Connect” layout. The cables will be cross-connected, and pig-tails will be installed, and labeled, into the cable management of the network equipment cabinets. If analogue phone lines are to be used, the regular BIX block will be installed on the wall as near to the GigaBIX as possible to facilitate cross-connections.
- 2.2.2 All GigaBIX installations will have cable management modules (AX101469) installed to provide a false wall for easier cable management and routing of cables. In between all GigaBIX panels a GigaBIX management ring (AX10178) will be installed to manage the cross connect wires this ring should be sufficient to manage 450 cross connect wires. GigaBIX retainer (AX101486) will be installed to protect connections from slipping out. Termination bars (AX101719) will be installed on all cables to prevent misalignment and unneeded pair untwisting.

## 3 PART 3- EXECUTION

### 3.1 DATA CABLE INSTALLATION

- 3.1.1 The contractor shall clarify with the UTSC I&ITS Designate the ANSI/TIA termination standard that must be employed, prior to commencing the work
  - 3.1.2 No data cable Channel shall exceed 328ft. Any Channel longer than 328ft shall be reported immediately to the UTSC I&ITS Designate.
  - 3.1.3 Pair untwist at the termination point shall not exceed 13mm (0.5”).
  - 3.1.4 Bend radius of the cable along its pathway and at the termination areas shall not be less than four times the OD of the cable.
  - 3.1.5 The pulling tension on any 4-pair balanced UTP cable shall not exceed 110N (25lbf).
-

- 
- 3.1.6 All cable ties shall be black, touch-fasteners (a.k.a. velcro fasteners) style.
  - 3.1.7 No plastic cable ties are allowed. If found on site during any phase of the project the plastic cable ties will be removed by the contractor at the contractor's expense.
  - 3.1.8 All exposed cables in TRs are to be placed in a neat and professional manner and routed in accordance with the specifications and drawings provided.
  - 3.1.9 If installing horizontal data cabling outlets/connectors through floors/walls and into furniture access locations, all exposed cabling at the workstation between the wall/floor and the furniture access locations is to be wrapped with black split loom tubing, size and length as required to suit.
  - 3.1.10 Cable raceways shall not be filled greater than the TIA/EIA-569-B recommended maximum fill for the particular raceway type, or 40% whichever is less.
  - 3.1.11 Cable support systems shall be provided and installed by contractor everywhere along the cable pathway and shall adhere to the following:
    - 3.1.11.1 Existing cable tray and adjustable cable support as defined in sections 27 05 29 and 27 05 36 shall be used where available.
    - 3.1.11.2 All cable support systems shall be self-supporting.
    - 3.1.11.3 At no point shall cable(s) rest on acoustic ceiling grids, water pipes, metal conduits, ceiling panels or any other structure not defined as a cable support.
    - 3.1.11.4 Horizontal data cabling shall be supported by use of cable trays where clearances allow for the installation of cable trays. See section 27 05 36 for details on cable tray systems and minimum required clearances.
    - 3.1.11.5 Where clearances do not allow for the installation of cable trays, contractor shall submit a request to the UTSC I&ITS Designate for additional instructions. UTSC I&ITS may, at its own discretion, lower the minimum required clearances to allow for the installation of cable tray, or instruct contractor to use alternate cable supports as defined in sections 27 05 29 and 27 05 33.
    - 3.1.11.6 No excessive slack or service loop shall be left behind. All service loops shall be kept under 10 feet.
  - 3.1.12 Horizontal data cables shall be bundled in groups of no more than 16 cables. Cable bundle quantities in excess of 16 cables may cause deformation of the bottom cables within the bundle, which will degrade the performance of those cables.
  - 3.1.13 The horizontal data cable shall be installed above fire-sprinkler systems and shall not be attached to such systems or any associated ancillary equipment or hardware. The cabling system and its associated pathways shall be installed so that they do not obscure any valves, fire alarm conduit(s), boxes, or other control devices.
  - 3.1.14 Any data cable damaged or exceeding recommended installation parameters during installation shall be replaced by the contractor prior to final acceptance at no cost to the owner of the cabling system.
  - 3.1.15 All data cables shall be identified by a self-adhesive label in accordance with the
-

Identification for Comm. System section of this specification, Section 27 05 53.

3.1.16 Colored jacks will be used to differentiate cable types.

3.1.17 The color scheme for 8P8C modular connector jacks is the following:

Part Number	Description	
AX101070	GigaFlex PS6+ module, KEYCONNECT T568A/B, Green	Jack & Icon colors for Cat 6 drops
AX101063	GigaFlex PS6+ module, KEYCONNECT T568A/B, Gray	Jack & Icon colors for Voice drops
AX101067	GigaFlex PS6+ module, KEYCONNECT T568A/B, Orange	Jack & Icon colors for Security drops

3.1.18 To minimize any possibility of disruption, maintain the following minimum clearances from electrical and heat sources when routing cables:

<b>CLEARANCES TABLE</b>	
<b>Item</b>	<b>Minimum Clearance</b>
Motor	1.2 m ( 4'-0" )
Transformers	1.2 m ( 4'-0" )
Conduit and cables used for electrical distribution less than 1kV	0.3 m ( 1'-0" )
Conduit and cables used for electrical distribution greater than 1kV	1.0 m ( 3'-0" )
Fluorescent Light Fixtures	12 cm ( 5" )
Pipes (gas, oil, water, etc)	0.3 m ( 1'-0" )
HVAC (equipment, ducts, etc)	15 cm ( 6 " )

**END OF SECTION**

## **1 PART 1- GENERAL**

### **1.1 WORK INCLUDED**

- 1.1.1 Comply with the General requirements and documents referred to within.
- 1.1.2 Provide labour, materials, products, equipment and services to complete the faceplates and connectors for the communications systems work specified within.
- 1.1.3 To be read in conjunction with associated electrical and communication specification sections.
- 1.1.4 The contractor should seek clarification from the UTSC I&ITS Designate on site conditions and on any technical, work and/or premises-related questions without delay.

### **1.2 RELATED DOCUMENTS**

- 1.2.1 Drawings and general provisions of the contract, including general and supplementary conditions apply to this section. Refer to the following for additional information.
- 1.2.2 27 05 13 Communication Services
- 1.2.3 27 05 26 Grounding and Bonding for Communication Systems
- 1.2.4 27 05 29 Hangers and Supports for Communications Systems
- 1.2.5 27 05 33 Conduits and Back Boxes for Communication Systems
- 1.2.6 27 05 36 Cable Trays for Communication Systems
- 1.2.7 27 05 53 Identification for Communication Systems
- 1.2.8 27 05 55 Testing for Communication Services
- 1.2.9 27 11 16 Communication Cabinets, Racks, Frames and Enclosures
- 1.2.10 27 11 19 Communication Termination Blocks and Patch Panels
- 1.2.11 27 11 23 Communications Cable Management and Ladder Rack
- 1.2.12 27 11 26 Communications Rack Mounted Power and Power Strips
- 1.2.13 27 13 13 Communications Copper Backbone Cabling
- 1.2.14 27 13 13 13 Communications Copper Cable Splicing and Terminations
- 1.2.15 27 13 23 Communications Optical Fibre Backbone Cabling
- 1.2.16 27 13 23 13 Communications Optical Fibre Splicing and Terminations
- 1.2.17 27 15 01 19 Data Communications Horizontal Cabling
- 1.2.18 27 16 19 Communication Patch Cords and Cross Connect Wire

### **1.3 QUALITY ASSURANCE**

- 1.3.1 All materials, equipment and parts comprising the unit's specified within this document shall be new and unused and of a current manufacture.
- 1.3.2 Only new products and applications listed in this section may be used unless otherwise submitted for approval.

### **1.4 SYSTEM DESCRIPTION**

- 1.4.1 The horizontal voice and data connectors provide the means of transporting signals between the telecommunication outlet/connector and the horizontal cross connect location in the MTR or TR locations.

### **1.5 PERFORMANCE REQUIREMENTS**

- 1.5.1 The voice and data connecting hardware shall match the horizontal voice and data cabling specifications for performance.

### **1.6 SUBMITTALS**

- 1.6.1 Shop drawings shall be submitted for each type of product indicated or equivalent in the following document.

## **2 PART 2- PRODUCTS**

### **2.1 FACEPLATES**

- 2.1.1 Available in 2, 4 and 6 port configurations for greater workstation outer density.
- 2.1.2 Additional accommodations for specific locations as noted in the plans for optical fiber and/or additional copper cables as necessary.
- 2.1.3 Faceplates are compatible for Cat 6 8P8C modular connector
- 2.1.4 Space to facilitate outlet labelling identification and ease of network management.

- 2.1.5 Blanks supplied to fill all unused ports.

### **3 PART 3- EXECUTION**

#### **3.1 DATA CONNECTOR TERMINATION**

- 3.1.1 At the workstation faceplate terminate each data cable on a Green 8P8C modular connector MDVO jack wired TIA/EIA-568A standard.
- 3.1.2 The data 8P8C modular connector jack will be green in colour and shall occupy the top left position of the 4-port faceplate (top to bottom).
- 3.1.3 Use blanks for all unused ports. Blanks to match faceplate colour(White)
- 3.1.4 Include all necessary furniture adaptors/spacers/surface boxes and any other hardware required to ensure the faceplate can be properly installed/secured to the furniture while maintaining a proper bend radius.
- 3.1.5 Include all necessary adaptors/spacers/surface boxes and any other hardware required to ensure the faceplate can be properly installed in the floor box while maintaining a proper bend radius.
- 3.1.6 Any data cable damaged or exceeding recommended installation parameters during termination shall be replaced by the contractor prior to final acceptance at no cost to the owner of the cabling system.
- 3.1.7 All data cables shall be identified by a self-adhesive label in accordance with the Identification for Comm. System section of this specification, 27 05 53.
- 3.1.8 Each data cable shall be clearly labeled on the cable jacket within 4 inches of the termination behind the connector at the faceplate. Labels are to be a self-laminating wrap around style. Labels obscured from view will not be accepted and will be replaced by the contractor at no cost to the client.
- 3.1.9 The data cabling will be terminated on either existing GigaBIX or on new GigaBIX panels.
- 3.1.10 If existing GigaBIX panels are full, the contractor is to install new, GigaBIX hardware including anything required for a complete system
- 3.1.11 Complete the cross-connect at the GigaBIX termination points between field and pigtail side
- 3.1.12 Pair untwist at the termination point shall not exceed 13mm (0.5in).
- 3.1.13 All cable ties shall be black, touch-fasteners (a.k.a. velcro fasteners) style.

END OF SECTION

## **1 PART 1- GENERAL**

### **1.1 WORK INCLUDED**

- 1.1.1 Comply with the General requirements and documents referred to within.
- 1.1.2 Provide labour, materials, products, equipment and services to complete the patch cords, station cords and cross-connect wire for communications systems work specified within.
- 1.1.3 To be read in conjunction with associated electrical and communication specification sections.
- 1.1.4 The contractor should seek clarification from the UTSC I&ITS Designate on site conditions and on any technical, work and/or premises-related questions without delay.

### **1.2 RELATED DOCUMENTS**

- 1.2.1 Drawings and general provisions of the contract, including general and supplementary conditions apply to this section. Refer to the following for additional information.
- 1.2.2 27 05 13 Communication Services
- 1.2.3 27 05 26 Grounding and Bonding for Communication Systems
- 1.2.4 27 05 29 Hangers and Supports for Communications Systems
- 1.2.5 27 05 33 Conduits and Back Boxes for Communication Systems
- 1.2.6 27 05 36 Cable Trays for Communication Systems
- 1.2.7 27 05 53 Identification for Communication Systems
- 1.2.8 27 05 55 Testing for Communication Services
- 1.2.9 27 11 16 Communication Cabinets, Racks, Frames and Enclosures
- 1.2.10 27 11 19 Communication Termination Blocks and Patch Panels
- 1.2.11 27 11 23 Communications Cable Management and Ladder Rack
- 1.2.12 27 11 26 Communications Rack Mounted Power and Power Strips
- 1.2.13 27 13 13 Communications Copper Backbone Cabling
- 1.2.14 27 13 13 13 Communications Copper Cable Splicing and Terminations
- 1.2.15 27 13 23 Communications Optical Fibre Backbone Cabling
- 1.2.16 27 13 23 13 Communications Optical Fibre Splicing and Terminations
- 1.2.17 27 15 01 19 Data Communications Horizontal Cabling
- 1.2.18 27 15 43 Communication Faceplates and Connectors

### **1.3 QUALITY ASSURANCE**

- 1.3.1 Only new products and applications listed in this section may be used unless otherwise submitted for approval.

### **1.4 SYSTEM DESCRIPTION**

- 1.4.1 The data UTP and fibre patch cords provide the means of transporting signals between the telecommunication outlet/connector and the horizontal cross-connect location in the MTR or TR locations.

### **1.5 PERFORMANCE REQUIREMENTS**

- 1.5.1 The fibre patch cords shall match the single-mode backbone fibre.

### **1.6 SUBMITTALS**

- 1.6.1 Shop drawings shall be submitted for each type of product indicated or equivalent in the following document to be approved prior to installation.

## **2 PART 2 - PRODUCTS**

### **2.1 UTP PATCH CORDS**

- 2.1.1 All data patch cords shall conform to the requirements of the ANSI/TIA 568-D series or the latest edition of the Commercial Building Telecommunication cabling Standard for horizontal cabling section.
- 2.1.2 The UTP patch cables will be Belden 10GX Modular cords.
- 2.1.3 The nominal cable diameter of the cordage shall be no greater than 4.72 mm (0.186 in). The minimum bend radius shall be no greater than four times the nominal cable diameter of the cordage.
- 2.1.4 The contractor will consult the tender document and UTSC I&ITS Designate for exact numbers, lengths, and colors.

### **2.2 OPTICAL FIBRE PATCH CORDS (OS2 SINGLE-MODE)**

- 2.2.1 Supply and install Corning OS2 Reverse polarity LC-LC uniboot jumper
- 2.2.2 Patch cords are to be factory assembled and not site prepared.
- 2.2.3 Patch cords shall be the shortest length possible that can be correctly installed. Clarify with the UTSC I&ITS Designate for correct lengths

## **3 PART 3 - EXECUTION**

### **3.1 INSTALLATION**

- 3.1.1 Pigtail patching to the switch port to be done only by UTSC I&ITS Designate.
- 3.1.2 Supply a Cat 6A UTP patch cord for the workstation, and connect it to the data jack on the faceplate. One per data drop installed.

**END OF SECTION**



# **UTSC WIRELESS SPECIFICATION**

## **SITE DESIGN CRITERIA RF DESIGN REQUIREMENTS**

*Valid starting April 21, 2017*

*VERSION 1.0 New Residence*

*Network Administrators*

*Glenn Attwood*

*Manager, Networking and Telecommunications*

[attwood@utsc.utoronto.ca](mailto:attwood@utsc.utoronto.ca)

416-287-7364

*Stan Agafonov*

*Network Administrator*

[sagafonov@utsc.utoronto.ca](mailto:sagafonov@utsc.utoronto.ca)

416-208-8165

*John Stewart*

*Network Administrator*

[jkstewart@utsc.utoronto.ca](mailto:jkstewart@utsc.utoronto.ca)

416-208-4768

## RF requirement guidelines for new APs

1. AP antenna installations must be in line of sight of the intended clients. IITS will not accept AP installations that:

- Do not cover the intended area
- That are hidden from view (external antennas or disabling LEDs are acceptable)
- Mounted on or within 2 feet of a metal object (duct-work, cabinets, etc)
- Located closer than 10 feet to another AP in freespace

All physical installations will be accompanied by our Wireless Network Administrator.

At any time it is noted that a physical change will be required then IITS will immediately disable the affected AP(s). AP to be re-enabled only after an authorized party has relocated the AP and the Wireless Network Administrator has verified the new location is acceptable.

2. 5Ghz 802.11ac first deployment with an optimal cell edge of -65 dBm or better as measured by the client devices expected.

Measurements must be from expected client devices and NOT specialized adapters such as Ekahau NIC300. As there is a large variation between device capabilities a minimum of 3 different device data points required (ex. iPhone, Dell Laptop, Samsung Note).

3. IITS requires the below to create a Wi-Fi capacity report and determine the number of APs required:

- Client device type(s)
- Expected peak #s of associated clients
- Number of SSIDs (including 3rd party networks heard during local survey)
- Expected client data traffic category (email, web browsing, video, etc).

This process is dependent on the information highlighted above as well as the original location survey. These 2 steps (location survey and AP capacity report) must be completed and documented at the start of the project or task without exception. Project manager (or Wireless Admin for smaller installs) will notate and save the original survey, pictures, and capacity plan for future reference.

4. Clients to be load-balanced across radios in any area with a client density of >50.

5. Average channel utilization should be <40%.

If average channel utilization exceeds 60% immediate adjustments to channel plan, power levels, or # of available radios are likely required. This information can be validated from the AP radio interfaces remotely but if possible a site visit is preferred to also obtain the noise-floor measurements using Metageek WiSpy analyzer.

6. Maintain a minimum Signal to Noise (SNR) of 25 for 2.4Ghz clients and 29 for 5Ghz clients.

A detailed explanation of SNR and expected MCS (modulation coding scheme) data rates can be found below for interested readers.

Ex: (-65 db RSSI) - (-93 db Noise Floor) = 28 SNR. Please note that the Noise Floor level required will be based on the original location survey notes and if it's likely that the environment has changed a follow-up check should be arranged to ensure accuracy.

7. Areas with a Noise Floor >-85 db should be investigated and re-mediated whenever possible.

High noise floor significantly impacts the health and performance of associated devices (on our and other Wi-Fi networks). Sources of noise aren't limited to other Wi-Fi transmitters can also be microwave ovens (2.4ghz), electromagnetic equipment (labs), drones, faulty radios, etc. If a high noise floor is observed during a location survey or new AP install a channel modification will be made. If this work-around isn't available the APs will remain off until the source of the problem is isolated and re-mediated.

8. 802.11 retransmissions should be <15%. Automatic health checks should alert to high retransmission rates. Antenna / physical AP health and the physical environment are common causes of high retransmission rates (broken antennas or suboptimal AP mounting etc).

9. Wi-Fi health network verification to be performed on installation, during periodic reviews, and on any new complaints with the following criteria:

- Packet loss <1% and jitter (variance in latency) <100ms

This will be measured using Ekahau on an active survey during normal hours of operation. Any changes required will be logged in a project or ticket (depending on scope) and dealt with on a priority basis by the IITS networking team as directed by the Wireless Network Administrator.

#### UTSC Coverage Requirements

IITS Networking builds a 5 GHZ only coverage design when producing initial designs for future buildings or refresh of existing infrastructure.

Exceptions to the 5 GHZ only coverage design will be necessary in some physical environments (outside, heavy concrete with no available cable trays, etc). However, exceptions will only be agreed by networking if alternative approaches (such as changing antenna types) have been assessed and ruled out for reasons other than additional cost. In other words networking will always recommend a 5 GHZ solution over a 2.4 GHZ if the requirement can be filled with a reasonable change to equipment or cable pathways.

Gathering Spaces (Classrooms, Meeting Rooms, Lounges, lobbies with seating, etc.) with seating for >15 people should have at least one AP inside the space. A possible exception would be in buildings with many adjacent classrooms separated by drywall.

APs outside gathering spaces should be located so they only cover the gathering space. Areas outside classrooms where students gather should be covered by separate APs from the classrooms. It is appropriate for a classroom AP to also cover light foot traffic.

Gathering spaces with seating for less than 15 people should have an AP located no more than one drywall wall away. For high-loss walls (Block, Concrete, Brick, etc.) the AP must be located inside the gathering space.

Capacity for gyms and large auditoriums must be designed for capacity and careful attention to device type and traffic load must be taken. Ekahau Site Survey can plan for capacity but information from those hosting reoccurring events will be required.

APs should not be located in corridors. This is critical in long corridors or when corridors are stacked on different floors. An exception can be considered when the purpose of the AP is to cover the corridor.

APs should not be obstructed with furniture, ceiling tiles, metal duct work, or any other object that causes a db loss from area the clients are located.

Avoid placing APs in the same locations on each floor of a multi-story building (aka, stacking). This is less important in 2-story buildings, and buildings where the path loss two floors from an AP is 50dBm or greater. In all cases APs should only be stacked when there is a compelling reason to do so.

APs must be located at least 10 feet apart in free space, and 25 feet is preferred.

Rooms >300 occupants require creative AP placement to minimize co-channel interference. This is critical when multiple such venues are adjacent to each other in the same building. When the signal from more than 9 APs will be detected ( $RSSI \geq -83\text{dBm}$ ) in a space, APs should be installed with narrow-beam directional antennas pointing downward towards the client devices. Take note that the APs should be no greater than 25 feet from clients but antennas should be 15-20 feet apart in free-space. Creativity in shadowing signal using the physical environment (pillars, stairwells, etc) can provide exceptions to increase AP count without increasing ACI and CCI (adjacent and co-channel interference)

No more than (3) 2.4Ghz radios to be enabled in a space.

The lowest possible power level to service the area must be deployed on both 2.4 and 5Ghz radios.

## Dynamic Frequency Selection (DFS) channels

DFS is a technology process that protects the channels by removing Wi-Fi devices in the event of required use by weather or military radar. When an AP detects DFS transmissions it must move off the channel so as to not interfere with the radar transmission. The use of DFS channels is only recommended in high density indoor deployments. For the purposes of this document high density areas include any space with expected associations greater than 50 per AP (or channel).

DFS channels have a variety of caveats including:

1. DFS client adoption rate is still low (as of April 2017)

2. Client devices don't typically send probe requests on DFS channels so deploying them in a standard channel plan could cause coverage loss or drops. The probing on DFS channels varies by client device and OS considerably but all will favour non-DFS channels while mobile. DFS channels should be deployed in areas considered static (labs versus hallways)
  
3. In the event of an AP detecting radar on the DFS channel the back-down and channel change is disruptive to the client and false triggers are a possibility that we cannot avoid.

### Dual 5 GHZ APs

Channel plan to use non DFS and DFS channels with the DFS channel being on the inner cell (assuming one radio uses 7 DBi antenna and the other 3 DBi). Use 802.11v or other load balancing to hand-off the client to the DFS channel when they are in range of the inner cell (3 DBi antenna radio).

U-NII-1 and U-NII-2 Channels Plan      U-NII-3 and U-NII-2 Channel Plan

36/100 149/116

40/104 153/132

44/108 157/136

48/112 161/140

DFS fallback channel for this setup can be 165 assuming an indoor auditorium deployment not near any wireless P2P bridges.

### Channel Planning

2.4 Ghz Channel      5 Ghz Channel(s)

1      36/40

6      44/48

11      149/153

2,3,4,5,7,8,10,11+ \* UNUSABLE U-NII-2 channels except 120, 124, and 128

Channels 1,6 and 11 will only be used on 2.4 GHZ and channel 157+ reserved for outdoor APs and bridges.

2.4 Ghz radios not required to provide -65 db coverage disabled or moved to a Rogue or Spectrum scanning state.

If significant peer to peer Wi-Fi communication is required (University or approved 3rd party vendor supplied) channels 149 and 153 can be made available.

As there are a limited number of available 2.4 GHZ channels 3rd party vendors will need to coordinate with networking an appropriate channel for their venue/location and operate at the lowest possible power level that provides them SNR of 25 without causing unnecessary interference with existing wifi networks.

## Channel Widths

20mhz only channels are mandatory on UofT operated and authorized Wi-Fi networks. Networks found operating with 40mhz bonded on 2.4 GHZ channels will be removed as they are not for use in shared environment.

20mhz channels are, by default, used for 5 GHZ channels to allow efficient re-use of channels. Also, the larger the channel width the higher the minimum noise floor becomes so for instance a device connecting to 20mhz channel 48 might need to have a noise floor of -97 or better whereas 40mhz channel 46 might required -94. This 3 db difference might seem inconsequential but remember that's double! See Appendix A for more details if desired.

## Data Rates and SNR

See attached MCS spreadsheet that maps 802.11 standard, channel width, and SNR to MCS rate. The higher the MCS rate the more throughput and the higher the throughput the less time the device requires on the air which improves performance for all devices sharing the same channel as well as improves battery life and user experience.

802.11b data rates have been disabled on UofT operated networks (1, 2, 5.5, and 11mbps). It is required that authorized APs must also disable b data rates as these non-ofdm rates dramatically reduce airtime and aren't required on any current devices. Exceptions will be not permitted.

Base data rates are responsible for beacons and other control traffic and the rate that multicast traffic is transmitted.

Base data rates for AN/AC (5 GHZ) set to 12 mbps with 24 mbps supported. Beacons are sent at 12 mbps and acks can be sent at 24 mbps

Base data rates for BGN (2.4 GHZ) set more conservatively at 9mbps and 12 mbps

## **2.4 GHZ Power Levels (Indoors/Outdoors)**

The default is rarely an appropriate power level in our 5 GHZ based deployments and Meru's default of 24 is particularly high.

Acceptable power settings are divisible by 3 and levels higher than 18 should be avoided:

27 (outdoor only), 24, 21, 18, 15, 12, 9, 6, 3, 0

The UTSC approach is to match the power level to that of the capability of the weakest client in the area of coverage. This range is typically 12 - 18 and can be found here <http://clients.mikealbano.com/>.

For high density environments start with the lowest power and increment in 3 db until the RSSI and SNR levels are met for the area and the cell edge is @ -65 or better. Unnecessarily "boosting" the power will interfere with nearby access points and cause sticky client issues so work "up" to get the best results.

## **Unauthorized APs (Rogue APs)**

IITS Networking reserves the right to disconnect, without warning, devices reported or observed to be advertising a University of Toronto Wi-Fi connection

Ad-hoc Wi-Fi as seen on common consumer devices such as printers, tvs, etc should be turned off unless approved by the networking team. Networking will request ad-hoc networks to be disabled if it's suspected to be causing connectivity issues with any UofT Wi-Fi services.

Authorized APs must adhere to channel and power plan guidelines outlined by the networking team and this document. Networking reserves the right to change power and channels to account for RF conditions or environment changes and will note exceptions in their documentation.

## AP Naming Convention

The APs are named: utsc-buildingcoderoomnumber

Ex. utsc-ev303k would be 3rd floor ESCB in the hallway.

The naming convention is important as our business analytics use the radius accounting logs (specifically the AP name reported) to correlate # of users to location.

## Wireless Bridges

Unlicensed wireless bridges should utilize 5Ghz spectrum (channels 149+) and an appropriate channel and power plan to be determined on installation and alignment. DFS channels are to be avoided (if an unlicensed spectrum P2P bridge) and a utility like RadioMobile is useful to assess the appropriate mounting height and tilt of the antennas to guarantee a line of sight connection with no fresnel zone obstructions. It is essential that an appropriate lightning arrester be installed along with water proofing all external connection points and entry points to internal structures and enclosures.

## Appendix A // RF Math

To understand the impact of the RF designs outlined in this document it's important to go over the basic math involved.

Power is measured in milliwatts but often discussed in db. The conversion makes it much easier to compare values quickly.

Rules of 3s and 10s:

For every 3dB of gain, double the absolute power (mW)

For every 3dB of loss, half the absolute power (mW)

For every 10dB of gain, multiplie the absolute power by 10 (mW)

For every 10dB of loss, divide the absolute power by 10 (mW)

A calculator such as <http://rfcalculator.mobi/convert-eirp-dbm.html> can be used to easily calculate the power output of an AP radio (dBm to mW) and can be used to show the 3 dB difference.

The same log math applies for RSSI measurements.

Example: RSSI of -65 is 3 db better than an RSSI of -68. -65 measurement indicates the device received DOUBLE the amount of power (milliwatts).

It might be helpful to highlight that closer the number to 0 the stronger the signal. 0 dBm = 1mw of power

RSSI Scale

0 to -30 = Too loud

-40 to -50 = Great

-50 to -65 = Good

-70 to -75 = Average

-75 to -80 = Poor

Most devices will roam if there is a 10db difference on another received beacon - aka announcement - once they hit the -75 threshold.

-80 - 90 = Very poor

-90 - 100 = Noise floor aka the device cannot distinguish the signal from the other rf energy

Despite this handy chart RSSI is only valid when compared to the Noise Floor and the SNR calculated.

The greater the SNR the greater the modulation rate and higher throughput / less airtime used.

Noise Floor:

Maxwell & Boltzmann: -174 dBm noise per Hz of bandwidth.

20 MHz is +73 dB to 1 Hz (x10 7 times, x2 once)

20 Mhz channel noise is at least -101 dBm

Add system EMF noise, typically 5 dB so the noise floor is about -96 dBm



# UNIVERSITY OF TORONTO

---

## SCARBOROUGH

### **UTSC CLASSROOM TECHNOLOGY / AUDIO-VISUAL SPECIFICATIONS GUIDE**

- 1. Scope of Document***
- 2. The Four Standards***
- 3. Installation Requirements***
- 4. Product Compatibility Requirements***
- 5. Control Programming Standards***

**Blake Markle, CTS-D/I, PMP**

**Classroom Technology and Support Coordinator  
UTSC**

February 2021

Version 2.8

# 1.0 Scope of Document

The purpose of this document is to outline requirements for new classroom technology or audio-visual equipment installations at UTSC.

Described herein are the typical room standards that are currently in place, the manner in which IITS requires the installation to be carried out, preferred products, and finally the programming and interface designs.

## 2.0 The Four Standards

There are four distinct audio-visual standards currently in use at UTSC campus defined by the size and purpose of rooms. Auditoriums and larger classrooms, defined as having 80 seats or more, typically follow the Large Classroom Standard. Smaller classrooms seating ninety-nine or less typically follow the Small Classroom Standard (unless specific requirements dictate the richer features of the Large Classroom Standard). For large boardroom spaces with one central table and 20 or more surrounding seats the UTSC Large Meeting Room Standard is used, and those under 20 seats adhere to the Small Meeting Room Standard.

### 2.1 Large Classroom Standard

The newest version of the large classroom standard has space outfitted with two ceiling-mounted digital projectors, electric projection screen(s), ceiling-mounted speakers, and a wooden podium known as the Full Teaching Station – hereafter FTS.



**Fig 2.1.1: Full Teaching Station angled top view. Note the PC installed on its side on front shelf area giving user access to the USB slots and DVD drive.**



**Fig 2.1.2: Full Teaching Station front view**

The FTS podium itself is a custom millwork wooden lectern containing all components required for normal classroom operation. The system is built around a Crestron control processor / presentation system and touchpanel for user interaction, with a touch-enabled preview monitor mounted on an articulating arm.

The video sources available are: Podium PC, HDMI, VGA + audio connections for portable devices (via hardwired breakout cables), and document camera. A mini-DisplayPort to HDMI adaptor is fastened to the HDMI cable with steel aircraft cable. The PC is connected via HDMI output, and is installed on its side on front shelf area giving user access to the USB slots.

For voice amplification, there is a flexible gooseneck microphone and two wireless microphone receivers inside the podium, with lockable compartment for accompanying body pack transmitter. Audio amplifier, any additional AV switching, processing, and transmission/distribution hardware are all stored in the podium. The audio output from the amplifier is wired to wall- or ceiling-mounted speakers appropriate for the size of the room.

There is a VoIP phone installed on the podium for classroom support, as well as a reading light.

For full list of FTS components please see **Section 2.1.6** below. For complete description of Standard FTS GUI specification, please see **Section 5.1** below.

## 2.1.1 Full Teaching Station Input Plate

This is a custom 11.5 x 1.75" plate with the following connectors:

- Mic level XLR input,
- Stereo 3.5mm line-level in,
- Stereo 3.5mm line-level out,
- USB ports (2x)

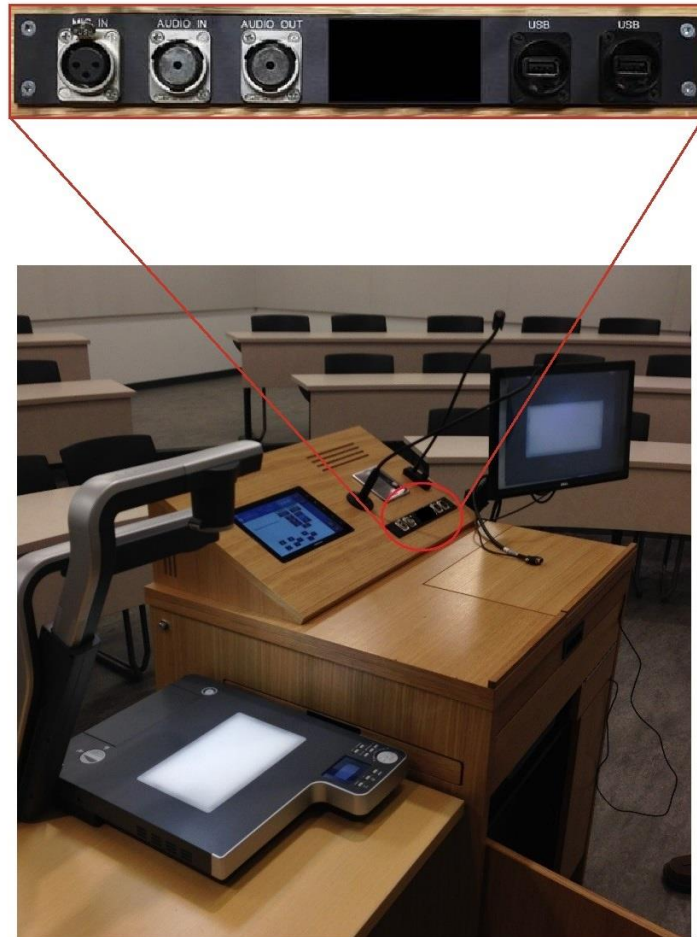

**Fig 2.1.3: Podium Input Plate**

## 2.1.2 Full Teaching Station AV Sources

Video:

- Built-in PC
- Laptop HDMI
- Laptop VGA/Audio
  - Audio input must operate with or without VGA video signal present
- Document Camera

Audio:

- Program audio (from video source)
- Gooseneck Microphone
- Lavalier Microphone
- Second wireless microphone (on request)
- Podium plate XLR input
- Podium plate 3.5mm input

All video sources in system are to appear scaled to their original aspect ratio on the projection screen and preview monitor, never stretched.

## 2.1.3 FTS Podium Interface

- The touchpanel is used for control; there is no video preview.
- Monitor is used for preview content from PC, laptop sources and document camera

Dual-projection allows instructors to show different source material on two projection screens or have the displays mirrored. For clarity, projectors are labelled with large number “1” and “2” decals visible from the podium, so that the instructors know which one will display the intended material.

Whichever source is selected on the touchpanel is displayed on the preview monitor, regardless of what is currently shown on the projector(s).

A schematic drawing of the podium millwork is available separately. If there are any changes to the millwork cutouts as compared to the drawing, UTSC will obtain an up-to-date as-built podium drawing from the millworker and provide these to the installer.

Where dual-projection is implemented, the program audio must work as follows:

- If there is only a source showing on P1, we hear audio from the P1 source
- If there are two sources with audio showing on P1 and P2 respectively, audio should play from the last source sent to either projector. This allows users to toggle between two sources with audio. They simply have to select the source they want to hear, and resend to the desired projector.
- If there is a source showing on P2, and P1 is either OFF or showing DOC CAM, audio should play from the P2 source.

## 2.1.4 FTS Projector Specifications

For large classrooms, projectors must meet or exceed the following specifications. Room brightness must also be considered on a case-by-case basis:

### Minimum Brightness:

25 – 120 seats: 6500 Lumens

120 – 350 seats: 8000 Lumens

350 - 500 seats: 12,500 lumens

Minimum Native Resolution: WUXGA 1920 x 1080

Minimum Contrast Ratio: 8000:1.

## 2.1.5 Room Layout

The dual-projector feature of the Large Classroom Standard is preferred, but can only be implemented in rooms with an applicable layout. All seats must fall into the optimal viewing angle (30°) for both displays. If the front wall is too narrow, a single-projector version of the FTS will be implemented. In these systems, Picture in Picture (PiP) functionality will be implemented to preserve dual display capability. This special case requires some customization of installation, cabling, and podium interface.

The screen height must conform to the AVIXA standard “1/6<sup>th</sup> requirement”, whereby the height of the screen must be no shorter than 1/6<sup>th</sup> of the distance from the screen to the furthest seat in the classroom. Unless specified otherwise, the screen should have an aspect ratio of 16:9. The electric screen must accept low-voltage controlled from a relay in the control processor. Fixed cinema-style screens are also acceptable in installations where it can be installed without obstructing view of the blackboard.

The Large Classroom Standard requires that the audio system be comprised of ceiling mounted speakers configured in an overlap pattern suitable for the seating layout, and that the wattage of said system be powerful enough to satisfy the demands of program audio and voice reinforcement in accordance with the room's size, layout, and composition of building materials.

For large auditorium-type rooms, it is required that an audio and video line-out be installed at the rear of the room, with AC power and Ethernet as well, for videography / live streaming of events. Audio should be in line-level XLR format either as a single feed with master mix of room audio, or separated into two XLR outputs with all microphones mixed on the first, and program audio alone on the second. Video output should be HDMI and mirror what is on Projector 1.

## 2.1.6 List of Main FTS Components

All of the following components are to be supplied and installed by the AV contractor:

- Crestron TSW-1060 Touchpanel (Black)
- Crestron DMPS3-4K-350-C Control Processor / Switcher
- Wolfvision VZ-8light Document Camera
- Epson Pro L1490U laser projector(s)
- Chief RPAA1 security mount, CMS0406 Pipe and CMA110 Ceiling Flange
- DA-Lite motorized projection screens (with low voltage controller) according to room size
- Middle Atlantic CAB-COOL Cooling fans (2)
- Shure gooseneck MX418S/C mic with shock-mount
- ShureSLX4 wireless microphone receivers (2) and one SLX1 bodypack transmitter
- Breakout HDMI and VGA + audio cables
- Plate with 2x USB, XLR and 3.5mm audio inputs, and 3.5mm audio output jack
- Chief K1W120B monitor arm
- Dell 24" Touchscreen LCD monitor
- RCI 3513 Relay-controlled magnetic cabinet lock to secure the wireless mic compartment
- TOA A-724 Amplifier
- Wall or ceiling speakers according to room size
- Listen Technologies LT-800-072 Assisted Listening transmitter for 100+ capacity rooms.
- Middle Atlantic UPS-1000R Uninterruptable Power Supply
- Dell 7070 MT PC
- Cisco Catalyst 2960CX network switch

PC, preview monitor, and PoE switch will be provided by UTSC.

## 2.1.7 FTS AV Schematic

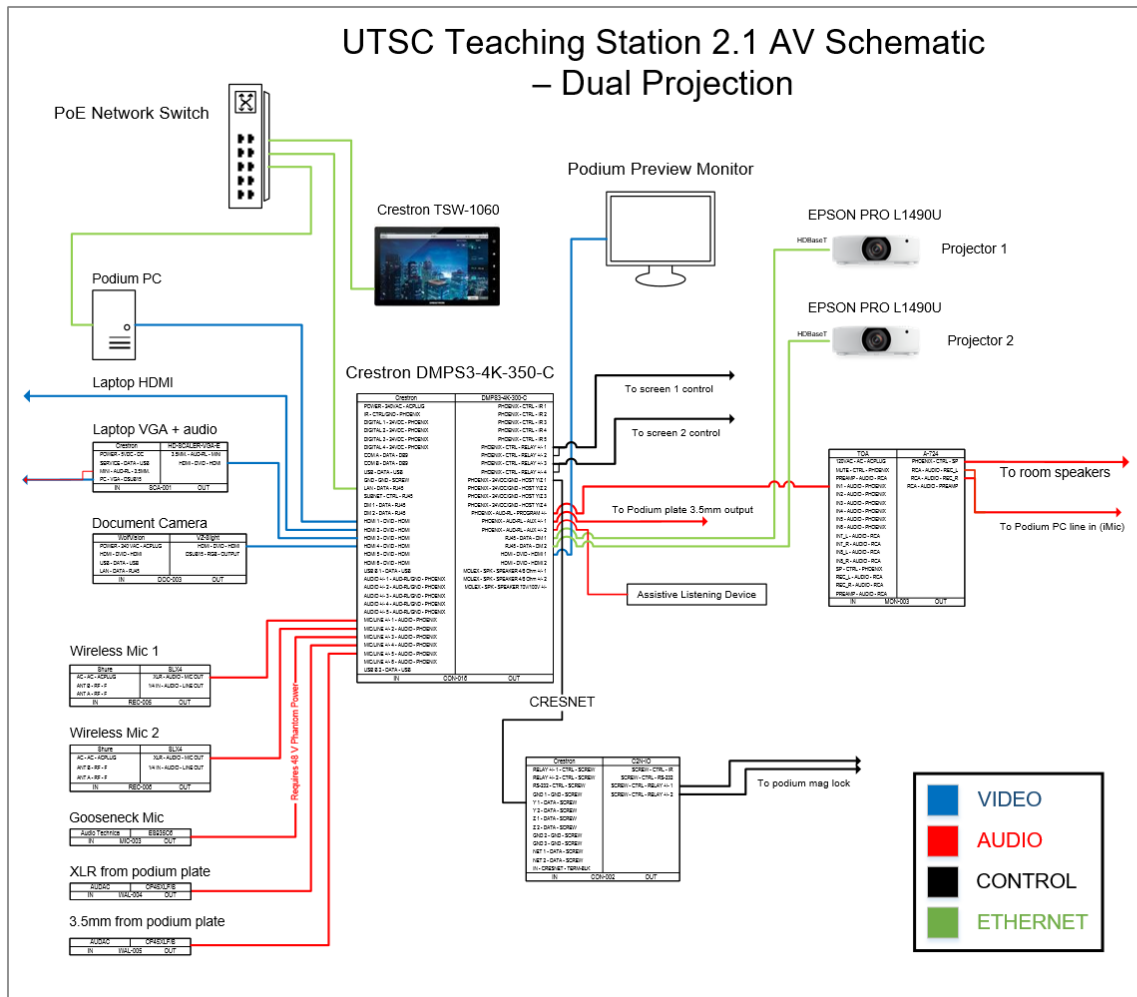

University of Toronto  
Scarborough  
1265 Military Trail  
Toronto, Ontario M1C 1A4  
416-208-2006

Scale: 1/4" = 1'-0"  
Created: 1/15/2017  
Modified: 3/6/2020  
Printed: 8/18/2015

Prepared by:  
Blake Markie CTS-D  
Schematic View

A PDF of this schematic is available upon request.

**Important:** All equipment models listed in this document are current versions. As models are frequently introduced and discontinued, we require full signoff on all equipment lists prior to procurement / installation.

## 2.2 Small Classroom Standard

The Small Classroom Standard comprises the Teaching Station Junior podium - hereafter **TSJr** - in conjunction with a data projector, audio system, and electric screen. In the case of the Small Classroom, the audio system need only be used for program (PC) audio; no microphones are in this standard. However, in the case of some borderline semi-large rooms with abnormal layouts, microphones have been included for voice reinforcement.

The TSJr is a half-height podium, which features a simple Crestron button panel for projector and volume control. The TSJr also includes an all-in-one PC mounted on a flexible arm. The PC is the default video source when the system is powered on.

There is a VoIP phone installed nearby at accessible height for classroom support.



**Fig 2.2.1: Teaching Station Jr.**

The podium will have the following video sources: All-in-One PC, Laptop HDMI, and Laptop VGA + audio. These sources shall be scaled to fill the projection screen without stretching the image. The laptop connections shall be in the form of professional-quality breakout cables. There is a mini-DisplayPort to HDMI adaptor fastened to the HDMI cable with steel aircraft cable.

## 2.2.2 TSJr. Projector Specifications

The Small Classroom Standard requires that the audio system and ceiling or wall-mounted speakers meet the requirements of the seating layout. For rooms of this size, projectors must meet or exceed the following specifications. Room brightness must also be considered on a case by case basis:

### Minimum Brightness:

40 seats or fewer: 5000 Lumens

40 - 150 seats: 6500 Lumens

Minimum Resolution: WUXGA 1920 x 1080

Minimum Contrast Ratio: 8000:1

The motorized screen must meet the 1/6<sup>th</sup> height requirement, fit the 16:9 aspect ratio for all new installations, and must accept low-voltage AC for control from the podium.

More detailed information on the TSJr can be found here:

<http://sites.utoronto.ca/teachingstation/tsj/index.html> However, note that unlike the UTSC version, the TSJr specified at aforementioned URL does not include a built-in PC.

## 2.2.3 List of Main TSJr. Components

All of the following components are to be supplied and installed by the AV contractor

- Crestron MP-B10 Button Panel
- Crestron DMPS3-4K-150-C Processor / Switcher
- Fellowes Designer Suites™ Flat Panel Monitor Arm (Item #8038201)
- Epson PowerLite L615U laser projector
- Chief RPAA1 security mount, CMS0406 Pipe and CMA110 Ceiling Flange
- DA-Lite motorized projection screens (with low voltage controller) according to room size
- Middle Atlantic CAB-COOL Cooling fan
- Breakout HDMI, VGA + audio cables
- Extron XPA 2001 amplifier
- Wall or ceiling speakers according to room size
- APC BE650G1 Uninterruptable Power Supply
- Dell OptiPlex 7470 AIO PC
- Cisco Catalyst 2960CX network switch

PC and PoE switch will be provided by UTSC.

## 2.2.4 TSJr. AV Schematic:

### Teaching Station Jr. AV Schematic

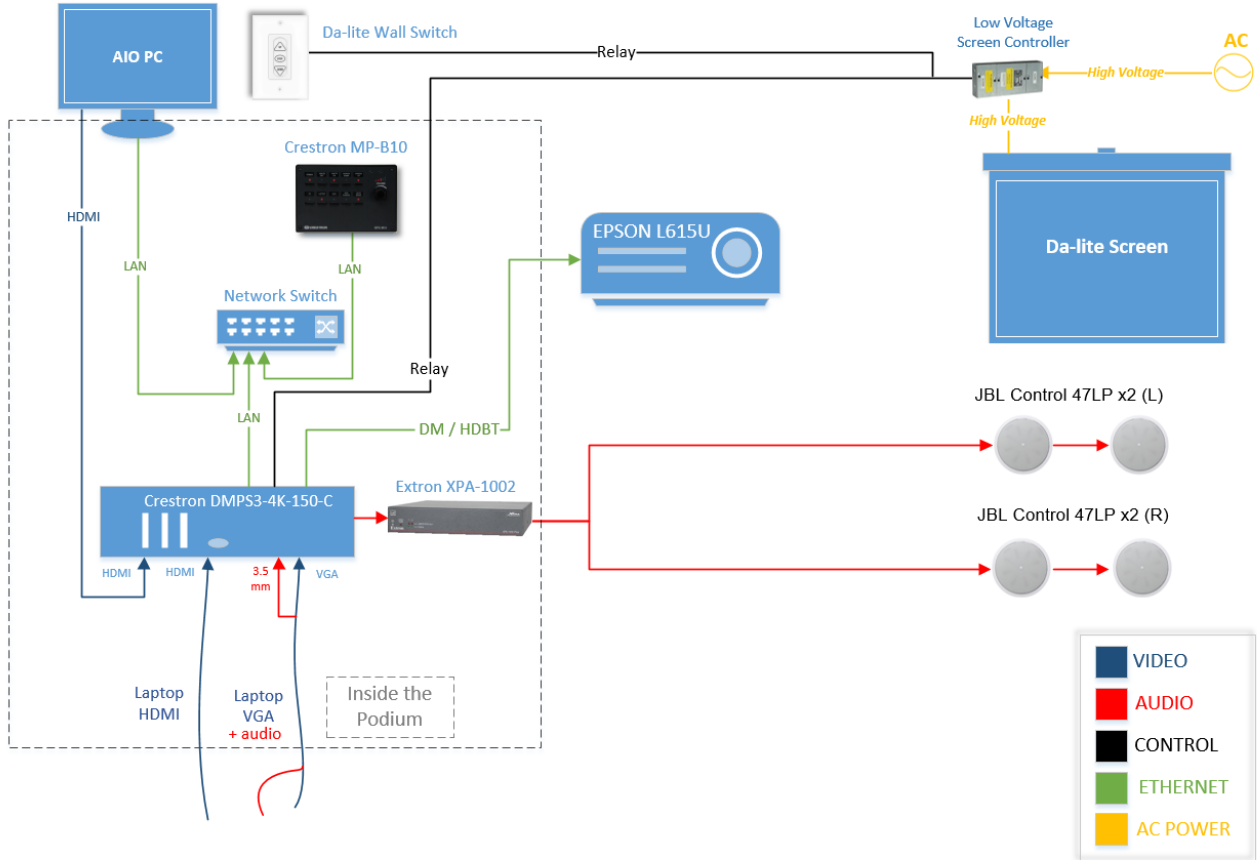

A PDF of this schematic is available upon request.

**Important: All equipment models listed in this document are current versions. As models are frequently introduced and discontinued, we require full signoff on all equipment lists prior to procurement / installation.**

## 2.3 UTSC Large Meeting Room Standard

In large meeting rooms, the space can be used for presentations, meetings, and/or tele/videoconferencing. Therefore, the rooms are equipped with an array of flexible AV equipment. Typically, IITS provides a projector and screen as well as a single wall-mounted LCD display opposite the projector screen. If there is a podium, it will have the standard inputs (HDMI, VGA + audio) as well as a local PC, and there must also be video inputs at the table (one or two table monuments (a.k.a. Cable Cubbies) depending on the table size. These will also have USB connection to the local PC for loading content, and AC power for charging devices. For sound reinforcement, there will be four or more ceiling speakers, which amplify one or more wireless microphones and program audio.

If the room requires conferencing, the table will be equipped with boundary microphones for audio conferencing and the room will have two wall-mounted cameras for videoconferencing. The microphones and cameras should be routed, via AV-bridge device, to the local PC for web-based conference applications (Microsoft Skype for Business, etc.). For best audio performance, the integrator should install a digital signal processor (DSP) with acoustic echo cancellation (AEC) among the podium components. This will eliminate unwanted feedback and echo when using web-conferencing applications.

If there is no podium in the room, there should be a wall-mounted touchpanel for AV control in the presentation area, adjacent to an AV input plate for laptop connection. The table may also have a touchpanel control. To best emulate the controls and inputs of other (classroom) AV systems on campus, the touchpanel should be the Crestron TSW-1060, with GUI similar to that of the Teaching Station (to be approved by UTSC). The input plate should have HDMI and VGA + audio (e.g. Crestron DM-TX-200-C-2G)



*Fig 2.3.1: A large meeting room at UTSC*

**Important: All equipment models listed in this document are current versions. As models are frequently introduced and discontinued, we require full signoff on all equipment lists prior to procurement / installation.**

## 2.4 UTSC Small Meeting Room Standard

In small meeting rooms, IITS provides a single or dual wall-mounted UHD LCD display with built-in PC for simplicity of use. A **Crestron MPC3-102** button panel is installed in the wall near the LCD screen, powered by PoE and connected to the LCD screen via serial cable for control

A **Dell Micro PC** is mounted behind the LCD via HDMI, within easy reach for servicing. The standard mount is the Dell VESA mount for micro PC. The PC should be out of sight, while still removable without dismantling the LCD screen.



On the table sits a wireless keyboard and mouse, and the LCD remote. Also included in this standard is the **Yamaha CS-700** webcam / sound bar / microphone array for use in videoconferencing.

The display – typically 60”, 70” or 80”, must meet the 1/6<sup>th</sup> requirement for screen height.

In the case of larger board- or meeting-rooms, two LCD screens should be wall-mounted on perpendicularly opposed or opposite-facing walls for optimal viewing.

The meeting room standard includes a table monument with AV connectivity through an in-floor conduit to the display screen (HDMI, USB). If a table monument is not possible due to the room layout or structure, then loose HDMI and USB cables must be neatly installed for the connection of external devices.

For greater ease of service, any rack-mountable equipment for a more complex meeting room must be installed inside a rack or credenza, and not behind the LCD screen. Only the micro PC may be installed behind the LCD.



*Fig 2.4.1: A typical UTSC Small Meeting Room*

**Important: All equipment models listed in this document are current versions. As models are frequently introduced and discontinued, we require full signoff on all equipment lists prior to procurement / installation.**

## 2.5 UTSC Huddle Room Standard

The smallest meeting rooms, seating 2-4 people, are referred to as Huddle Rooms. This configuration consists of a single UHD LCD display with built-in PC with webcam (typical model: **Logitech BRIO 4K**) and wireless keyboard and mouse. There is no button controller since the rooms are typically small enough that the users can reach the LCD screen from a seated position to access built-in power, input, and volume controls. A loose HDMI cable is installed for laptop connections.

## 2.6 Active Learning Classrooms

Three emerging standards have been identified for Active Learning Classrooms:

- **Small Active Learning Classroom.** For rooms of 25-59 seats, there will be a Full Teaching Station with single projector and screen, plus one large wall-mounted LCD screen per table, with the ability to present wirelessly (from laptop or mobile device) to the projector or any of the LCDs. The podium touchpanel will be designed so that the instructor can use the system normally (“Classic View”) or use the multi-screen and multi-source features (“Active Learning View”) by switching between clearly labelled tabs on the graphical user interface.



*Fig 2.6.1: Proposed UTSC Small Active Learning Classroom layout*

- **Medium Active Learning Classroom.** For rooms of 60-199 seats, there will be a Full Teaching Station and no fewer than three projectors and screens, each on their own wall. Wireless presentation will allow anyone in the room to present to any of the screens.
- **Large Active Learning Classroom.** For large 200+ seat auditorium –type rooms, there will be a Full Teaching Station and two projectors and screens at the front of the room. Wireless presentation will allow anyone in the room to present to either of the screens.

## 2.7 Non-classroom standards

### 2.7.1 Digital Signage

In addition to the classroom and meeting room standards, UTSC has a standard for digital signage that is found in hallways and foyer-type spaces.

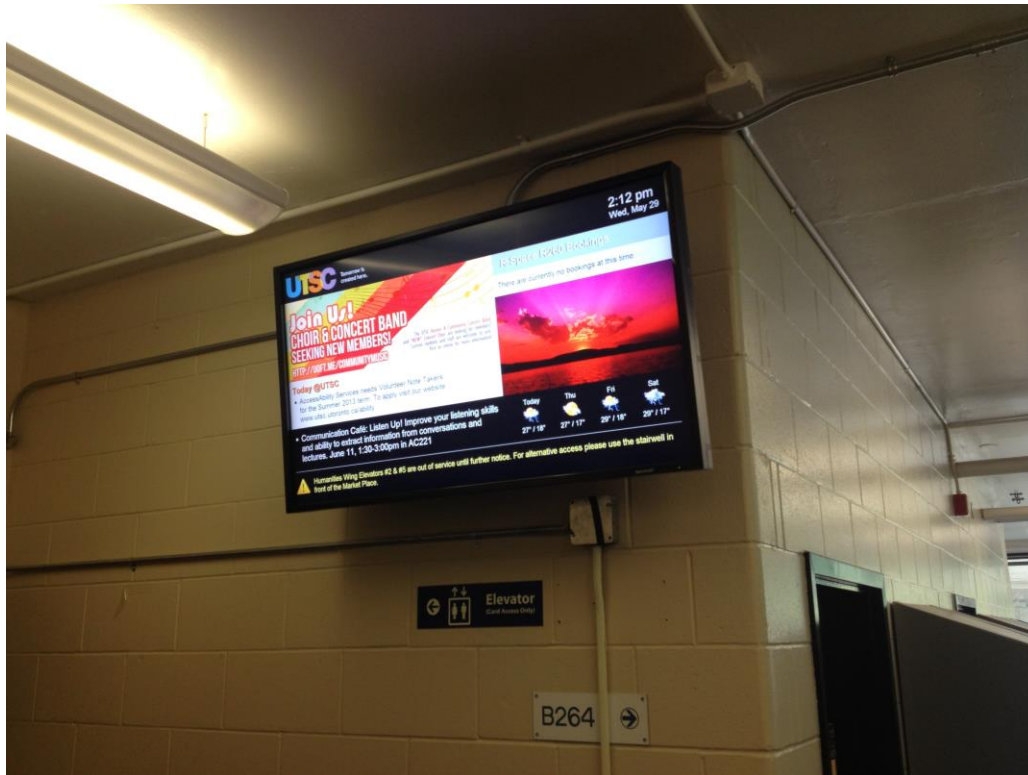

**Fig 2.7.1: UTSC Digital Signage screen**

These installations consist of wall-mounted commercial grade LCD screens with a Dell Micro form factor PC mounted behind the screen connected via HDMI. A single duplex AC and data jack must be installed at location of screen. Content is fed over the network and the PC is administered remotely.

LCD size will be determined – by UTSC / IITS - by the size and layout of the space.

The micro PC must be mounted in a manner similar to the Small Meeting Room standard – in a Mac Cuff or similar PC mount, out of sight but easily accessible for service, i.e. the PC should be removable without dismantling the LCD screen.

**Important: All equipment models listed in this document are current versions. We expect that many will no longer be available at the date of installation. We therefore require full signoff on all AV equipment prior to procurement / installation.**

## 3.0 Installation Requirements

All wiring must be neat and tidy inside the podium, cabinet, or behind wall mounted displays. All cabling must be meticulously labeled using printed labels. Hand printed labels will not be accepted. Cable bundling must be done using removable Velcro ties, and never plastic zip-ties. When possible, especially in the case of the Full Teaching Station, cable management laneways as seen in *fig 3.0.1* are required.

Below please see three examples of installations that followed requirements:

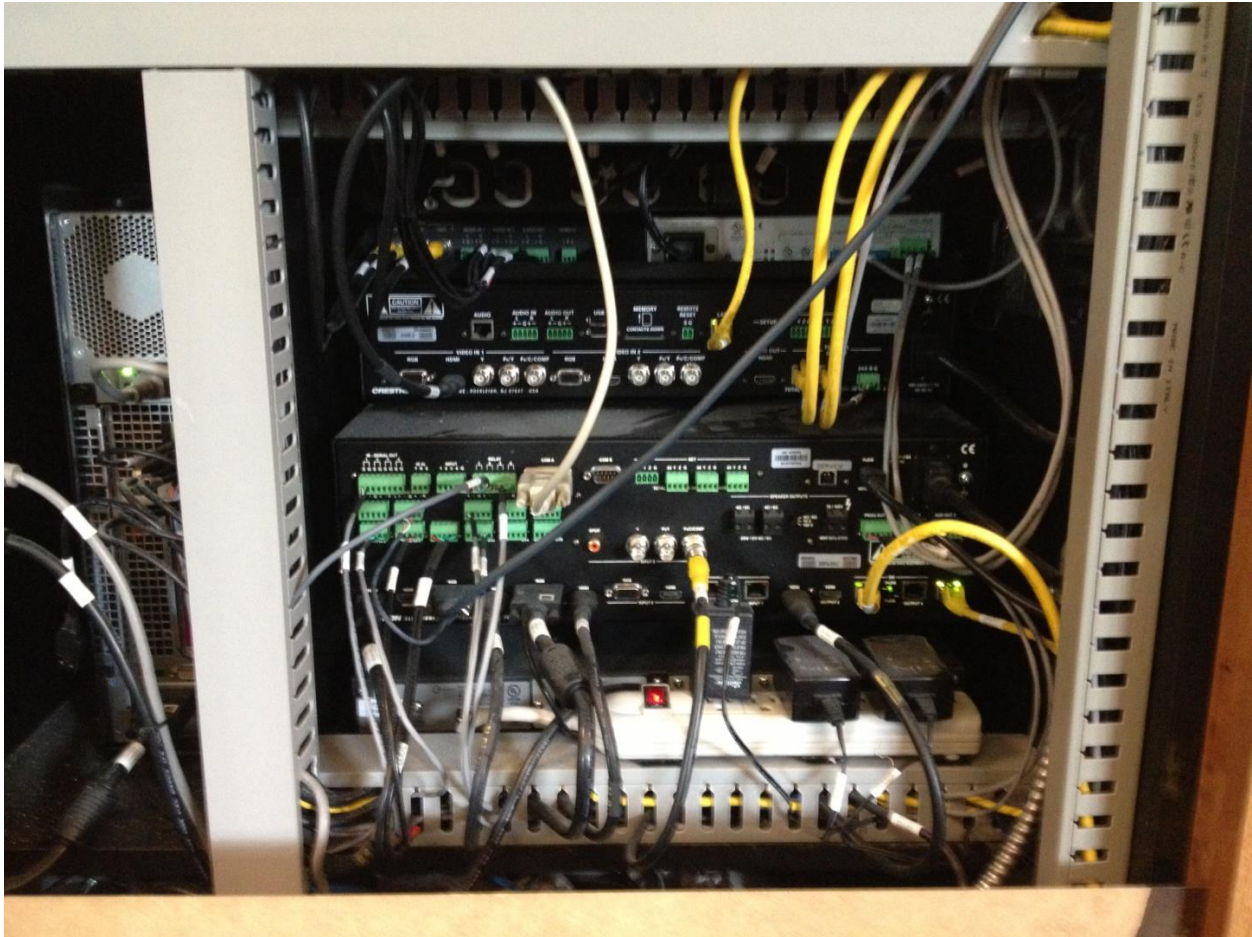

*Fig 3.0.1: Inside the rear compartment of a well installed Full Teaching Station – note the clean integration and cable laneways.*

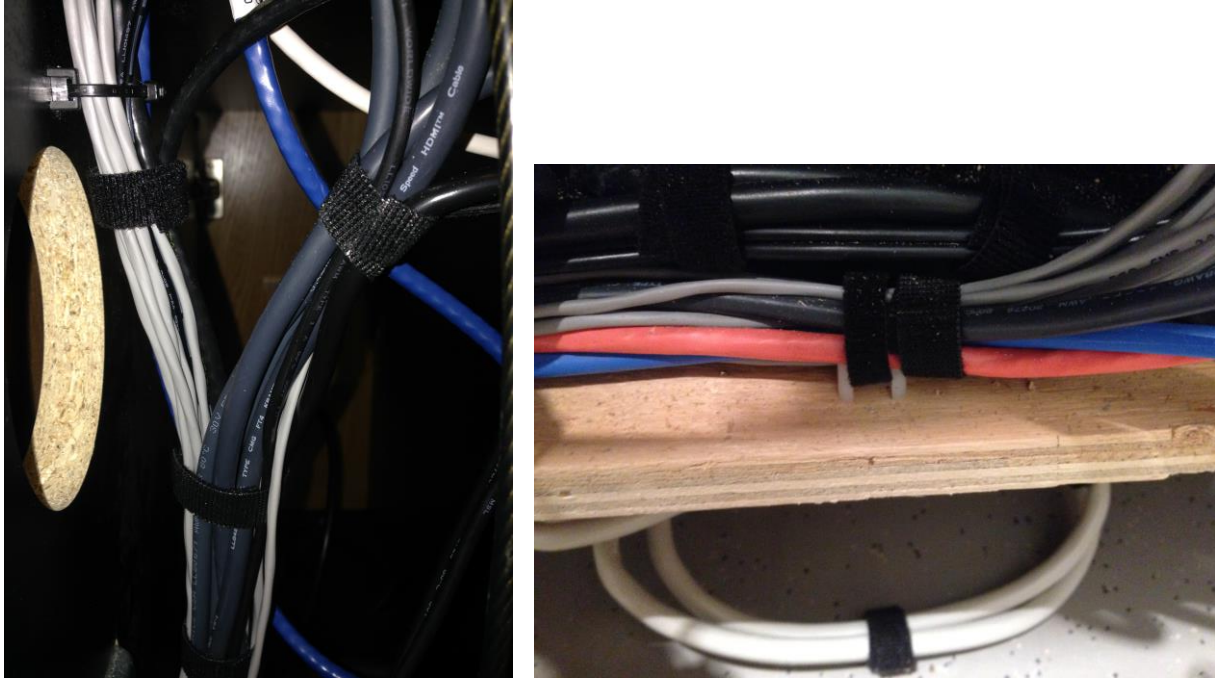

**Fig 3.0.2:** Inside a well installed FTA. Note the Velcro ties.



**Fig 3.0.3:** Inside a well installed TSJr. Note the clear cable labeling, cleanly integrated wire blocks, and Velcro tie for bundling.



**Fig 3.0.3: Top view of a clean TSJr installation – note presence of UPS and Network Switch.**

The AV supplier must provide any surge protection bars and/or UPS's required to power all AV equipment and protect it from power spikes/surges.

Cooling fans must be installed on each side of the podium, to ensure proper operating temperature of the equipment. For optimal cooling, and to prevent dust from entering the millwork, fans should blow *outwards*. For TSJr podiums, the fan should be on the opposite side of the seating area.

Termination of AC and Data inside podium will be performed by electrician. This includes the installation of AC outlets in one-gang millwork cutouts on outside of podium for users to charge devices.

Low voltage cabling, i.e. CAT6 run from podium to projector, speaker wires, relay wiring for screen control and magnetic lock can be performed by AV integrator.



***Fig 3.0.4: AC and data termination inside TSJr.***

Safe installation practices must be followed at every step. Load-rated screws and bolts must be used for hanging installations, with a safety factor of 5 taken into consideration. Company safety records will be reviewed prior to installation projects.

All technical drawings shall be provided including cable and equipment labeling as per installation.

## 4.0 Product Compatibility Requirements

The custom millwork for the podiums used in FTS and TSJr standards are made exclusively by third party company. The locks on these podiums must be keyed to conform to those used at UTSC.

All control system hardware must be Crestron brand, in accordance with the current University of Toronto standards.

All projectors must be NEC brand and include Chief RPAA1 Projector Mount unless requested otherwise.

Wireless microphones for FTS are Shure brand.

Podium PCs for FTS must be current Dell Optiplex Small Form Factor model with HDMI connection to AV system.

The TSJr uses a Dell Optiplex All-in-One PC with HDMI connection to AV system.

Computers installed in meeting rooms must at minimum meet these specifications:

Dell OptiPlex Micro

Intel® Core™ i5-8500T Processor (Quad Core, 9MB, 4T, up to 3.5GHz, 35W)

RAM – 8GB 2X4GB DDR4 2666MHz Non-ECC

Harddrive – M.2 256GB SATA Class 20 Solid State Drive

HDMI output.

Include Dell KM636 Wireless Keyboard and Mouse Combo

Include Micro VESA Mount with Adapter Box, D9

### **All PCs in new AV system installations will be provided by UTSC**

All FTS and TSJr podiums are outfitted with UTSC-provided Cisco Catalyst 2960C Switch 8 FE PoE brand managed POE network switches. Other networking equipment must not be used without explicit approval from IITS.

LCD screens for meeting rooms must be of professional grade and of a make and model approved by UTSC. Chief-brand mounting hardware must be used for mounting.

For Digital Signage, the screen must be a commercial-grade Sharp 47" (or higher) LCD. The PC used is Dell Micro PC series.

# 5.0 Programming and Interface

## 5.1 FTS GUI Specification

This section describes in detail the desired functionality of the UTSC Full Teaching Station touchpanel GUI, down to the page, sub-page and individual button. The goal is to capture every parameter controlled by the touchpanel so that integrators will program new systems exactly as desired with a minimum of uncertainty.

SIMPL and VTPro-e code including all pages will be made available to the integrator. Button feedback logic and coloring is programmed into VTP file.

### 5.1.1 Welcome page



Note: "HW214" is an example of room number. Control code will read room number from hostname of Crestron Processor.

<b>Action:</b>	Press anywhere
<b>Result:</b>	Advances the touchpanel to the Home page.

## 5.1.2 Home page

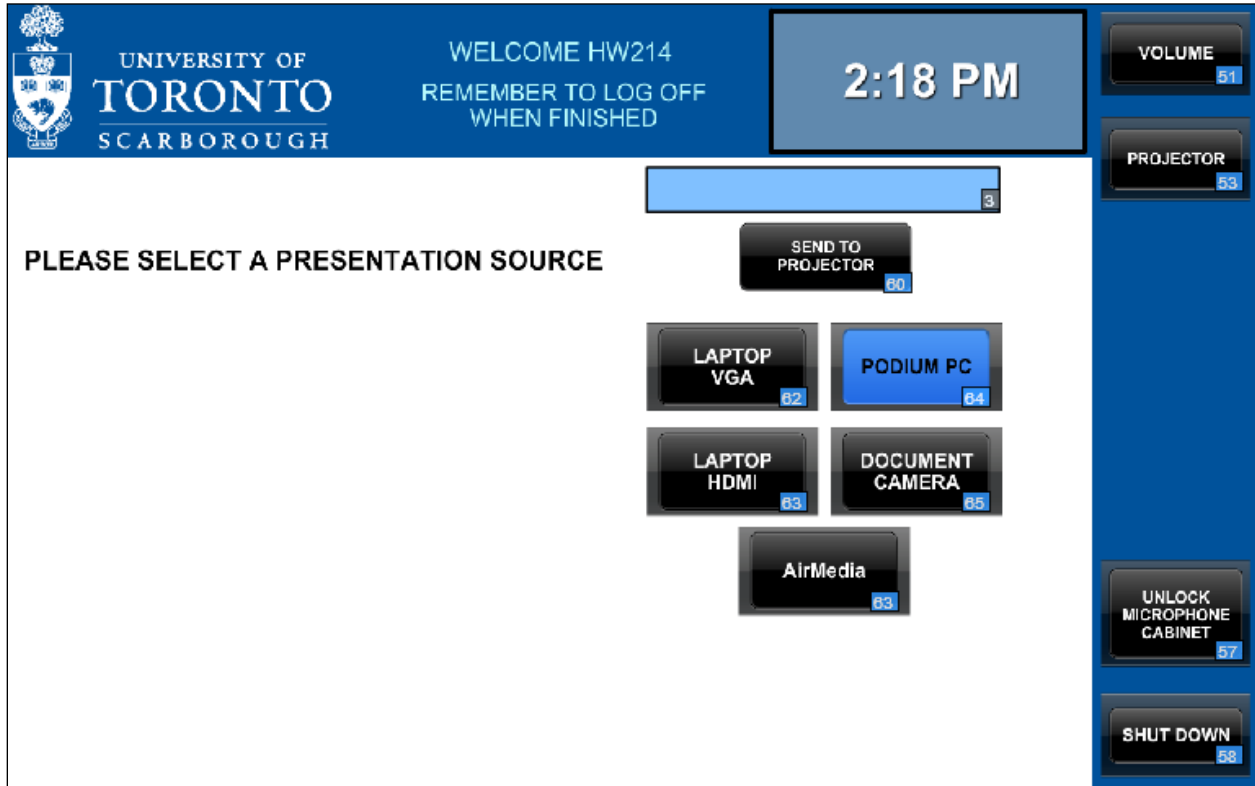

This is the main page of the system, where the user can select their video source, control volume levels and the projector.

Upon reaching the Home page, Roomview attribute “System Power” is set to True. All audio levels are unmuted and set to default initialize levels (80%)

<b>Action</b>	Press any of the Source buttons ( <b>LAPTOP VGA</b> , <b>PODIUM PC</b> , <b>LAPTOP HDMI</b> , <b>DOCUMENT CAMERA</b> , and <b>AirMedia</b> ).
<b>Result:</b>	The selected source will appear on the podium preview monitor.
<b>Note:</b>	The <b>PODIUM PC</b> button should be selected by default when the user reaches the Home page, and the podium PC image should therefore appear on the preview monitor without anything having to be pressed.

<b>Action:</b>	Press <b>UNLOCK MICROPHONE CABINET</b>
<b>Result:</b>	Magnetic lock which keeps microphone cabinet shut unlocks for 5 seconds, then re-locks itself. Feedback for this button is <u>momentary</u> .
<b>Action:</b>	Press <b>SEND TO PROJECTOR</b>
<b>Result:</b>	- The projector is powered on if not already on

	<ul style="list-style-type: none"> <li>- The electric projection screen lowers, if not already lowered</li> <li>- The selected source displays on the projector</li> <li>- Name of source selected / displayed appears in blue text box above <b>SEND TO PROJECTOR</b> button.</li> <li>- Roomview attribute "Proj1 Power" is set to True</li> <li>- Roomview attribute "Proj1 Source" displays source selected (e.g. "Laptop HDMI")</li> <li>- While projector is warming up, Projector Warming page appears until complete:</li> </ul>
--	--



- Once warmup sequence is complete, the touchpanel returns to Home page.

<b>Action:</b>	Press <b>LAPTOP VGA</b> or <b>LAPTOP HDMI</b> button on Home page
<b>Result:</b>	"Laptop Note" appears to left of source buttons. These are instructions for laptop users. Text can be seen in the following two screenshots and is also programmed into .vtp file.

<b>Action:</b>	Press <b>AirMedia</b> button on Home page
<b>Result:</b>	"AirMedia Note" appears to left of source buttons. These are instructions for laptop users. Text reads "Follow the instructions in the <a href="#">preview monitor to connect your mobile device</a> "

### 5.1.2.1 Home page with Volume subpage.

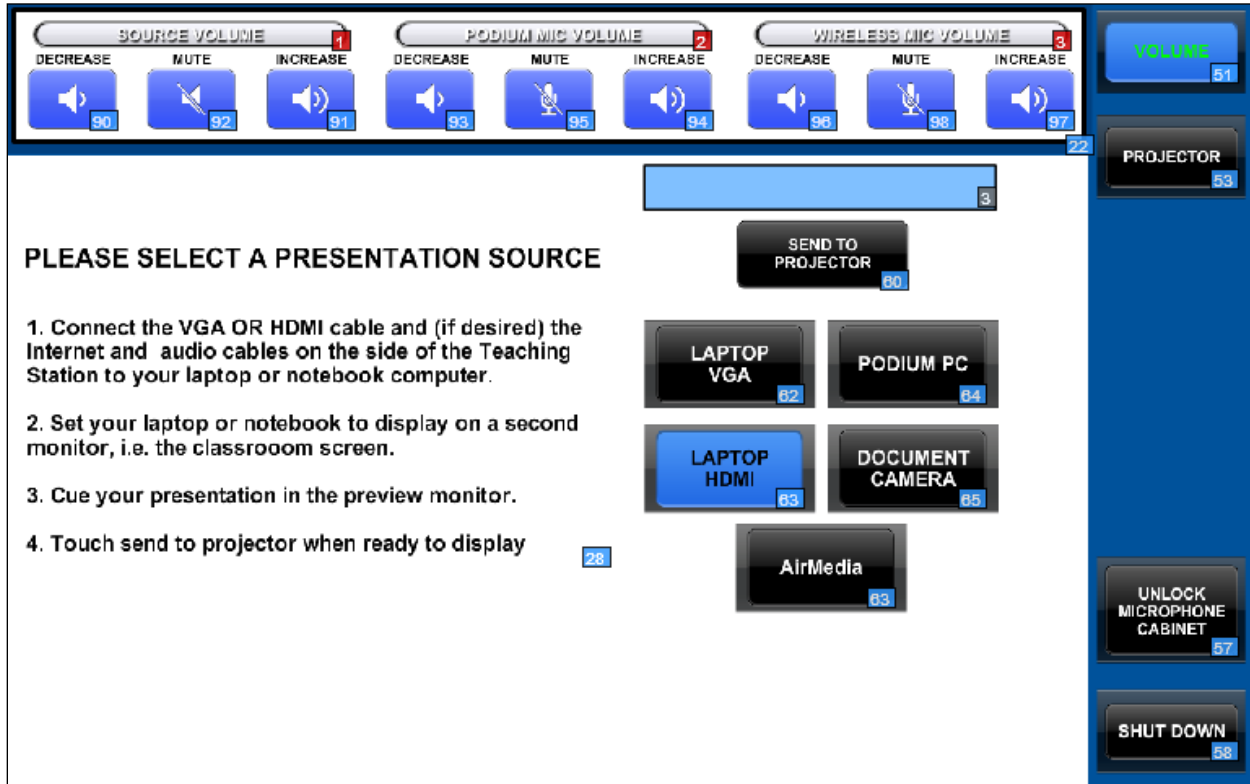

<b>Action:</b>	Press <b>VOLUME</b> button on Home page
<b>Result:</b>	Volume subpage appears.

<b>Action:</b>	Press <b>VOLUME</b> button while Volume subpage is displayed.
<b>Result:</b>	Volume Subpage disappears.

**Note:**

**SOURCE VOLUME** controls the audio level of the video source currently displayed on projector, as well as that of the 3.5mm audio input on plate.

- Roomview attribute "Volume Level" refers to **SOURCE VOLUME** level on touchpanel.
- Roomview attribute "Volume Mute" refers to **SOURCE VOLUME** mute state on touchpanel.

**PODIUM MIC VOLUME** controls level of both the gooseneck microphone and XLR audio input on plate.

- Roomview attribute "Pod Mic Vol" refers to **PODIUM MIC VOLUME** level on touchpanel.

**WIRELESS MIC VOLUME** controls level of both wireless microphone receivers.

### 5.1.2.2 Admin Volume Control page (hidden)

We would like a hidden admin page where technicians can fine tune the six discrete audio levels. This should be accessed by touching and holding **VOLUME** button (in the upper right corner of the screen) for 5 seconds, after which a keypad should appear superimposed on home page:

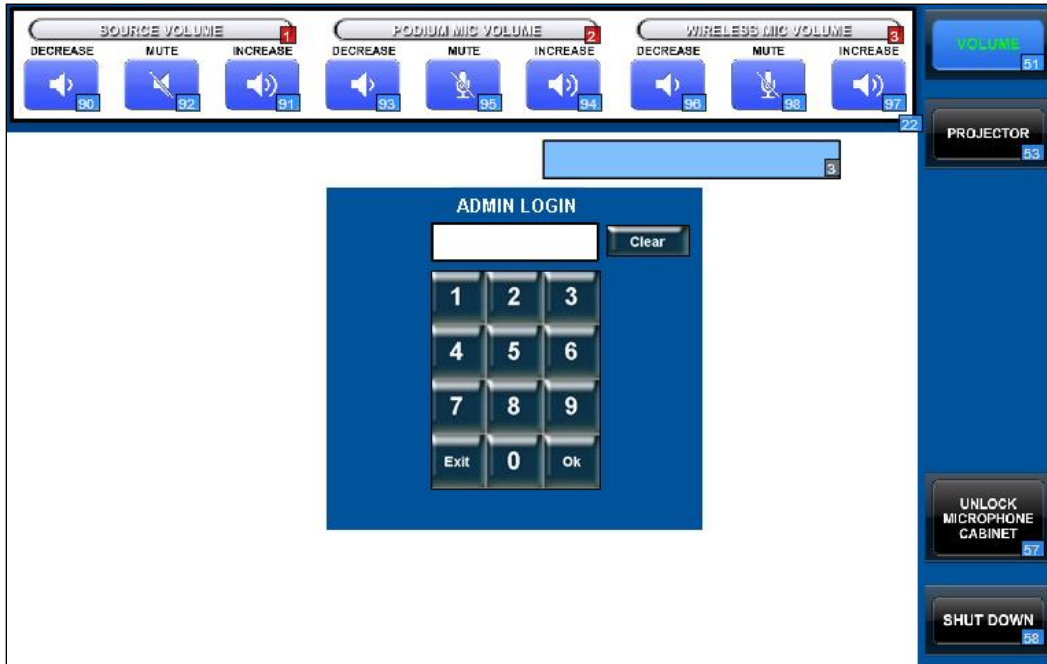

Note: this keypad / login subpage is not programmed into the supplied VPro file.

After successfully entering the 4-digit code, the touchpanel advances to this volume control page:

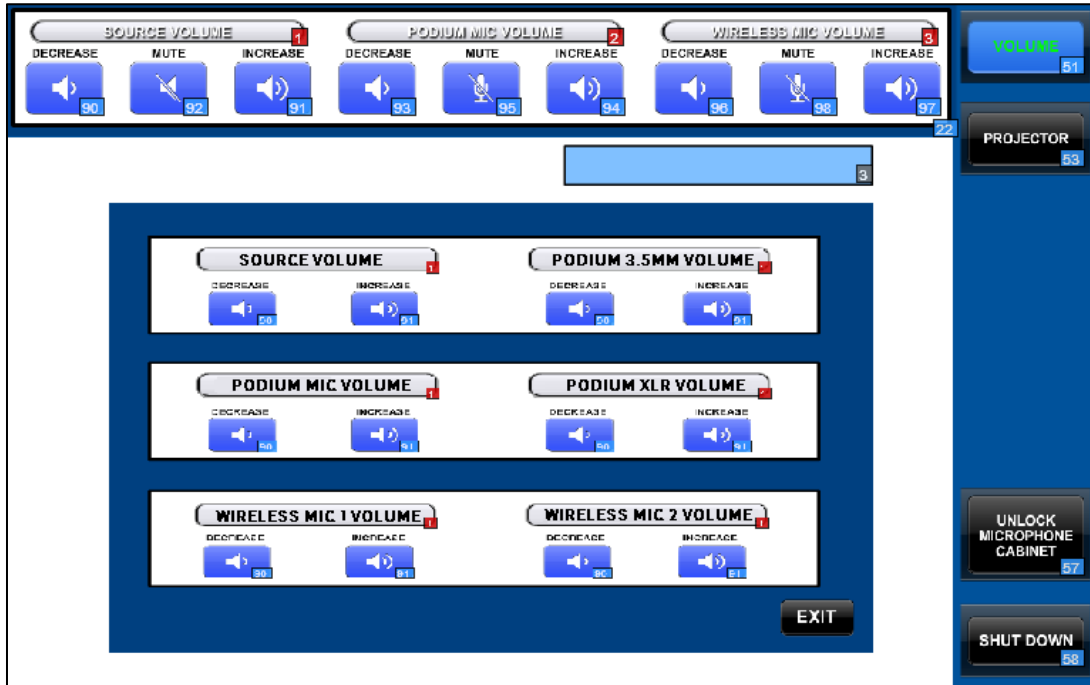

Each row corresponds to one of the faders on the Volume subpage. For example, since Source Volume and Podium 3.5mm Volume are both controlled by the same Source Volume fader on the Volume subpage up top, this is where a technician / admin may make an adjustment between the two levels. Once adjusted, the two levels will still be controlled by the fader on the Volume subpage but with a difference in their respective levels. The volume faders should all be at 100% by default. It is only possible to lower the discrete volumes from this page. Pressing the EXIT button makes the Admin Volume control disappear and returns the touchpanel to the HOME page.

### 5.1.2.3 Home page with Projector subpage

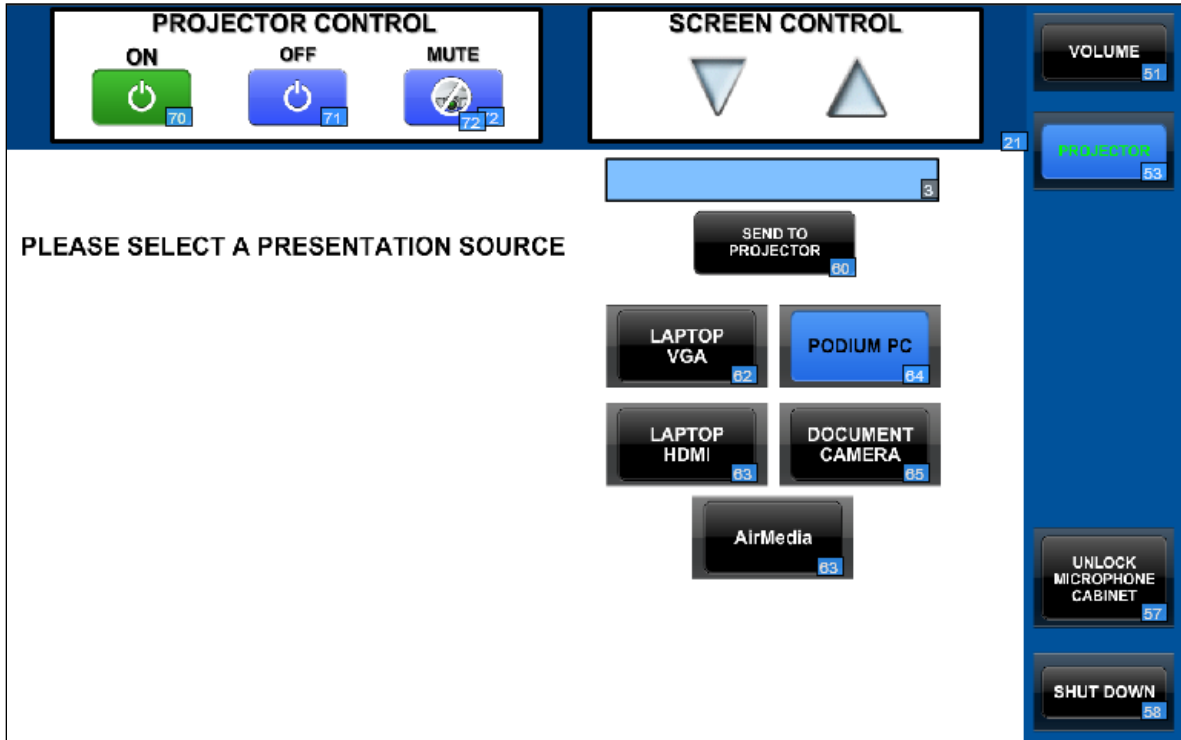

<b>Action:</b>	Press <b>PROJECTOR</b> button on Home page
<b>Result:</b>	Projector subpage appears

<b>Action:</b>	Press <b>PROJECTOR</b> button while Projector subpage is displayed.
<b>Result:</b>	Projector Subpage disappears.

Likewise,

<b>Action:</b>	Press <b>PROJECTOR</b> button while Volume subpage is displayed.
<b>Result:</b>	Projector Subpage appears.

And vice-versa.

### 5.1.2.4 Shutdown page



<b>Action:</b>	Press <b>SHUT DOWN</b> button on Home page.
<b>Result:</b>	Shutdown page appears.

<b>Action:</b>	Press <b>CANCEL</b> (Red X)
<b>Result:</b>	Returns touchpanel to Home page.

<b>Action:</b>	Press <b>SHUT DOWN</b> (Green checkmark)
<b>Result:</b>	<p>System shuts down:</p> <ul style="list-style-type: none"> <li>- Projector powers down</li> <li>- Projection screen goes up</li> <li>- Preview monitor shows black</li> <li>- All audio system is muted</li> <li>- Roomview attribute "System Power" is set to False.</li> <li>- Touchpanel advances to Projector Cooling page</li> </ul>

### 5.1.2.5 Projector Cooling page

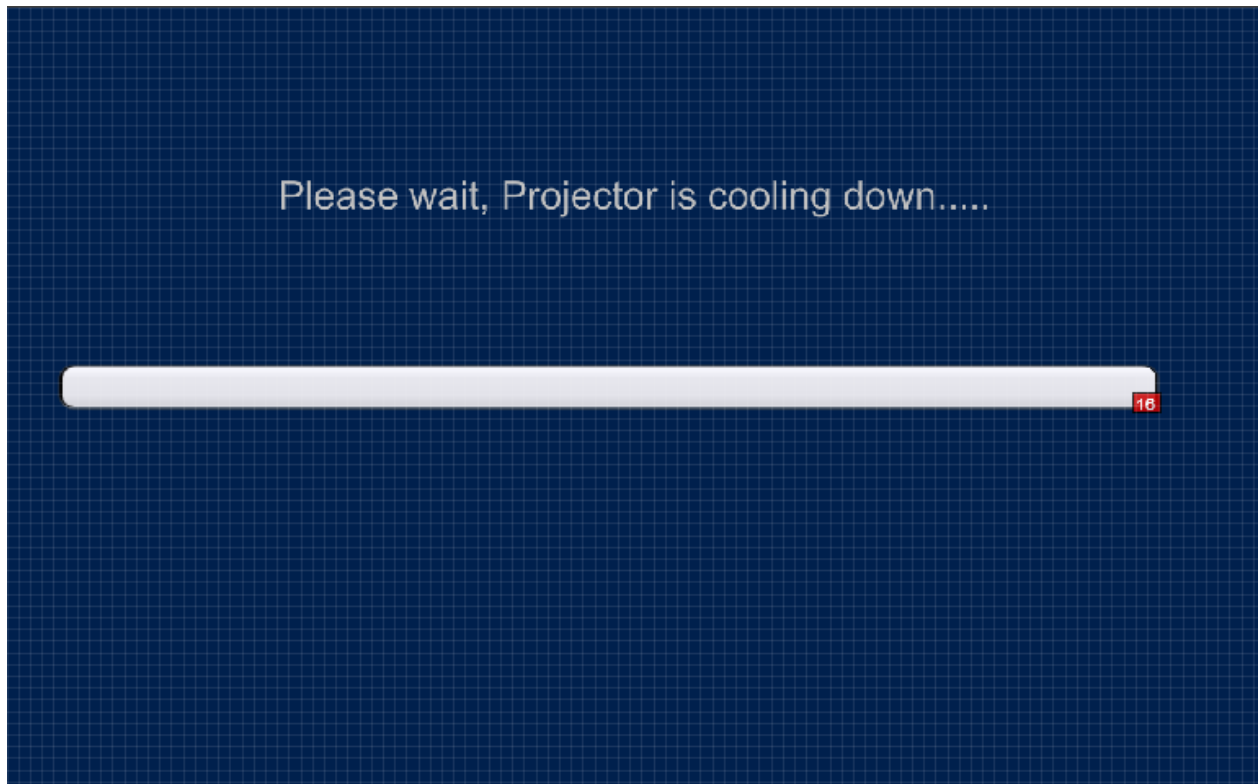

**Action:** None.

**Result:** Once projector cooling is complete, the touchpanel returns to Welcome page.

## 5.2 Standard GUI for TSJr.

The button layout for TSJr. is standardized in the following layout:



*Fig 5.0.3 – The TSJr. button panel layout*