

ONE WAY SLAB DETAILS 1

FOUNDATION & WALL DETAILS 2

STRUCTURAL STEEL AND OPEN WEB STEEL JOIST DETAILS 3

LINTEL DETAILS 4

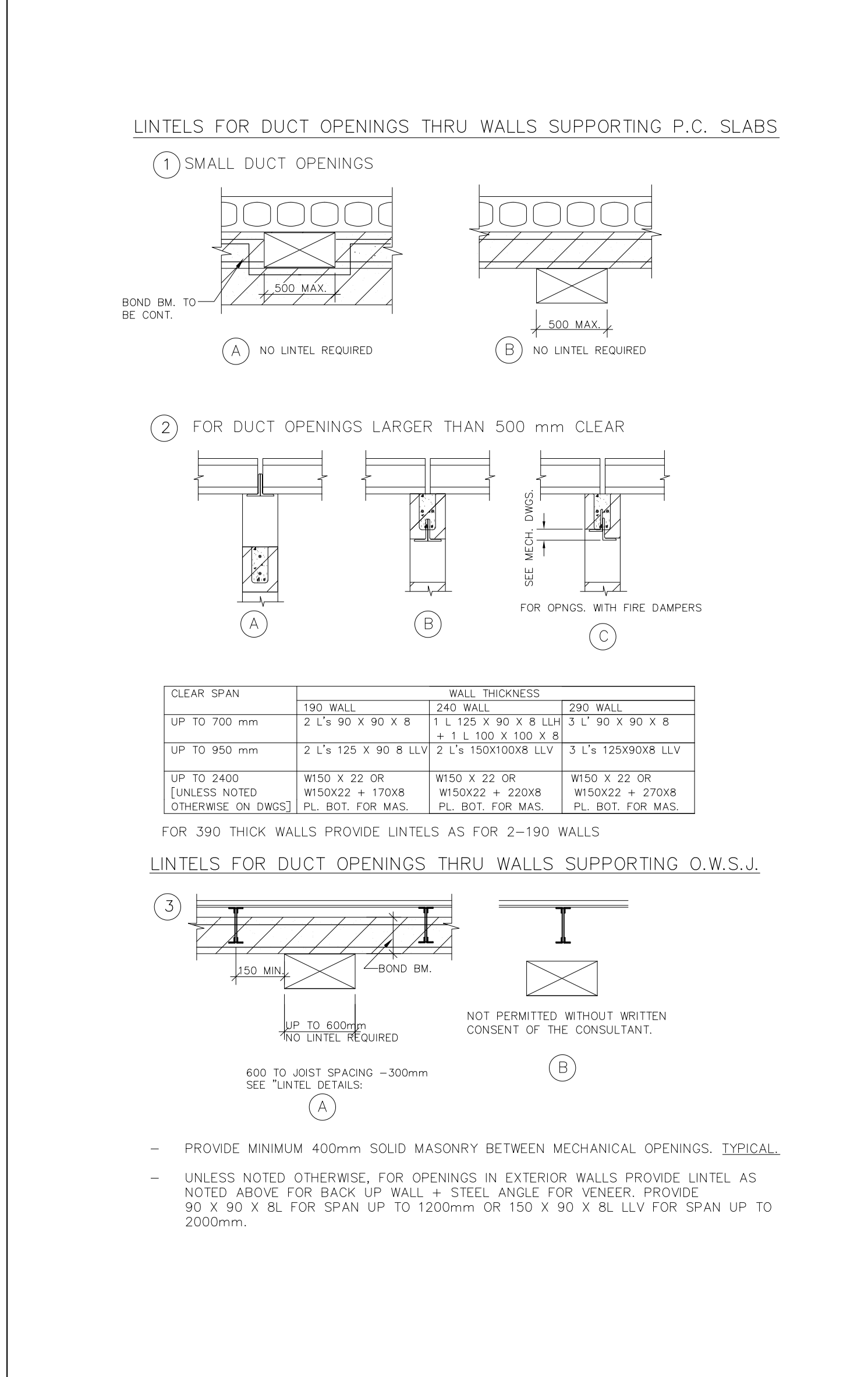
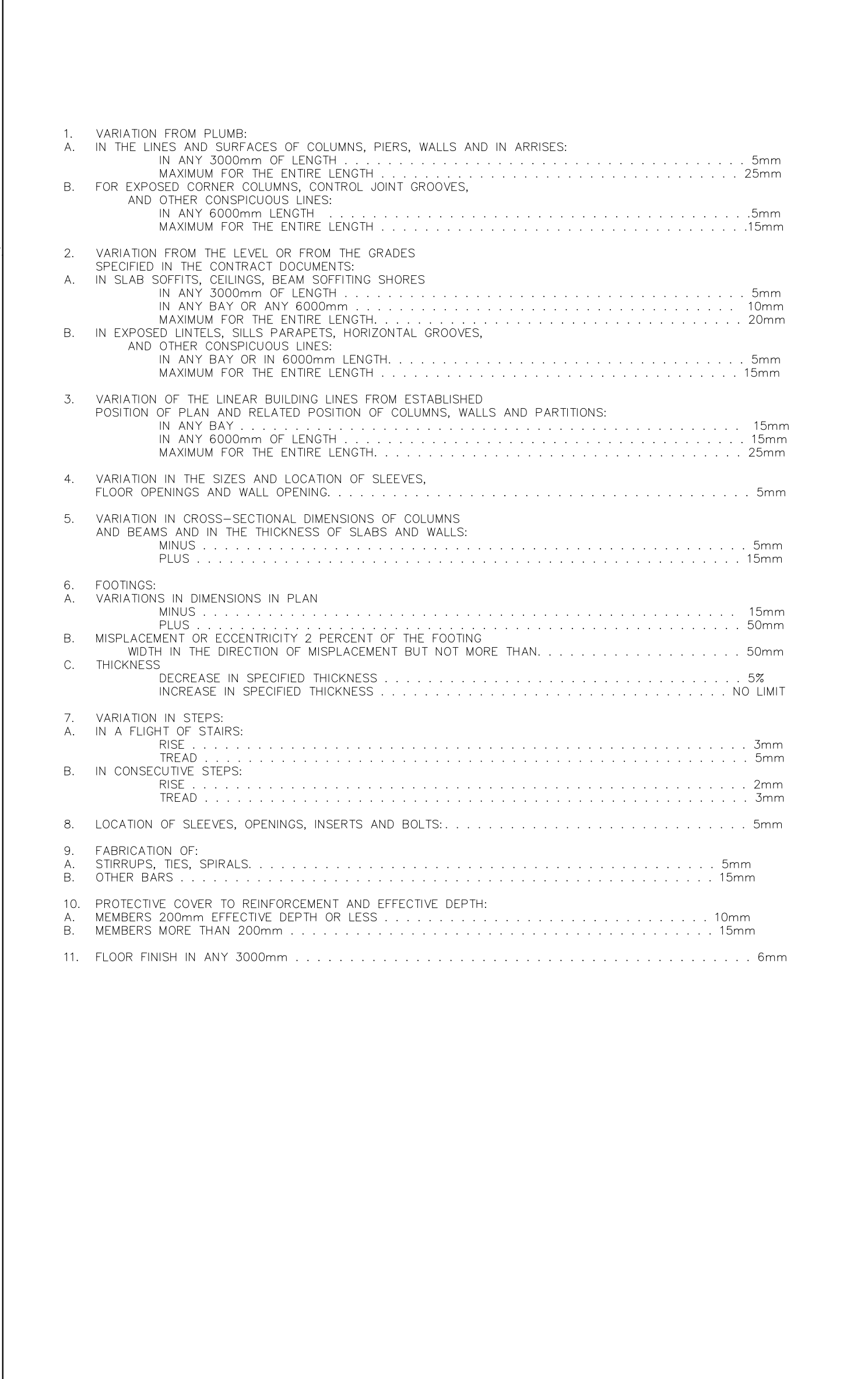
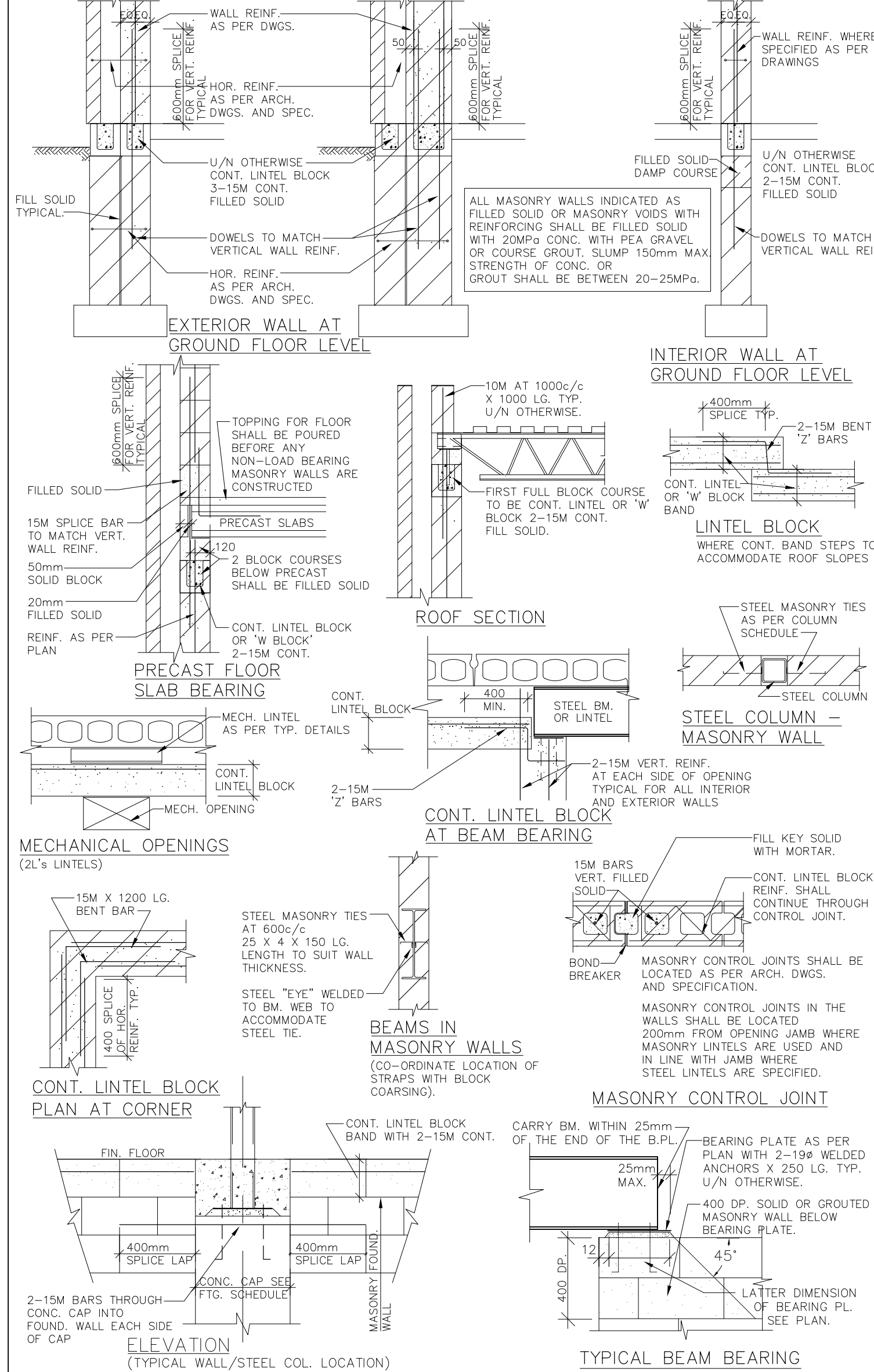

CHECK ALL DIMENSIONS SHOWN ON THE STRUCTURAL DRAWINGS AND REPORT DISCREPANCIES TO THE ARCHITECT BEFORE PROCEEDING WITH THE WORK.

FOR LOCATION OF SUMPS, PITS, BASES AND DEPRESSIONS REFER TO ARCHITECTURAL, MECHANICAL AND ELECTRICAL DRAWINGS.

DO NOT EXCEED THE DESIGN LIVE LOADS SHOWN DURING CONSTRUCTION.

THIS STRUCTURE HAS BEEN DESIGNED TO COMPLY WITH O.B.C. 2024.

THE GENERAL CONTRACTOR SHALL EXAMINE EXISTING SITE CONDITIONS AND REPORT ANY INCONSISTENCIES TO THE ARCHITECT BEFORE STARTING ANY WORK.

REFER TO ARCHITECTURAL DRAWINGS FOR STEPPING OF WALL FOOTINGS.

FOUNDATION NOTES:

FOOTING EXCAVATIONS SHALL BE INSPECTED BY A SOILS ENGINEER BEFORE CONCRETE IS PLACED.

FOOTINGS EXPOSED TO FREEZING SHALL BE PLACED AT LEAST 1200mm BELOW FINISHED GRADE.

PROTECT FOOTINGS EXPOSED TO FROST ACTION DURING CONSTRUCTION BY 1200mm OF SOIL OR ITS EQUIVALENT.

THE LINE OF SLOPE BETWEEN ADJACENT FOOTINGS, EXCAVATIONS OR ALONG STEPPED FOOTINGS SHALL NOT EXCEED A RISE OF 7 IN A RUN OF 10. MAXIMUM STEP 600mm.

WHERE A FOUNDATION WALL RETAINS SOIL ON EACH FACE BACKFILL ON BOTH SIDES SIMULTANEOUSLY.

PROVIDE FOOTINGS FOR PARTITIONS THICKER THAN 150mm.

REFER TO THE SOIL REPORT FOR SOIL CONDITIONS AND BEARING PRESSURES.

STRUCTURAL STEEL NOTES:

CENTRE BEARING PLATES UNDER BEAMS OR AS NOTED. BEARING PLATE DIMENSION GIVEN LAST INDICATES SIDE PARALLEL TO BEAM WEB.

STRUCTURAL STEEL SHALL BE GRADE G40.21M 350W HOLLOW STRUCTURAL SECTIONS WHICH SHALL BE G40.21M 350W CLASS C.

CONCRETE NOTES:

THE ULTIMATE 28 DAY STRENGTH OF CONCRETE SHALL BE 25MPa. REINFORCING STEEL SHALL BE DEFORMED BARS OF 400MPa YIELD STRENGTH.

MASONRY NOTES:

PROVIDE MINIMUM 200mm OF BEARING FOR STEEL OR CONCRETE BEAMS SUPPORTED ON MASONRY. REFER TO DRAWINGS FOR SIZES OF BEARING PLATES. BEARING SHALL BE OF SOLID BLOCK OR BLOCK FILLED SOLID WITH 20MPa CONCRETE 400mm DEEP AND PROJECTING 200mm EACH SIDE OF BEAM BEARING PLATE, BASE PLATE OR CONCRETE PAD. REFER ALSO TO TYPICAL DETAIL SHEET 4M.

PROVIDE 200mm DEPTH OF SOLID MASONRY UNDER STEEL JOISTS BEARING ON MASONRY.

BUILD MASONRY TIGHT INTO WEBS OF BEAMS AT THEIR BEARINGS.

PROVIDE ALL TEMPORARY BRACING REQUIRED TO HOLD ALL WALLS PLUMB AND TRUE TO LINE DURING CONSTRUCTION UNTIL THE BUILDING IS COMPLETED.

ALL LOAD BEARING MASONRY WALLS SHALL BE "ENGINEERED MASONRY" IN COMPLIANCE WITH CAN/CSA S304.1.

ALL BLOCK VOIDS WITH REINFORCING BARS SHALL BE FILLED SOLID WITH 20MPa OR COURSE GROUT.

PROVIDE MINIMUM TWO SOLID OR FILLED SOLID WITH 20MPa CONCRETE, BLOCK COURSES FOR ALL PRECAST SLABS SUPPORTED ON MASONRY.

ALL MASONRY PARTITIONS SHALL BE CONSTRUCTED ON TOP OF CONCRETE TOPPING OF PRECAST FLOORS SLABS.

PRECAST CONCRETE SLABS:

PRECAST CONCRETE SLABS SHALL BE DESIGNED IN COMPLIANCE WITH ALL APPLICABLE CODES AND SHOP DRAWINGS SHALL BE STAMPED BY A PROFESSIONAL ENGINEER LICENSED IN ONTARIO.

THE PRECAST SLAB SUPPLIER SHALL REVIEW THE TENDER DOCUMENTS AND CARRY IN HIS TENDER COSTS FOR ANY ADDITIONAL MATERIAL REQUIRED TO ACCOMMODATE PRECAST BEARING BUT NOT INDICATED ON THE STRUCTURAL DRAWINGS.

MASONRY DETAILS 5

CONSTRUCTION TOLERANCES 6

LINTELS FOR DUCTS AND SERVICES 7

GENERAL NOTES

VX
VX ENGINEERING INC.
STRUCTURAL ENGINEERS

VX ENGINEERING Inc.
2500 - 135Marlee Avenue
Toronto, Ontario M6B 4C6
416 870 9422 www.vxengineering.com

PROFESSIONAL ENGINEER
March 27, 2026
V.X.O.X.A.
100062276
PROVINCE OF ONTARIO

no.	revision	date
1	Issued for Coordination	Mar 13, 2026
2	Issued for Permit & Tender	Mar 27, 2026

project
TRILLIUM JUNIOR PUBLIC SCHOOL INTERIOR RENOVATIONS
WATERLOO REGION DISTRICT SCHOOL BOARD

29 W Laurentian Dr., Kitchener, ON N2E 1C3

drawing no.
war999 architects inc.

NTS
war99 project number
25022 - WRDSB TRILLIUM PS
2607 - TRILLIUM PS

project
war999 architects inc.

project
war999 architects inc.

project
war999 architects inc.